



Connecting Certified Manufacturing with Local Solutions

# Fire Pump System Integrator



## SBS SERIES AXIALLY SPLIT CASING DOUBLE SUCTION PUMP

SHANGHAI XUANDUN ZHICUANG TECHNOLOGY  
CO.,LTD.

Address: BUILDING 10, NO. 199, CHANGJIAN ROAD,  
BAOSHANDISTRICT, SHANGHAI,CHINA

Line:@xuanfirebkk

E-mail: Natthanan.udo@xuanfirebkk.com

Website: xuanfirebkk.com



MAKE THE WATER ENDLESS

We keep the products updating. The parameters in the catalog are for reference. We have the rights to edit and change the data.



# CONTENTS



01   Company Profile	06   Types of Installation
03   Product Description	06   Flushing Pipe Arrangement
03   Applications	06   Direction of Rotation and Flow
03   Materials	07   Construction Features of SBS Series with Discharge Flange $\leq$ DN350
03   Operating Range	09   Construction Features of SBS Series with Discharge Flange $\geq$ DN400
03   Technology Application	11   Construction Features of SBSL Series
03   Model Code Designation	13   Curves, Data and Dimensions
04   Selection Charts	
05   Selection Charts	



 <p>高新技术企业</p>	 <p>专精特新型企业</p>	 <p>中国节能产品认证</p>	 <p>创新型中小企业证书</p>
 <p>ISO 14001 环境管理体系认证</p>	 <p>ISO 45001 职业健康安全管理体系认证</p>	 <p>ISO 9001 质量管理体系认证</p>	 <p>安全生产 标准化企业</p>
 <p>合同信用等级 AAA认定</p>	 <p>全国质量检验 稳定合格产品</p>	 <p>上海市 守合同重信用企业</p>	 <p>中国通用机械 工业委员会会员证书</p>

## ■ Company Profile

Strategic Manufacturing Partner of X-FIRE  
 Shanghai Shenbao Industrial Pump Co., Ltd., located in Shanghai, China, is a professional manufacturer specializing in the design and production of industrial pump systems and firefighting equipment. The factory covers an area of over 45,000 square meters and serves industries including petroleum, chemical engineering, HVAC, water treatment, construction, electric power, and firefighting systems.

Shenbao is a strategic manufacturing partner of X-FIRE, providing advanced production capability, engineering support, and internationally compliant products for the global market. All products are designed in accordance with international standards and are manufactured under strict quality control systems including ISO9001, ISO14001 and other industry certifications. The company's products are exported worldwide, including the USA, Germany, Denmark, Spain, Singapore, Thailand, Vietnam, South Africa and other countries.

Through this strategic cooperation, X-FIRE integrates Chinese manufacturing strength with localized market service in Thailand, ensuring certified and compliant products, competitive factory-direct pricing, local technical support and after-sales service, and fast delivery within Thailand.

Quality is the foundation of our cooperation. With Shenbao's manufacturing expertise and X-FIRE's market execution capability, we are committed to providing reliable firefighting solutions for Southeast Asia and global partners. We sincerely welcome distributors, project contractors and industry partners to cooperate with X-FIRE for long-term development.

**Product Description**

SBS series horizontal and SBSL series vertical axially split casing double suction centrifugal pump is a patented product(No. ZL 01 2 39077.1) developed in combination with the characteristics of the similar products in Chinese pump industry. The pumps' performance has been tested and qualified by the China National Industrial Pump Quality Supervision and Testing Center. The technical indicators are in the leading position in China and reaching the advanced level of similar products in the world. The whole series are high in efficiency, good in reliability, and convenient in installation and maintenance.

**Applications**

For clean water or medium with physical and chemical properties similar to clean water. Water supply for water plants, urban drainage, agricultural irrigation, water circulation for power plant, water supply and drainage for industrial and mining enterprises, water circulation for HVAC, water supply for the shipbuilding industry.

For corrosive medium: Seawater desalination, demineralized water in steel mills, brine transportation.

For hot water with temperature below 130°C. District heating supply and water circulations

**Materials**

Casing: cast iron, ductile iron, nickel cast iron, cast steel, stainless steel, duplex stainless steel, etc;

Impeller and sealing ring: cast iron, ductile iron, cast steel, stainless steel, bronze, duplex stainless steel, etc;

Shaft: carbon steel, stainless steel, duplex stainless steel, etc;

Shaft sleeve: stainless steel, duplex stainless steel, etc;

Different material combinations can allow different working conditions;

Special materials can be customized according to requirements.

**Model code designation**

Example: SBS (SBSL) 800-970 E (F)

SBS (SBSL) 800-970 E (F)

SBS – SBS series horizontal split casing pump

SBSL – SBSL series vertical split casing pump

800 – Nominal discharge nozzle diameter (mm)

970 – Nominal impeller diameter (mm) E

(F) - code of impeller hydraulic model

**Technology Application**

High efficiency, high strength, high reliability, long service life.

The optimized hydraulic design based on CFD technology can automatically balance the axial force and radial force to ensure the high efficiency.

Compact structure, reinforced volute casing and high quality components ensure the high stability and reliability of pump.

**Operating range**

Max. capacity: 11160 m³/h

Max. head: 200m

Max. working pressure: 2.5MPa

Max. Suction flange size: DN900 mm

Max. working temperature: 130°C

Flange pressure rate: PN1.6MPa, PN2.5MPa

**Selection Charts**

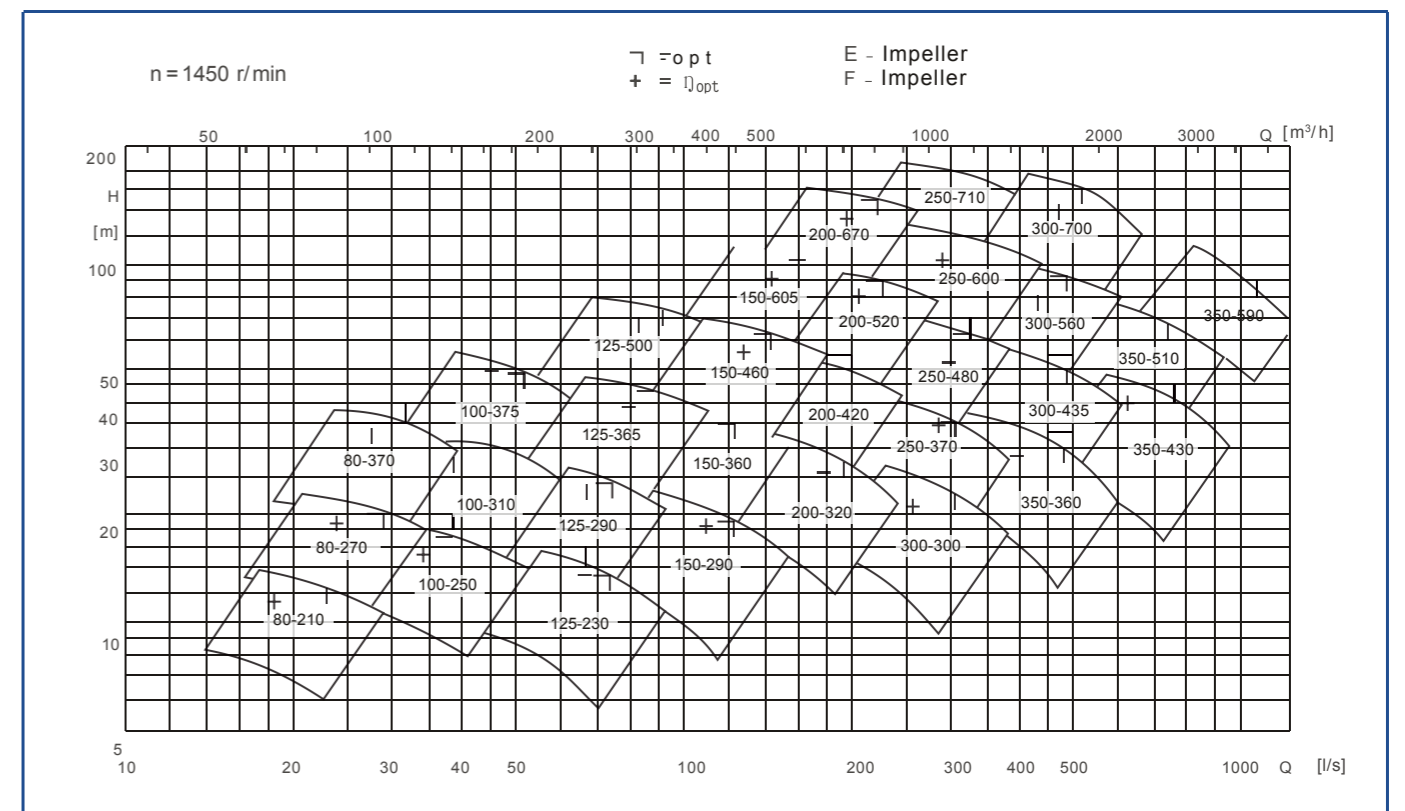
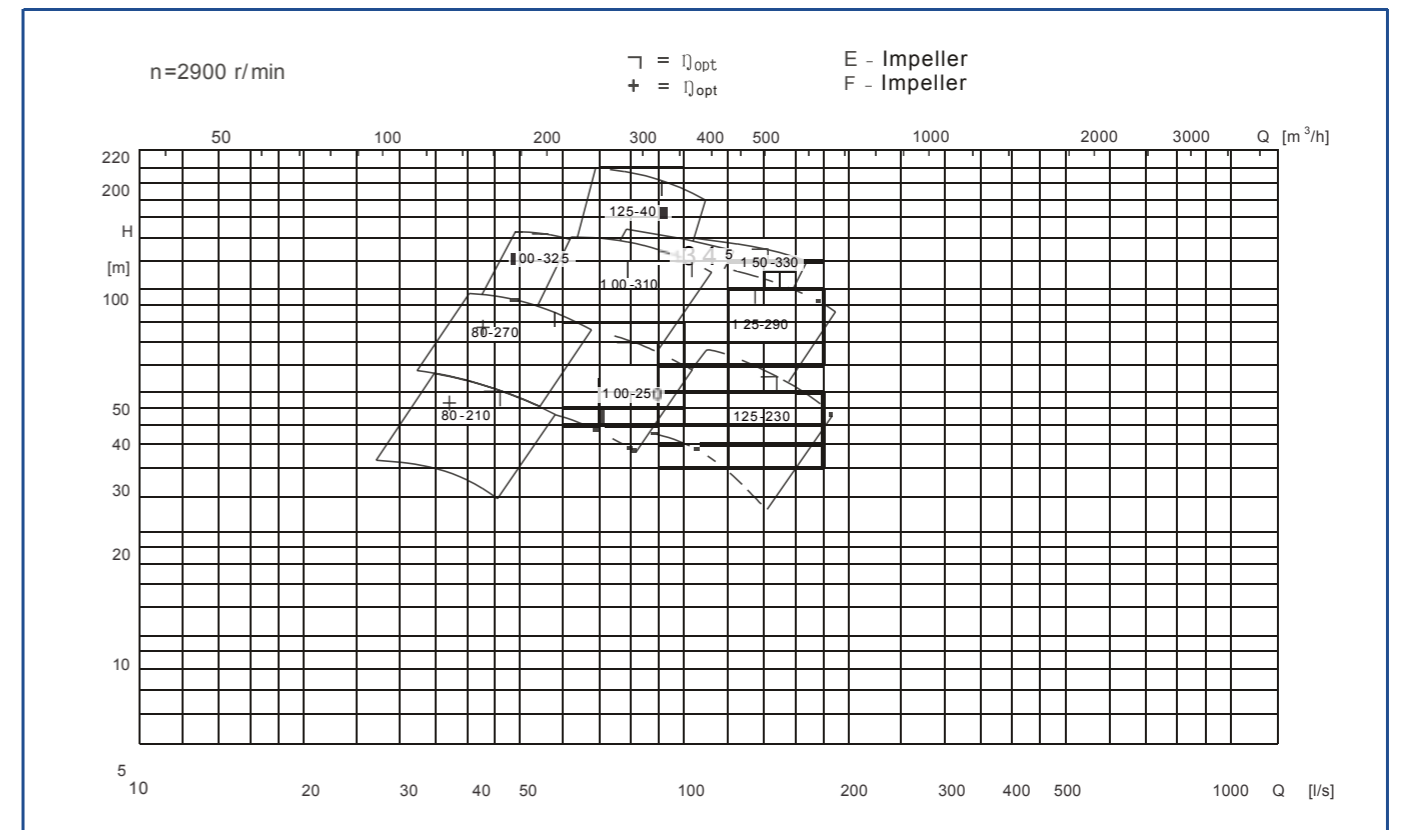

Note: Products beyond the above range can be designed and supplied by orders.

**Selection Charts**

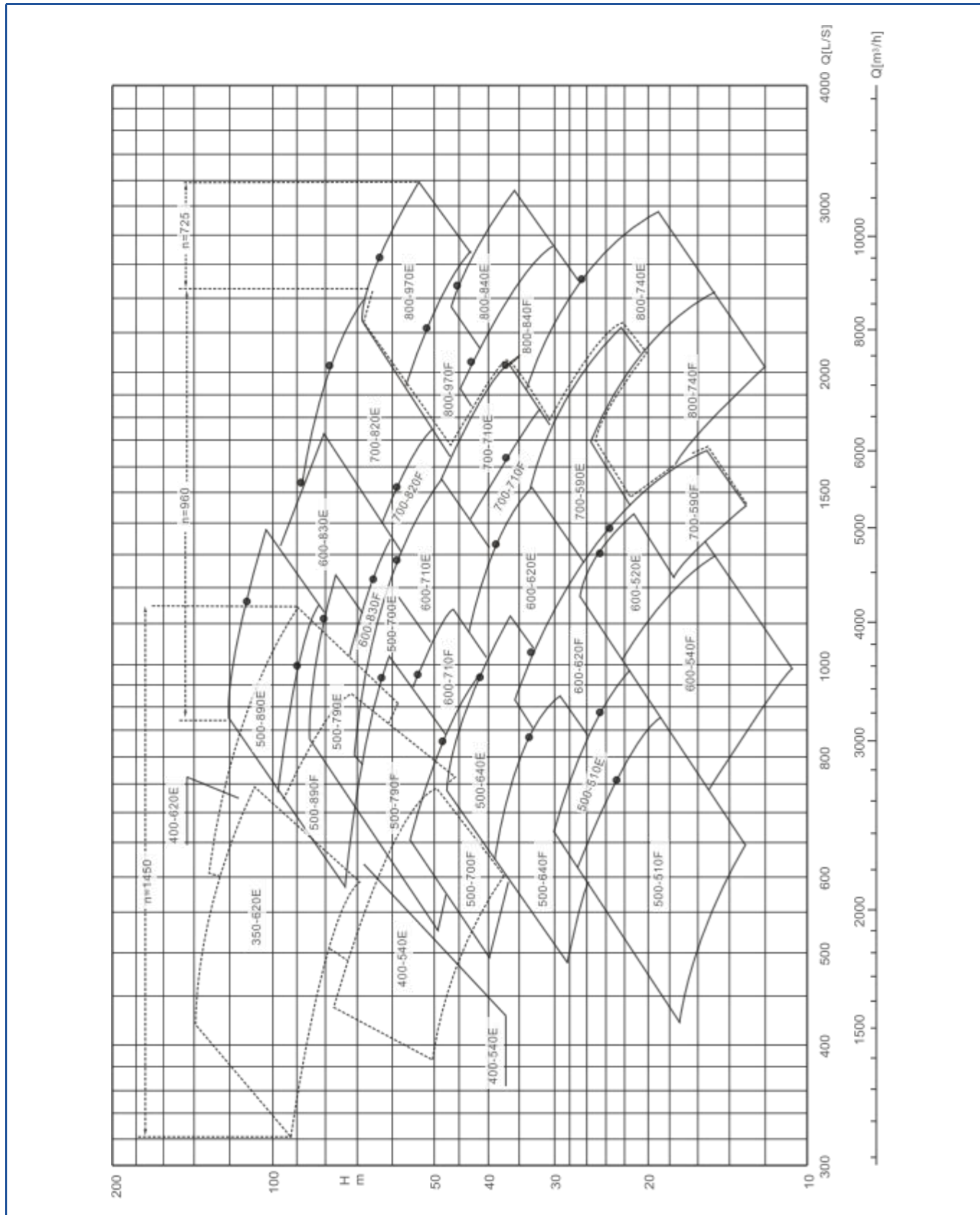

Note: Products beyond the above range can be designed and supplied by orders.

**Types of Installation**

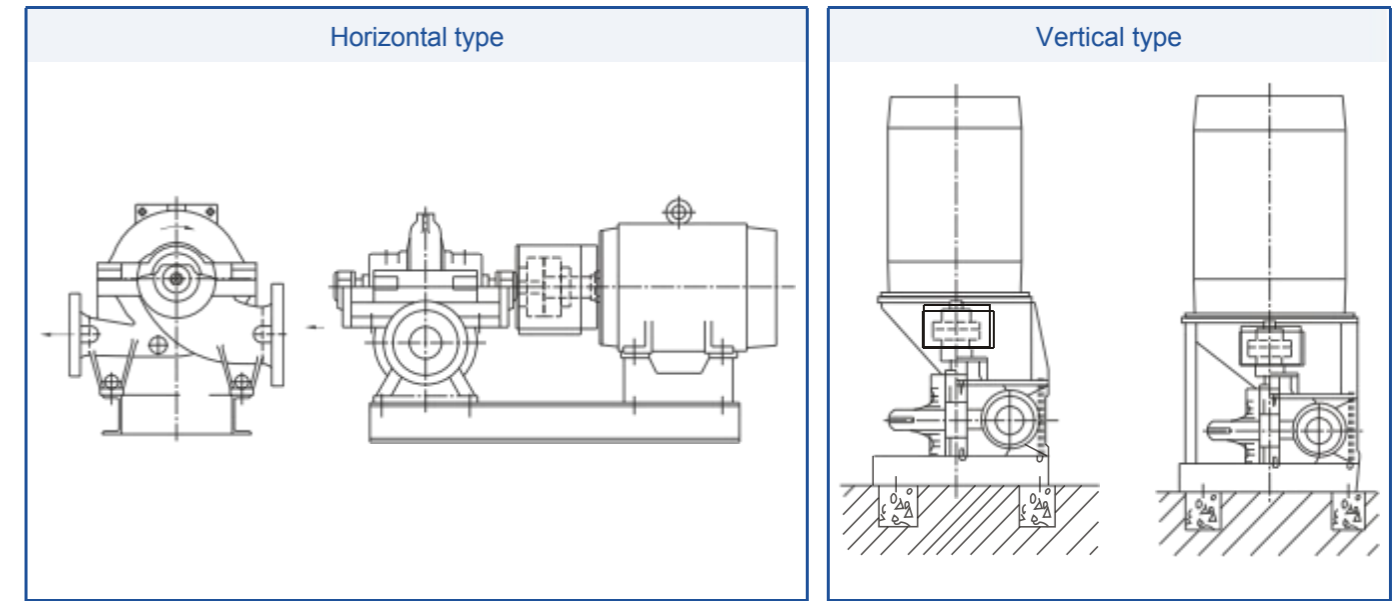

**Flushing Pipe Arrangement**

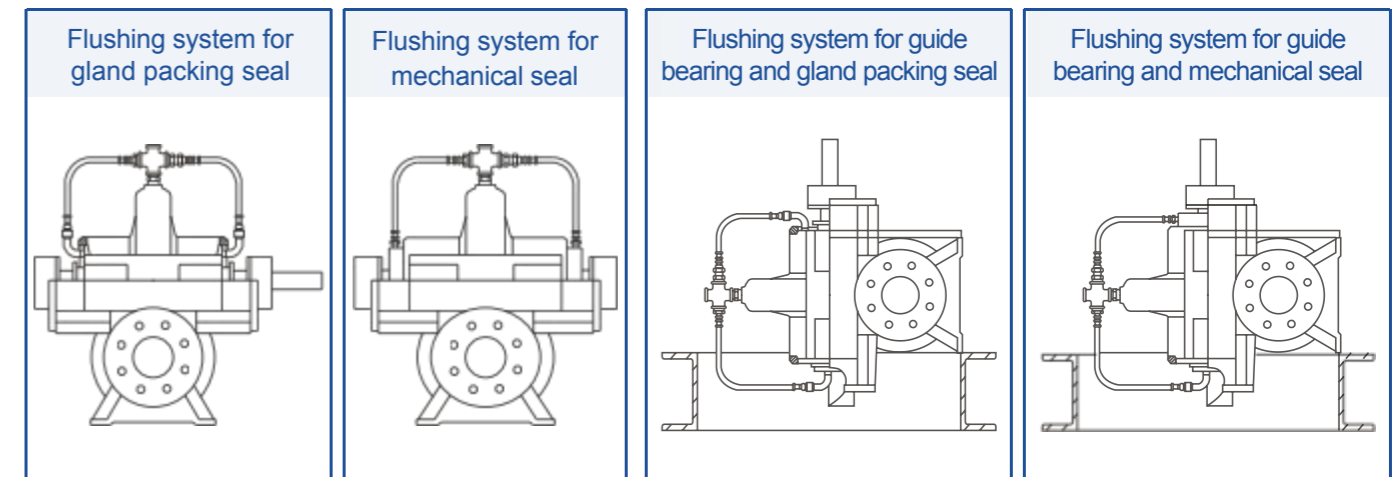

**Rotation Direction / Flow Direction**

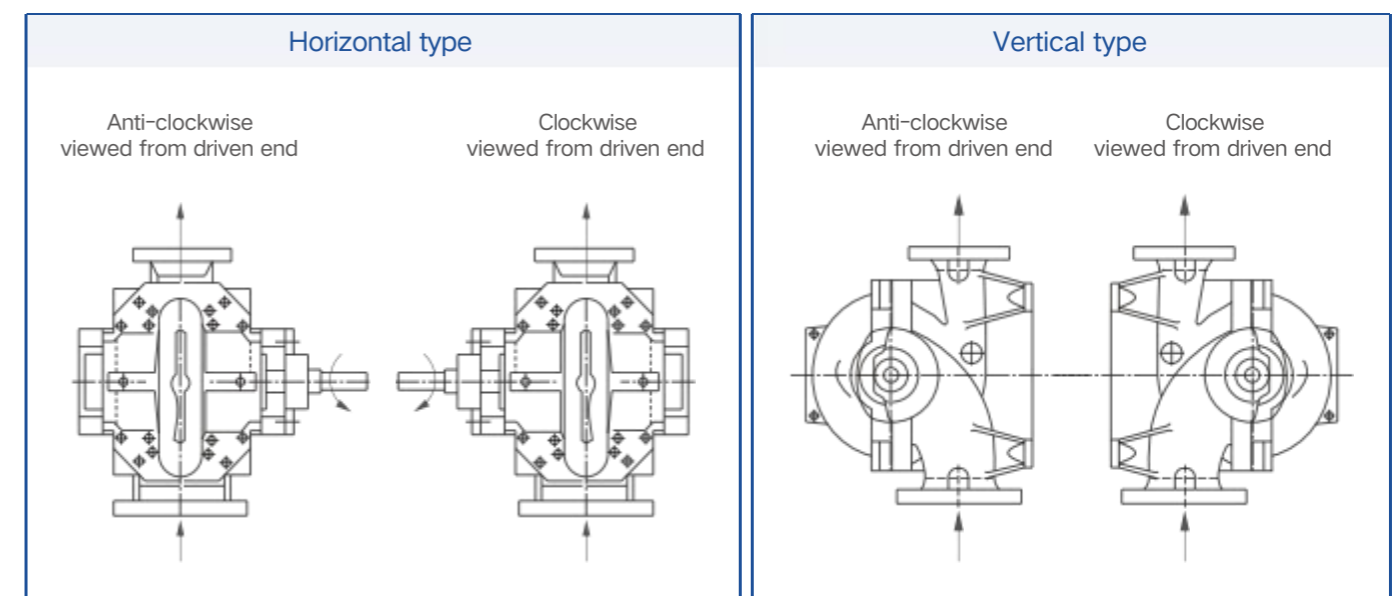

## The Construction Features of SBS Series with Discharge Flange ≤ DN350

### Impeller

- A. The double suction impeller with CFD technology balances the axial force automatically. The efficiency will be increased about 3-5%;
- B. The water is sucked in both sides of the impeller, and the impeller blades are placed alternately. This design reduces the flow pulsation, ensures the pump with stable performance;
- C. The water loss is reduced to minimum by using resin core, precision mould, shot blasting treatment;
- D. Different hydraulic model type impellers can be used in the same volute casing, which enlarges the high efficiency range;

- Independent seal chamber, realize automatic and precise positioning of pump cover and pump body. No need to adjust, easy to install.

- Gland packing seal or mechanical seal for options. The mechanical seal can be single face or double faces. With heat exchanger, high temperature water can be pumped (below 130°C).

- The pump shaft with reliability design increases the strength level. Small span, good rigidity and high stability.

- Reliable axial double seal design, respectively set between the shaft sleeve and impeller, the shaft sleeve and the shaft, effectively prevent axial water channeling, and realize the dry shaft design.

- Replaceable casing wearing ring protects the impeller and housing. The extended design reduces volume loss and ensures long-term efficient operation of the pump.

### Volute casing

- A. The pump casing is with robust design, the working pressure max. to 2.5MPa;
- B. The pump generating high pressure with dual casing balances the radial force;
- C. The innovative volute section angle is designed to the minimum neck load pulse;
- D. The compact design minimizes the distance between bearings, reduces the shaft torque force, strengthens the rigidity of the shaft;
- E. Inline design, the suction and discharge flange are in the same line, easy in installation;
- F. With special structure design, the pump can be installed in horizontal or vertical way;
- G. Resin molds, precision casting, shot blasting, smooth runners for minimal hydraulic losses;

- The left and right bearing housings are universal, which is convenient for management. The bearing temperature measuring device holes are reserved on the bearing housing of the both sides. The temperature measuring device can be installed according to the requirements of user. The operating temperature of the pump bearing can be monitored at any time.

- The stainless steel sealing flushing pipe is installed on the pump cover. Which is equipped with a flow control valve to adjust the sealing flushing amount at any time to effectively cool, flush and lubricate the seal.

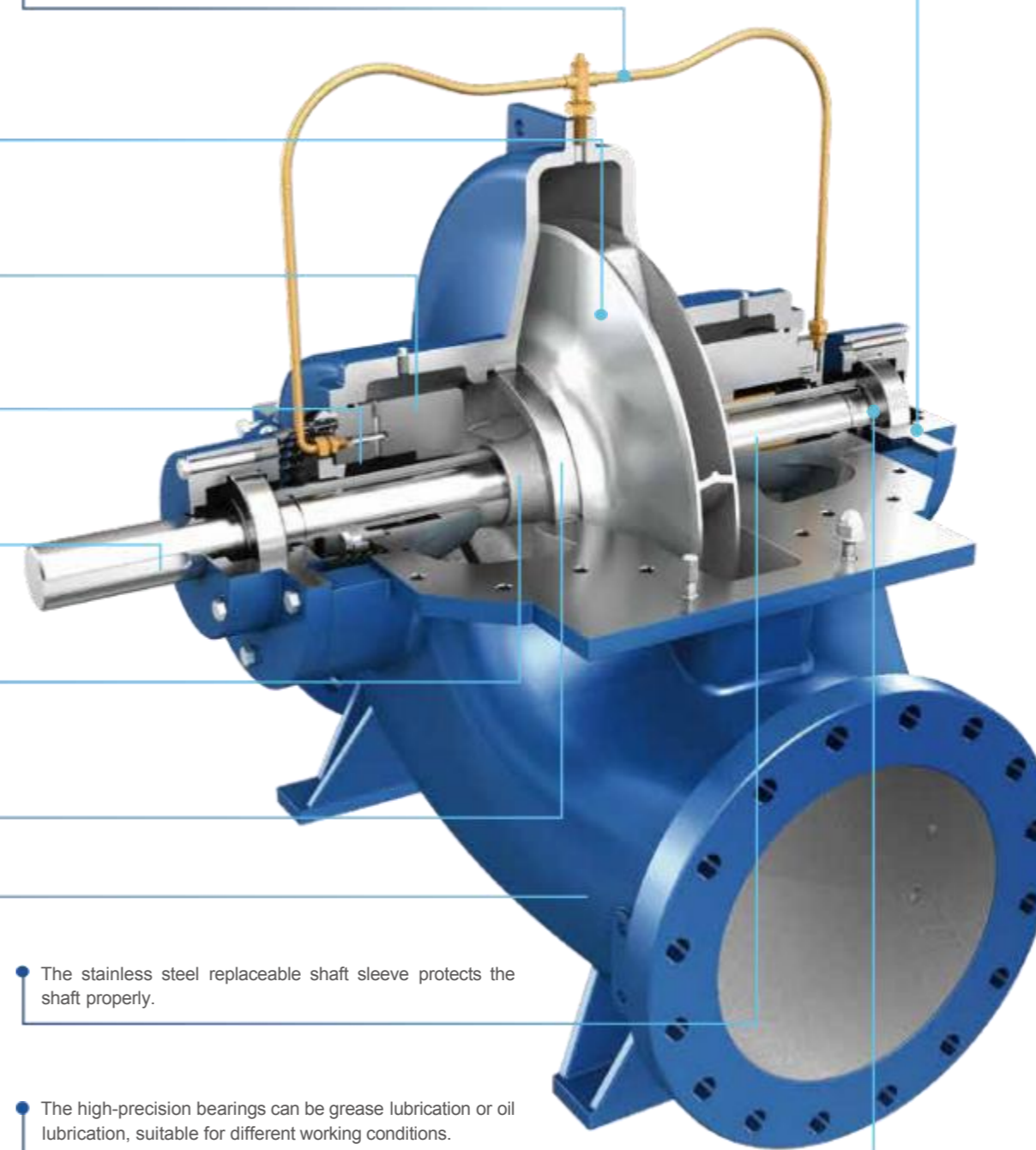

- The stainless steel replaceable shaft sleeve protects the shaft properly.

- The high-precision bearings can be grease lubrication or oil lubrication, suitable for different working conditions.

## The Construction Features of SBS Series with Discharge Flange $\geq$ DN350

### Impeller

- A. The double suction impeller with CFD technology balances the axial force automatically. The efficiency will be increased about 3-5%;
- B. The water is sucked in both sides of the impeller, and the impeller blades are placed alternately. This design reduces the flow pulsation, ensures the pump with stable performance;
- C. The water loss is reduced to minimum by using resin core, precision mould, shot blasting treatment;
- D. Different hydraulic model type impellers can be used in the same volute casing, which enlarges the high efficiency range.

- The bearing temperature measuring device holes are reserved on the bearing housing of the both sides. The temperature measuring device can be installed according to the requirements of user. The operating temperature of the pump bearing can be monitored at any time.

- The pump shaft with reliability design increases the strength level. Small span, good rigidity and high stability.

- The high-precision bearings can be grease lubrication or oil lubrication, suitable for different working conditions.

- The stainless steel replaceable shaft sleeve protects the shaft properly.

### Volute casing

- A. The pump casing is with robust design, the working pressure max. to 2.5MPa;
- B. The pump generating high pressure with dual casing balances the radical force;
- C. The innovative volute section angle is designed to the minimum neck load pulse;
- D. Resin molds, precision casting, shot blasting, smooth runners for minimal hydraulic losses.

- Gland packing seal or mechanical seal for options. The mechanical seal can be single face or double faces. With heat exchanger, high temperature water can be pumped (below 130°C).

- Replaceable casing wearing ring protects the impeller and housing. The extended design reduces volume loss and ensures long-term efficient operation of the pump.

- The stainless steel sealing flushing pipe is installed on the pump cover. Which is equipped with a flow control valve to adjust the sealing flushing amount at any time to effectively cool, flush and lubricate the seal.

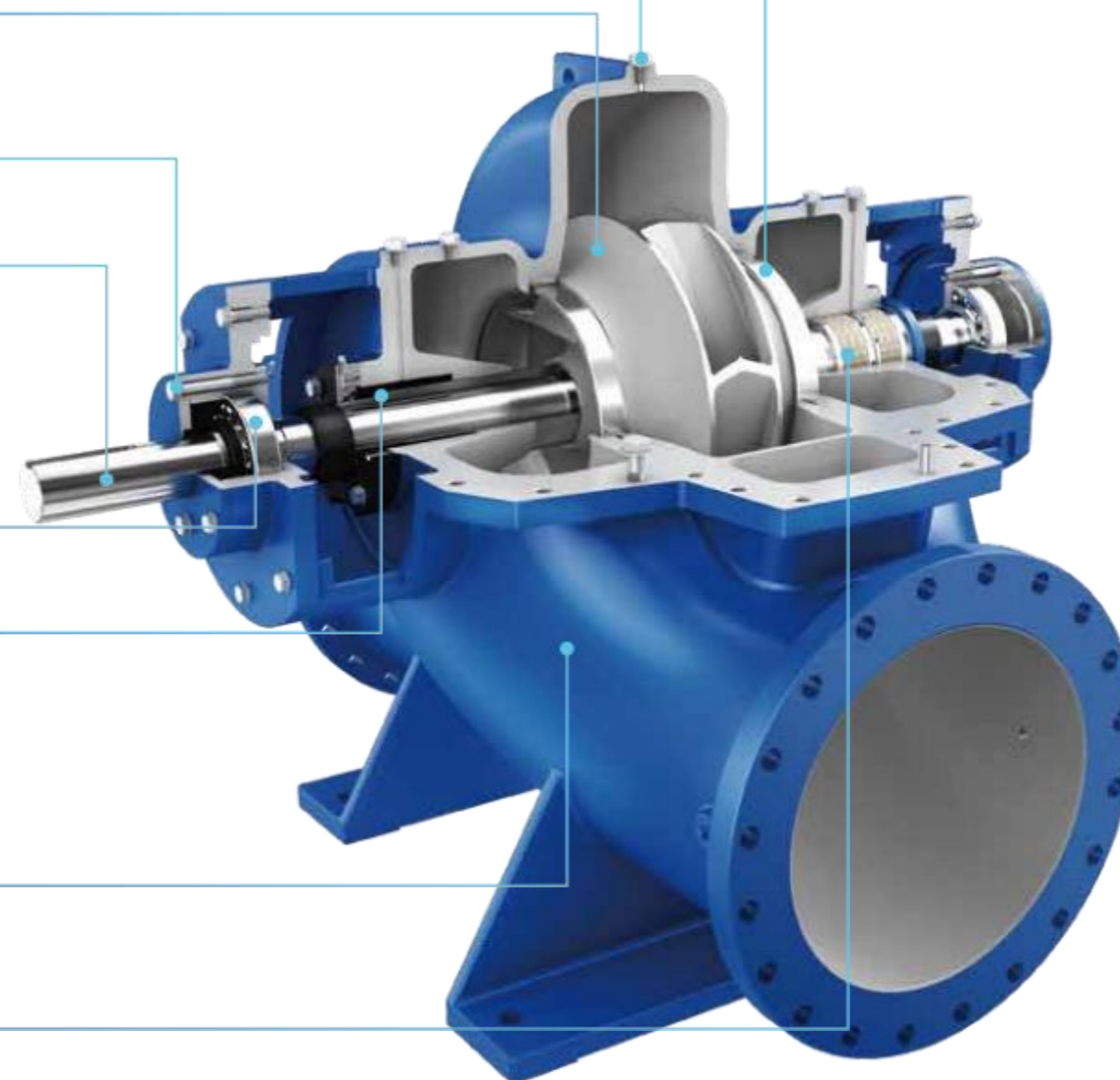

## The Construction Features of SBSL Series Vertical Split Casing Pump

- Strong and reliable motor support frame, with enhanced design to improve the reliability.
- The pump shaft is with high reliability to increase the strength ratings.
- High-precision bearings, long service life.
- Gland packing seal or mechanical seal for options. The mechanical seal can be single face or double faces. With heat exchanger, high temperature water can be pumped(below 130°C).
- The replaceable casing wearing ring protects the impeller and housing.The extended design reduces volume loss and ensures long-term efficient operation of the pump.
- **Impeller**
  - A. The double suction impeller with CFD technology balances the axial force automatically. The efficiency will be increased about 3-5%;
  - B. The water is sucked in both sides of the impeller, and the impeller blades are placed alternately. This design reduces the flow pulsation, ensures the pump with stable performance;
  - C. Resin molds, precision casting, shot blasting, smooth runners for minimal hydraulic losses;
  - D. Different hydraulic model type impellers can be used in the same volute casing,which enlarges the high efficiency range.
- **Volute casing**
  - A. The pump casing is with robust design, the working pressure max. to 2.5MPa;
  - B. The pump generating high pressure with dual casing balances the radical force;
  - C. The innovative volute section angle is designed to the minimum neck load pulse;
  - D. Resin molds, precision casting, shot blasting, smooth runners for minimal hydraulic losses.
- The stainless steel replaceable shaft sleeve protects the shaft properly.
- The high-strength design of the base plate keeps the stability of the equipment.

- The auxiliary support makes the pump run more stable and reliable.
- The stainless steel sealing flushing pipe is installed on the pump cover. Which is equipped with a flow control valve to adjust the sealing flushing amount at any time to effectively cool, flush and lubricate the seal.

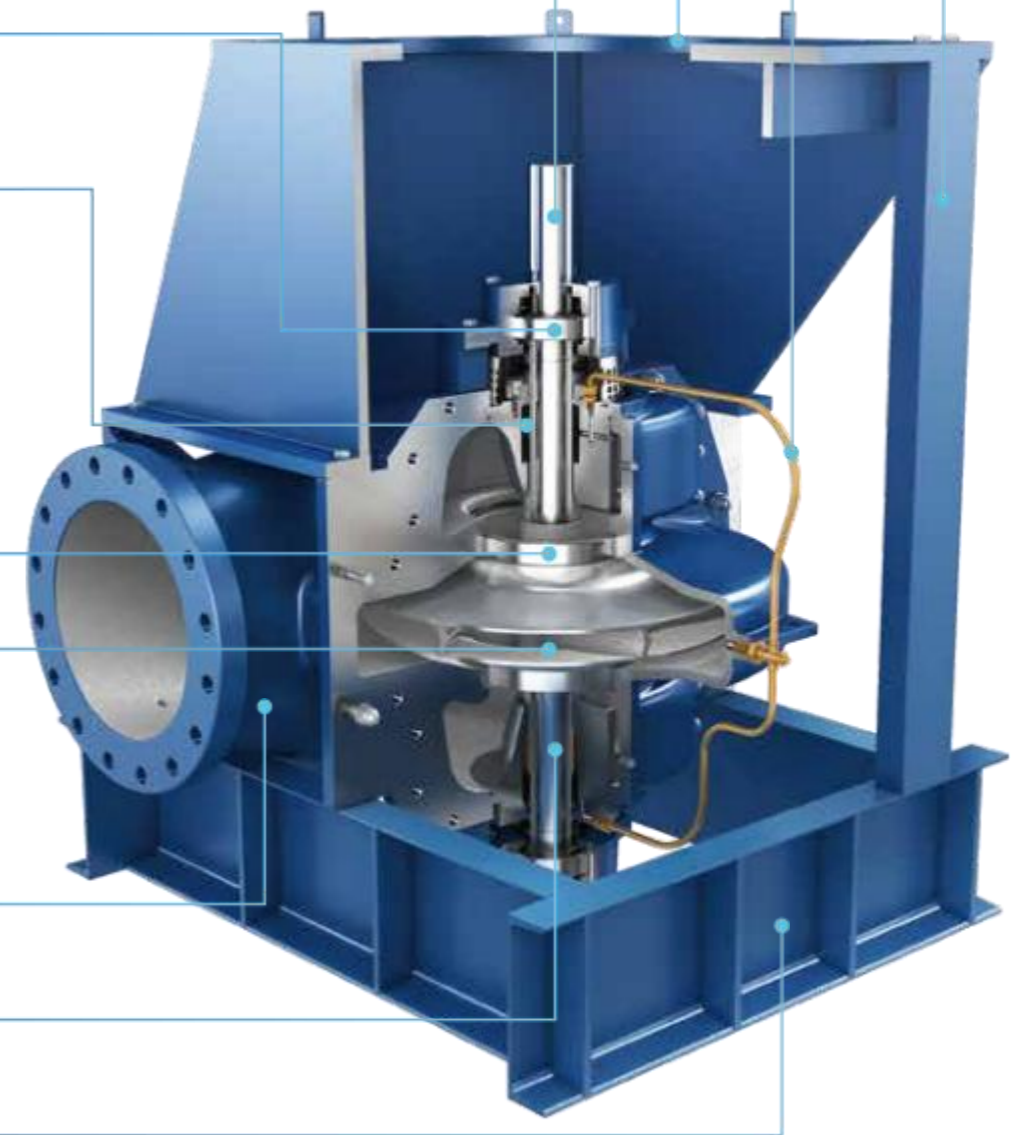

SBS80-210 EG Performance Curve n=2900r/min

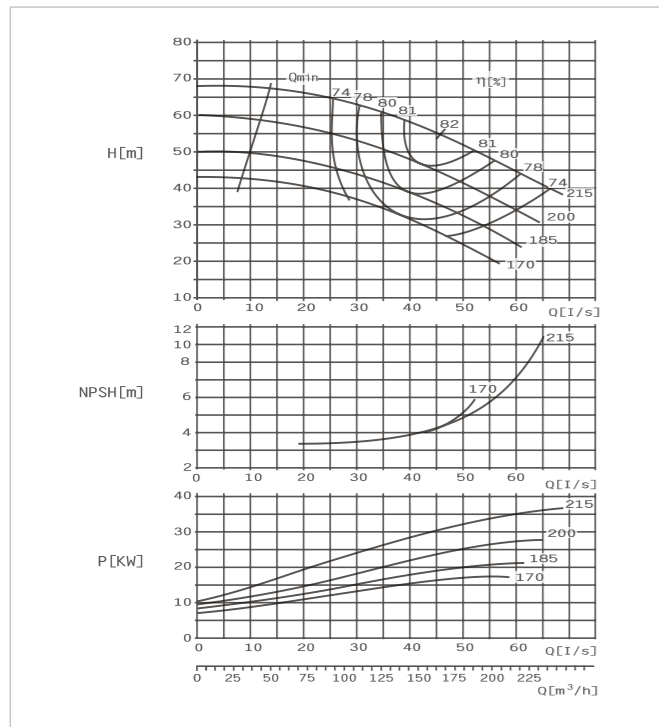

SBS80-210 FG Performance Curve n=2900r/min

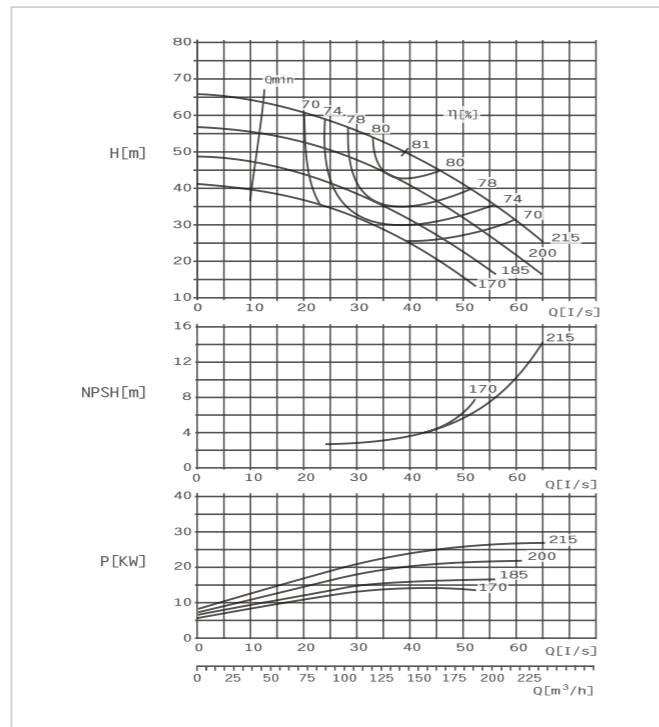

SBS80-270 EG Performance Curve n=2900r/min

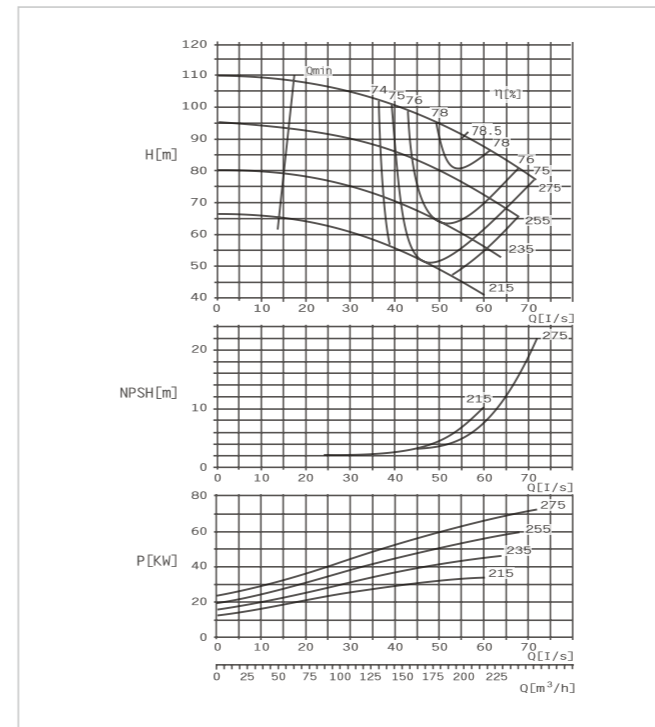

SBS80-270 FG Performance Curve n=2900r/min

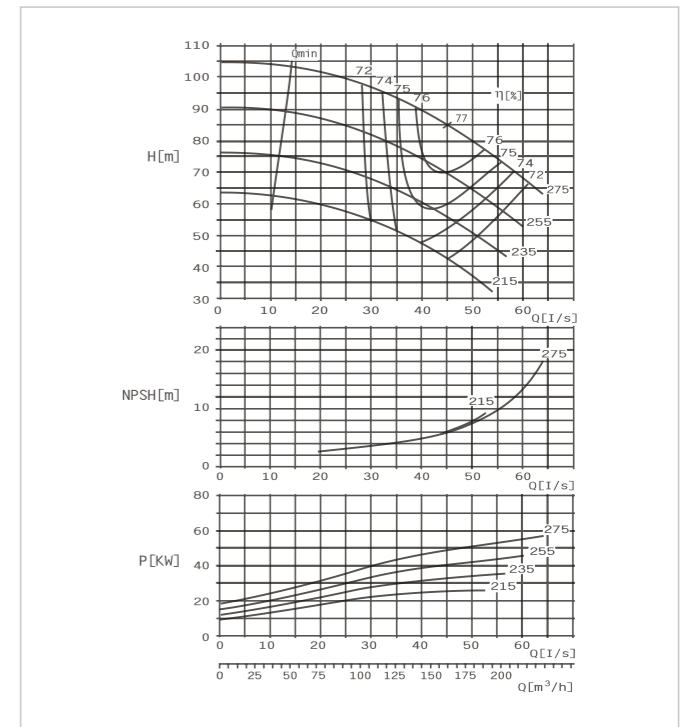

**SBS Horizontal pump installation dimension drawing**

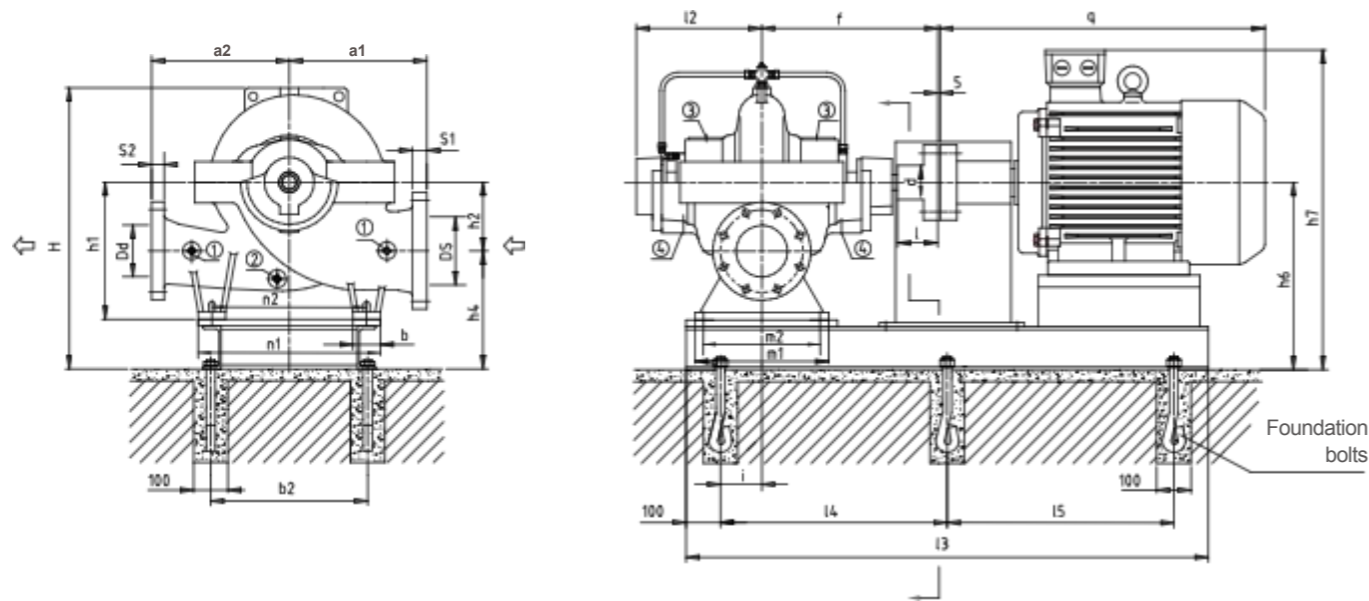

Suction flange

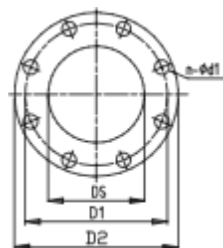

Discharge flange

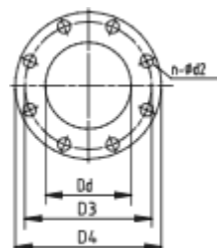

**Connection Dimensions**

- ① Pressure gauge Rp1/2
- ② Drain plug Rp1/2
- ③ Air vent Rp1/2
- ④ Leakage drains hole Rp3/4

**Parameter Chart**

Model	Capacity		Head	Speed	Eff.	Motor power	NPSH	Impeller diameter
	m³/h	L/S						
SBS 80-210EG	131	36.4	60.5	2900	80.6	37	5.1	215
	164	45.6	55		82			
	197	54.6	50		80.2			
	121	33.6	52		79.3			
	151	42	47.5		81			
	181	50.4	42.2		80			
	115	32	44		77.8			
	144	40	39		80.5			
	173	48	35		78			
	110	30.6	37		75.3			
137	38	33.5	77.8					
164	45.6	27.7	74					
SBS 80-210FG	107	29.7	55.5	2900	79	30	4	215
	134	37.1	51		81			
	160	44.5	46		80.1			
	106	29.4	47.7		78.2			
	133	36.9	43.5		80			
	159	44.2	37		80.1			
	100	27.8	40		75.5			
	124	34.5	36		78.2			
	149	41.4	30		74			
	91	25.2	35		71.5			
133	31.5	31	74					
136	37.8	27	72					

**Parameter Chart**

Model	Capacity		Head	Speed	Eff.	Motor power	NPSH	Impeller diameter
	m³/h	L/S						
SBS 80-270EG	166	46.1	97.5	2900	77.2	75	7	275
	207	57.5	90		78.5			
	248	69	79		75.5			
	156	43.2	83.5		76			
	194	54	77		77.5			
	233	64.8	69		75.5			
	147	40.8	70		74.7			
	184	51	63.5		76			
	220	61.2	55		74			
	138	38.4	56.5		74.2			
173	48	50	75					
198	55	45	74					
SBS 80-270FG	137	38	91	2900	76.1	75	7.3	275
	171	47.5	82.5		77			
	205	57	72.5		75			
	122	34	79.5		74.4			
	153	42.5	71.5		76.2			
	184	51	67		76			
	115	31.9	66.8		73.7			
	144	40	60		75.2			
	173	48.1	53		74.2			
	110	30.6	54.5		72.5			
137	38.1	49	74.4					
164	45.6	42	72.5					

**Dimensions**

Model	Suction flange ( mm )					Discharge flange ( mm )					Pump size ( mm )										WGT		
	DS	D1	D2	n-φd1	S1	Dd	D3	D4	n-φd2	S2	m1	m2	n1	n2	b	a1	a2	l2	f	h1		h2	H
80-210	125	210	250	8-φ18	31	80	160	200	8-φ18	27	320	270	410	340	70	300	300	310	385	315	140	600	219
80-270	125	210	250	8-φ18	31	80	160	200	8-φ18	27	320	270	410	340	70	300	300	310	385	315	140	600	226

**Installation dimensions**

Model	Motor		b2	h4	h6	h7	l3	l4	l5	i	q	Motor weight (kg)	Baseplate weight (kg)	Coupling d×l	Foudation bolts
	Frame Size	Power (kW)													
80-210G	160M	15	430	295	435	700	1050	425	70	665	140	130	132	Ø39×80	6-M16×350
	160L	18.5				700	1100	450							
	180M	22				720	1110	455							
	200L	30/37				765	1190	495							
	225M	45				815	1230	515							
	250M	55				820	1320	560							
	280S	75				880	1390	595							
80-270G	160M	15	530	315	455	700	1050	425	70	665	140	130	132	Ø39×80	6-M16×350
160L	18.5	700				1100	450								
180M	22	720				1110	455								
200L	30/37	765				1190	495								
225M	45	815				1230	515								
250M	55	820				1320	560								
280S	75	880				1390	595								

SBS100-250 EG Performance Curve n=2900r/min

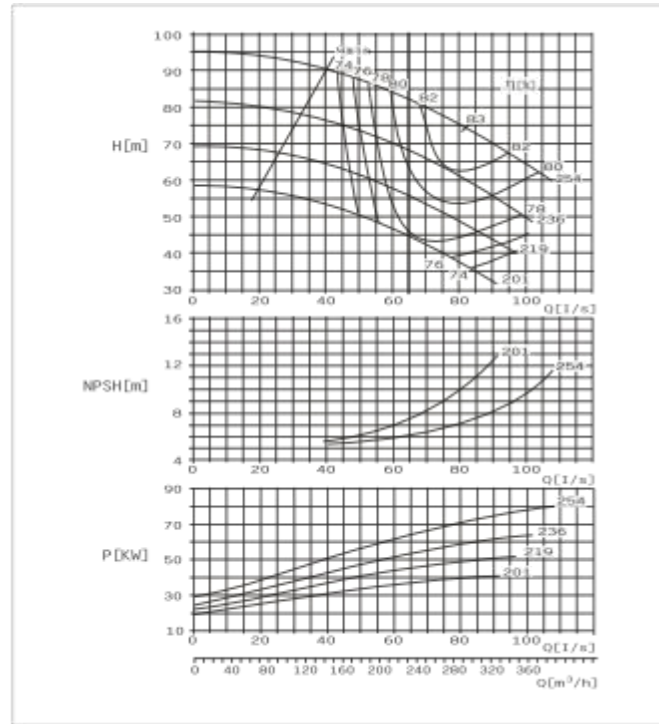

SBS100-310 EG Performance Curve n=2900r/min

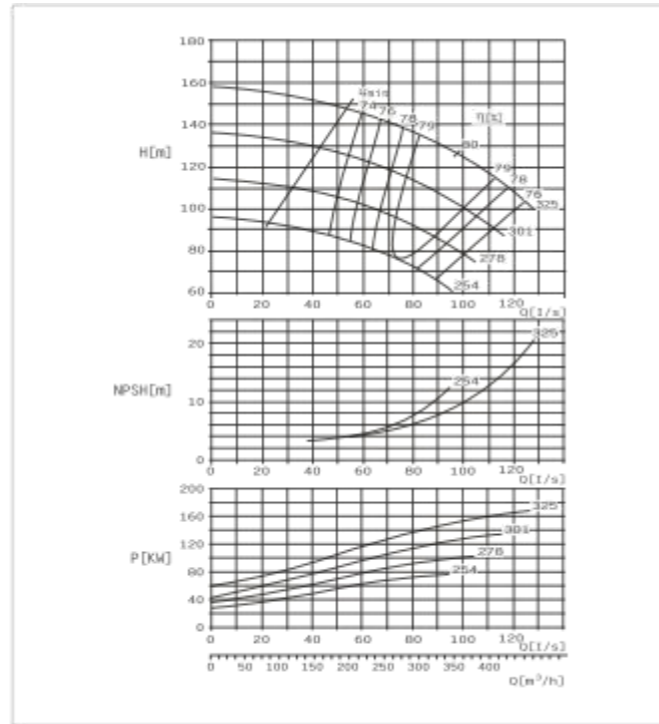

SBS100-325 EG Performance Curve n=2900r/min

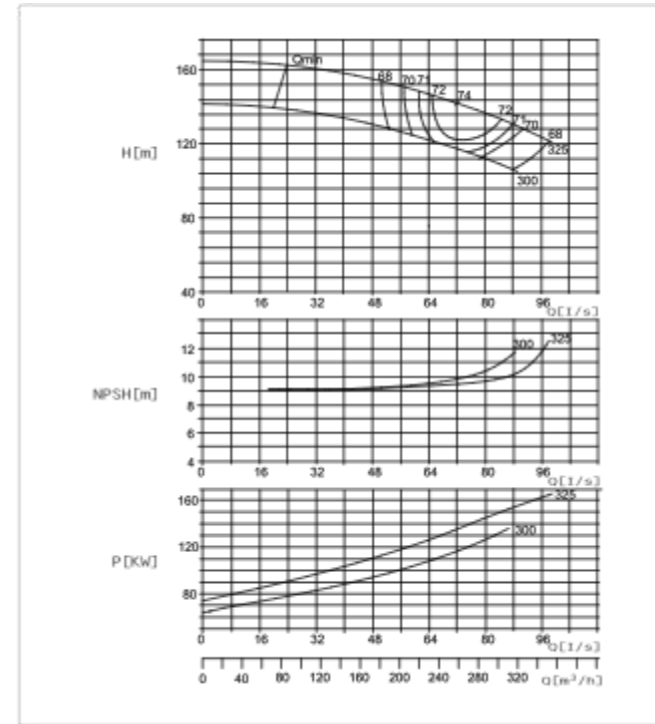

SBS100-345 EG Performance Curve n=2900r/min

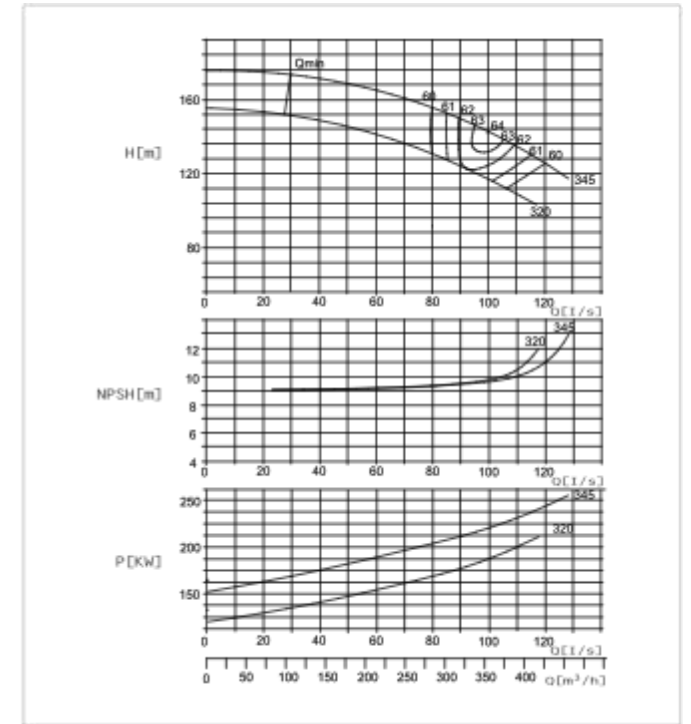

SBS Horizontal pump installation dimension drawing

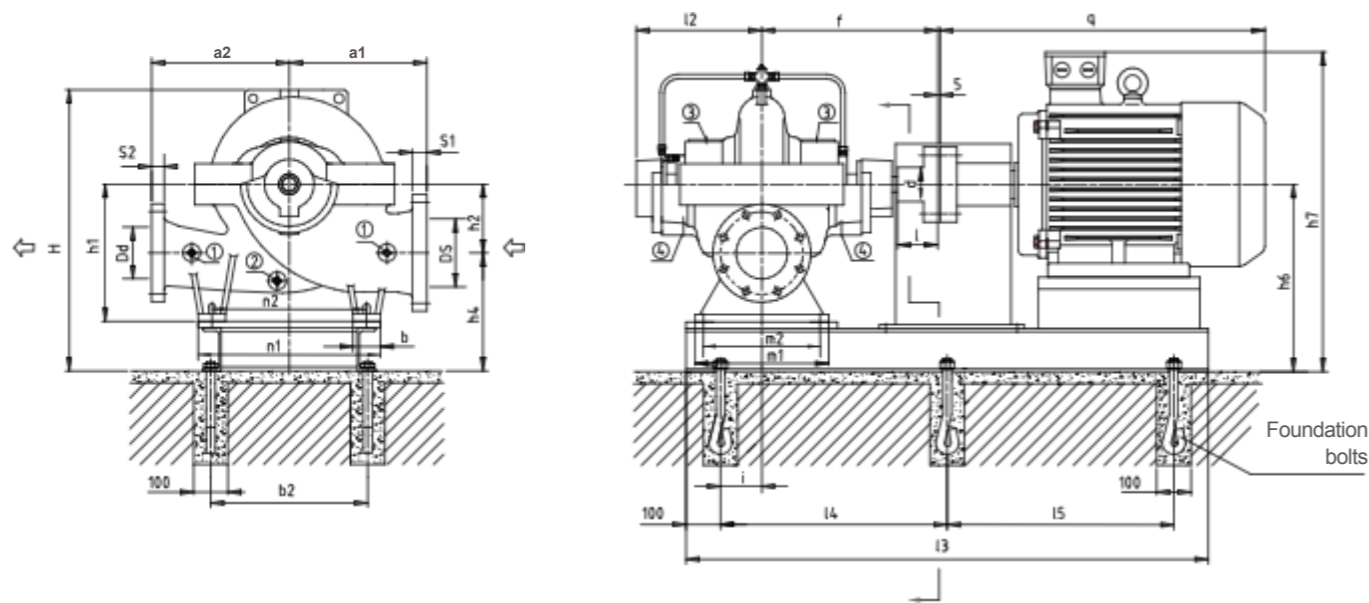

Suction flange

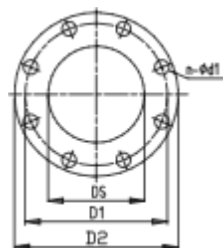

Discharge flange

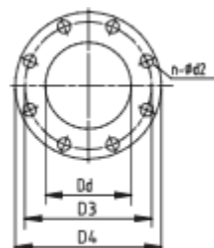

**Connection Dimensions**

- ① Pressure gauge Rp1/2
- ② Drain plug Rp1/2
- ③ Air vent Rp1/2
- ④ Leakage drains hole Rp3/4

**Parameter Chart**

Model	Capacity		Head	Speed	Eff.	Motor power	NPSH	Impeller diameter		
	m³/h	L/S	m	r/min	%	kW	m	mm		
SBS 100- 250EG	230	64	83	2900	80.7	90	9	254		
	288	80	75		83					
	346	96	67		80.5					
	219	60.8	69		79.3	75			9.5	
	274	76	63		80.5					
	328	91.2	55		79					
	209	58	59		77.2	55				9.7
	261	72.5	52		77					
	313	87	46.5		77					
	193	53.6	49		76	45				
240	66.7	45	78							
290	80.6	37	74.5							
SBS 100- 310EG	294	81.6	135	2900	78.5	185	13.7	325		
	367	102	123		80					
	440	122.2	105		76.8					
	268	74.4	116		78.3	160			12.2	
	335	93	106		79.6					
	402	111.7	92		77					
	242	67.2	98		78.1	110				10.7
	302	83.9	90		79.3					
	363	100.8	80		77.2					
	182	50.5	82		77	90				
227	77	74	78.3							
333	92.4	65.5	76							

**Parameter Chart**

Model	Capacity		Head	Speed	Eff.	Motor power	NPSH	Impeller diameter		
	m³/h	L/S	m	r/min	%	kW	m	mm		
SBS 100- 325EG	205	56.9	150	2900	70.2	160	10.5	325		
	256	71.1	142		74.5					
	307	85.3	133		72.5					
	189	52.5	128		68.2				132	10.1
	236	65.6	121		71.5					
SBS 100- 345EG	288	80.0	156.0	2900	60	250	11	345		
	360	100.0	143.0		64					
	432	120.0	125.0		60					
	267	74.2	134.2		59				200	10
	334	92.8	123.0		62					
	401	111.3	108.0		59					

**Dimensions**

Model	Suction flange ( mm )					Discharge flange ( mm )					Pump size ( mm )								WGT kg				
	DS	D1	D2	n-φd1	S1	Dd	D3	D4	n-φd2	S2	m1	m2	n1	n2	b	a1	a2	l2		f	h1	h2	H
100-(250-325)	150	240	285	8-φ23	31	100	180	220	8-φ18	29	320	270	470	400	70	330	330	310	385	355	170	665	257
100-345	150	240	285	8-φ23	31	100	180	220	8-φ18	29	320	270	470	400	70	370	370	310	385	355	170	735	270

**Installation dimensions**

Model	Motor		b2	h4	h6	h7	I3	I4	I5	i	q	Motor weight (kg)	Baseplate weight (kg)	Coupling d×l	Foudation bolts
	Frame Size	Power (kW)													
100- 310EG	200L	37	500	325	495	805	1190	495	790	70	790	270	145	Ø39×80	6-M20×400
	225M	45													
	250M	55													
	280S	75													
	280M	90													
	315S	110													
	315M	132													
	315L	160													
	315L	160													
	355M	250													

SBS125-230 EG Performance Curve n=2900r/min

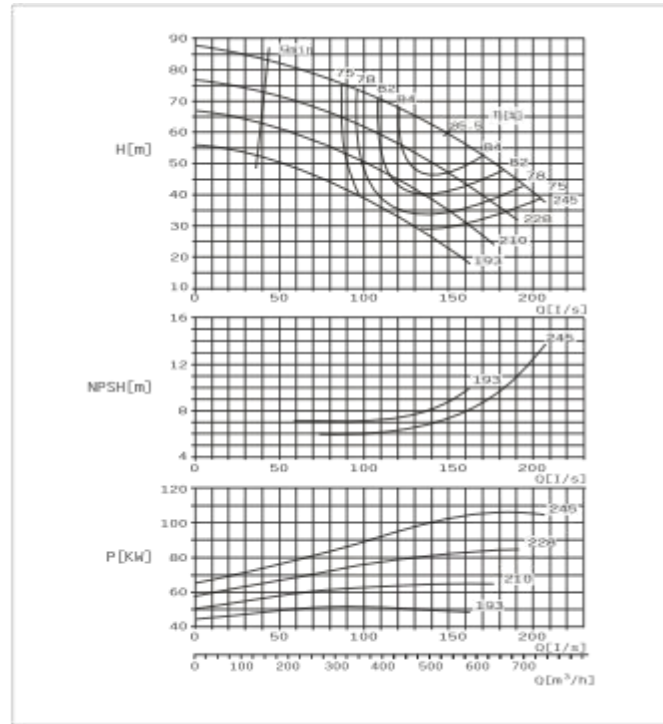

SBS125-290 EG Performance Curve n=2900r/min

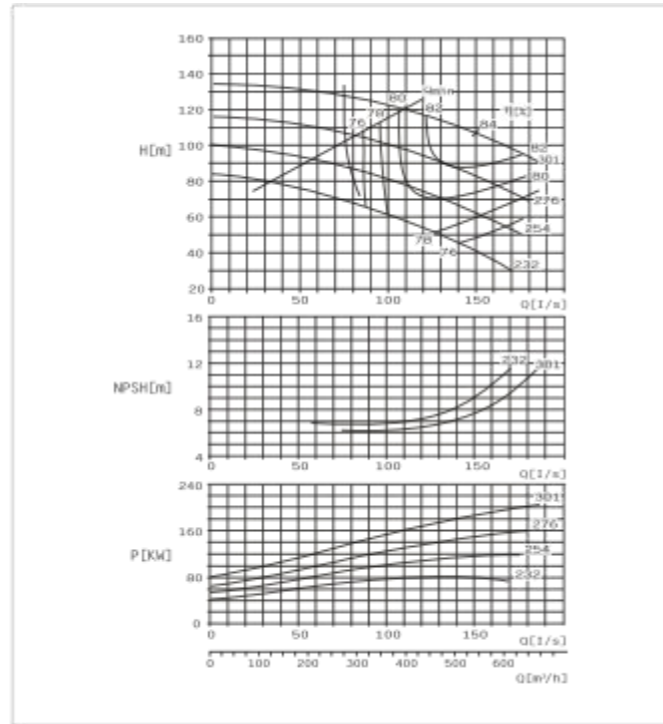

SBS125-400 EG Performance Curve n=2900r/min

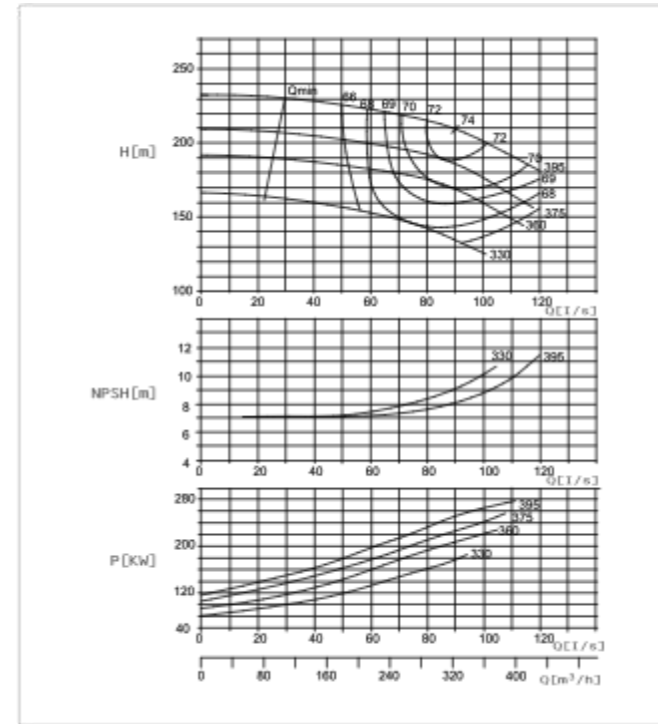

SBS150-330 EG Performance Curve n=2900r/min

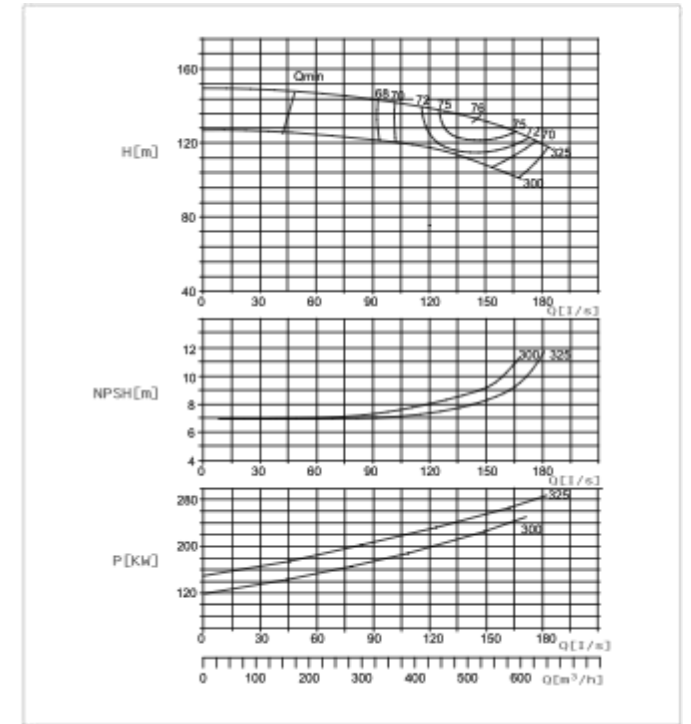

**SBS Horizontal pump installation dimension drawing**

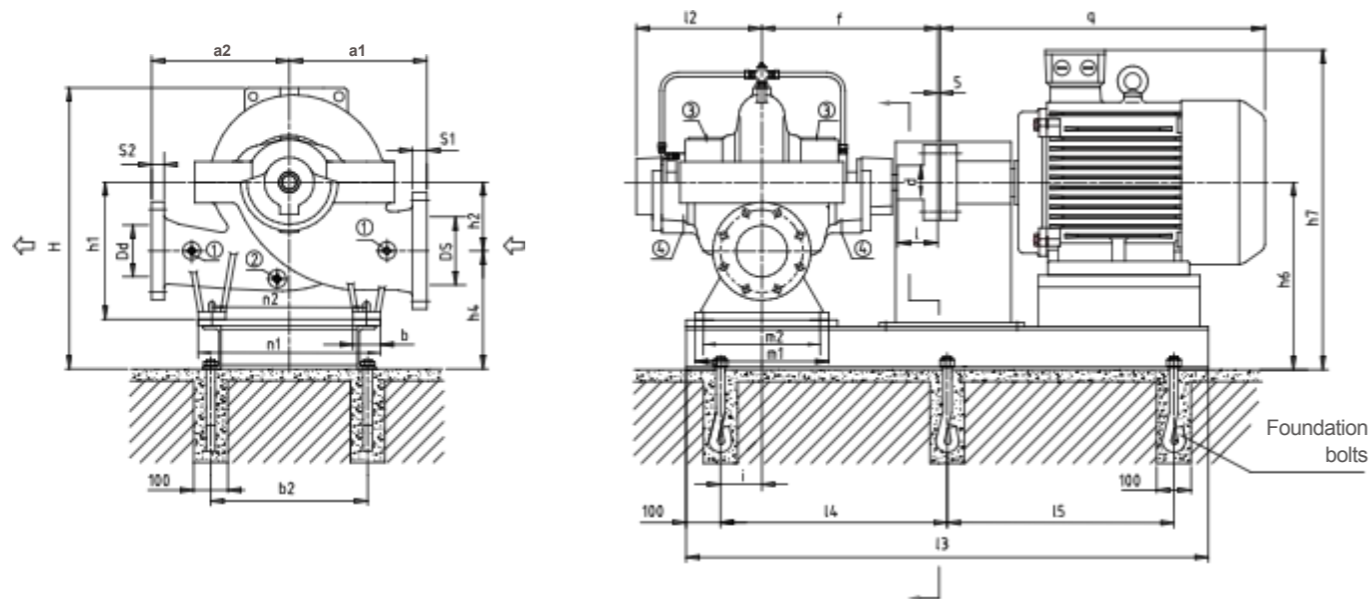

Suction flange

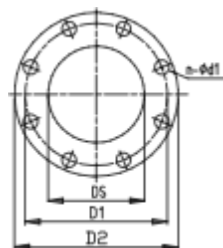

Discharge flange

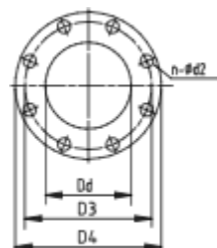

**Connection Dimensions**

- ① Pressure gauge Rp1/2
- ② Drain plug Rp1/2
- ③ Air vent Rp1/2
- ④ Leakage drains hole Rp3/4

**Parameter Chart**

Model	Capacity		Head m	Speed r/min	Eff. %	Motor power kW	NPSH m	Impeller diameter mm
	m³/h	L/S						
SBS 125-230EG	426	118.4	68	2900	84.2	110	9.9	245
	541	150.3	60		85.5			
	639	177.6	48		82			
	392	108.8	60		82			
	490	136.1	52		84			
	585	163.2	43.5		82.5			
	363	100.8	50		78			
	454	126	43.5		82			
	544	151.2	35		78			
	340	94.4	40		75			
SBS 125-290EG	428	118.8	117	2900	82	200	10.9	301
	535	148.5	108		84			
	640	178.3	94		83			
	397	110.3	97		80			
	497	138	88		82			
	596	165.6	75		79.5			
	363	100.8	80		78.3			
	454	126	72		80			
	544	151.2	62		78.8			
	323	89.6	65		76.5			
SBS 125-400EG	400	111.1	142	2900	70.2	185	9.8	330
	500	138.9	135		76.0			
	600	166.7	126		75.0			
	233	64.7	181		69.0			
	292	81.1	175		70.0			
	350	97.2	155		69.0			
	214	59.4	153		67.0			
	267	74.2	146		68.0			
	321	89.2	135		67.2			

**Parameter Chart**

Model	Capacity		Head m	Speed r/min	Eff. %	Motor power kW	NPSH m	Impeller diameter mm
	m³/h	L/S						
SBS 150-330EG	256	71.1	219	2900	70.0	280	8.9	395
	320	88.9	210		73.0			
	384	106.7	190		72.0			
	243	67.5	197		69.0			
	304	84.4	190		72.0			
	365	101.4	175		71.5			
	233	64.7	181		69.0			
	292	81.1	175		70.0			
	350	97.2	155		69.0			
	214	59.4	153		67.0			
SBS 150-400EG	400	111.1	142	2900	70.2	250	9	300
	500	138.9	135		76.0			
	600	166.7	126		75.0			
	369	102.6	121		68.2			
	462	128.2	115		71.5			
	554	153.8	107		70.0			

**Dimensions**

Model	Suction flange ( mm )					Discharge flange ( mm )					Pump size ( mm )										WGT kg		
	DS	D1	D2	n-φd1	S1	Dd	D3	D4	n-φd2	S2	m1	m2	n1	n2	b	a1	a2	l2	f	h1		h2	H
125-230/290	200	295	340	12-φ23	35	125	210	250	8-φ18	31	390	340	530	450	80	370	370	370	515	400	200	710	350
125-400	200	295	340	12-φ26	40	125	210	250	8-φ18	33	390	340	530	450	80	450	450	370	515	400	200	730	408
150-330	200	295	340	12-φ23	35	150	240	285	8-φ23	31	390	340	530	450	80	400	400	370	515	400	200	770	374

**Installation dimensions**

Model	Motor		b2	h4	h6	h7	l3	l4	l5	i	q	Motor weight (kg)	Baseplate weight (kg)	Coupling d×l	Foundation bolts		
	Frame Size	Power (kW)															
125-290G	230G	280M	90	560	340	540	965	1580	690	105	790	630	206	φ44×100	6-M20×400		
		315S	110													1620	710
		315M	132													1697	735
		315L	160-200													1700	750
		355M	220-250													1780	820
150-330G	355L	280	700	380	580	1780	1840	820	1600	1640	350						
125-400G	355L	280	700	380	580	1780	1840	820	1600	1780	360						

SBS80-210 E Performance Curve n=1450r/min

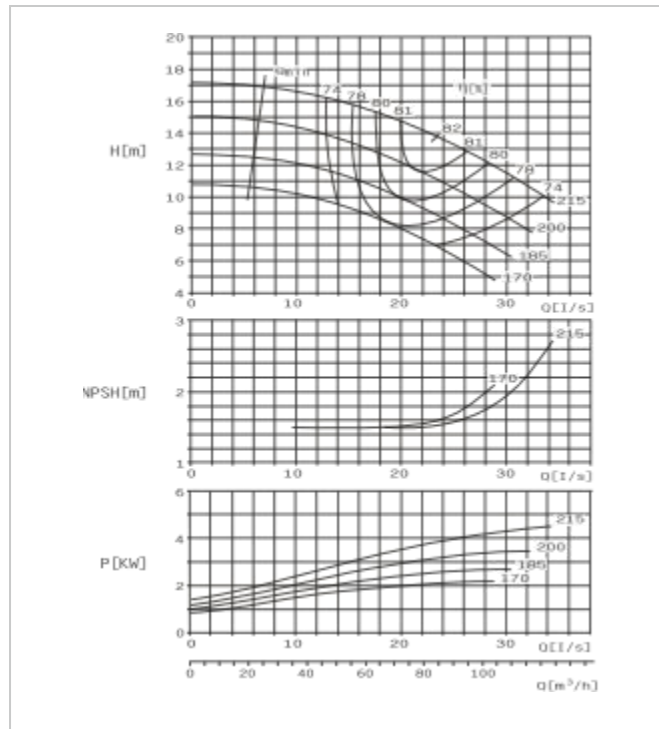

SBS80-210 F Performance Curve n=1450r/min

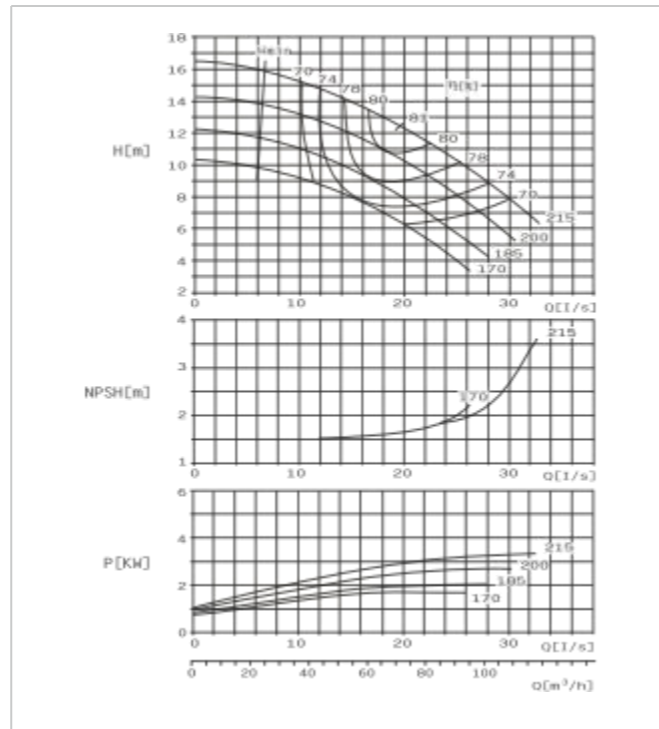

SBS80-270 E Performance Curve n=1450r/min

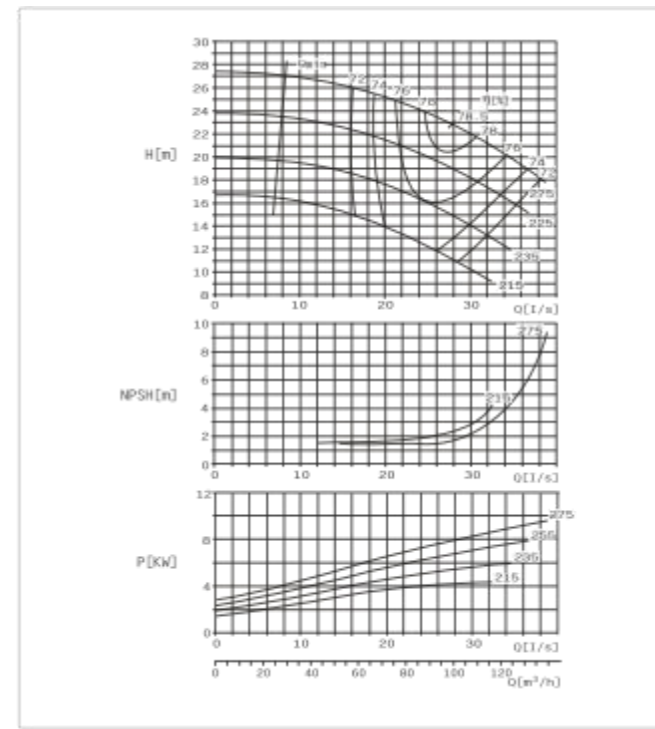

SBS80-270 F Performance Curve =1450r/min

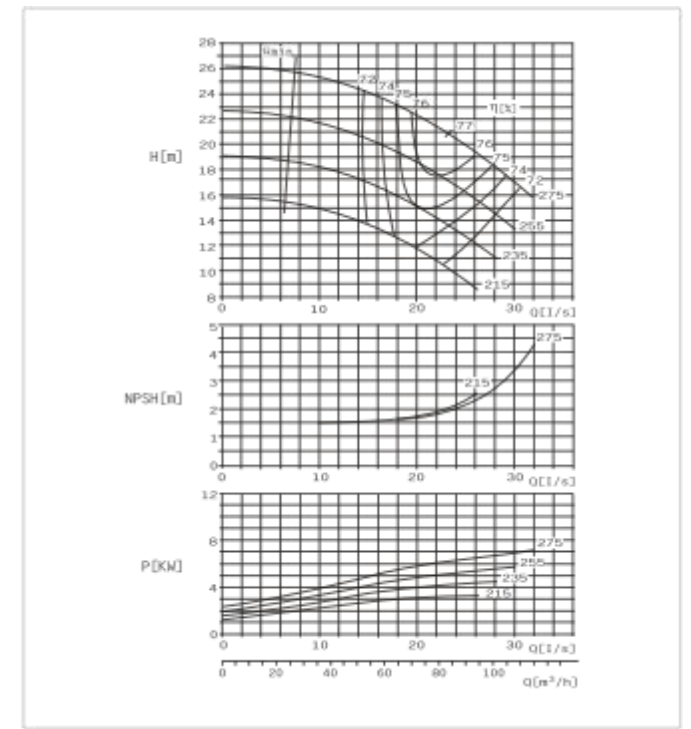

**SBS Horizontal pump installation dimension drawing**

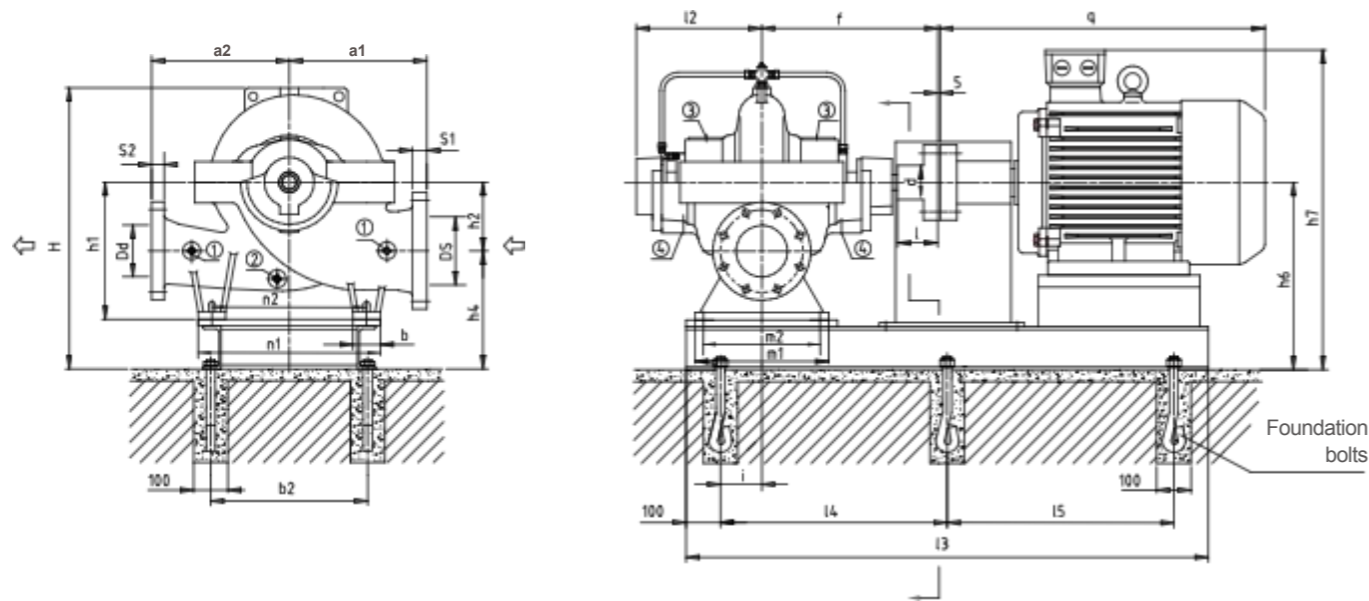

Suction flange

Discharge flange

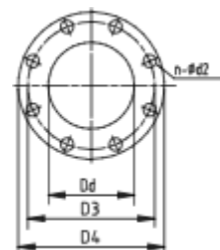
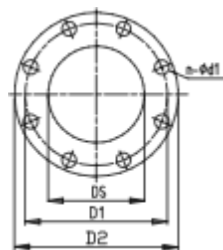

**Connection Dimensions**

- ① Pressure gauge Rp1/2
- ② Drain plug Rp1/2
- ③ Air vent Rp1/2
- ④ Leakage drains hole Rp3/4

**Parameter Chart**

Model	Capacity		Head	Speed	Eff.	Motor power	NPSH	Impeller diameter
	m³/h	L/S						
SBS 80-210E	66	18.3	15	1450	80.5	5.5	2.1	215
	83	23.1	13.8		79.5			
	100	27.8	12.2		79			
	61	16.9	13		81			
	76	21.1	11.8		79.7			
	90	25	10.5		78			
	58	16.1	11		78			
	72	20	9.8		80.5			
	87	24.2	8.7		78			
	55	15.3	9.1		76			
69	19.2	8.2	78					
83	23.1	7	75					
SBS 80-210F	52	14.5	14.2	1450	78	4	2.1	215
	65	18.1	12.8		81			
	78	21.7	10		80.2			
	52	14.4	12		78.5			
	64	17.8	11.8		80			
	77	21.4	11.7		78			
	50	13.9	10		76			
	61	17	9		78			
	73	20.3	7.8		76.2			
	47	13.1	8.7		70			
58	16.1	7.6	74					
70	19.4	6.5	71					

**Parameter Chart**

Model	Capacity		Head	Speed	Eff.	Motor power	NPSH	Impeller diameter
	m³/h	L/S						
SBS 80-270E	83	23.1	24	1450	77.5	11	2.8	275
	104	28.9	22.5		78.5			
	125	34.7	19.5		75			
	80	22.2	21.3		75			
	99	27.8	19		78			
	120	33.3	17		74.5			
	72	20	17.5		74.5			
	90	25	16		76			
	108	30	13.7		74			
	67	18.6	13.8		74			
84	23.3	13	75					
100	27.8	11.5	73.2					
SBS 80-270F	68	18.9	23.1	1450	75.8	7.5	2.4	275
	95	23.6	20.7		77			
	102	28.3	18.2		75.4			
	61	16.9	20		74.5			
	77	21.4	18.1		76			
	92	25.5	16		75			
	58	16.1	16.5		73			
	72	20	15		75			
	86	23.9	13.2		74			
	53	14.7	13.8		72			
67	18.6	12.5	74					
80	22.2	10.8	73					

**Dimensions**

Model	Suction flange ( mm )					Discharge flange ( mm )					Pump size ( mm )										WGT kg		
	DS	D1	D2	n-φd1	S1	Dd	D3	D4	n-φd2	S2	m1	m2	n1	n2	b	a1	a2	l2	f	h1		h2	H
80-210	125	210	250	8-φ18	31	80	160	200	8-φ18	27	320	270	410	340	70	300	300	310	385	315	140	600	219
80-270	125	210	250	8-φ18	31	80	160	200	8-φ18	27	320	270	410	340	70	300	300	310	385	315	140	600	226

**Installation dimensions**

Model	Motor		b2	h4	h6	h7	l3	l4	l5	i	q	Motor weight (kg)	Baseplate weight (kg)	Coupling d×l	Foundation bolts
	Frame Size	Power (kW)													
80-270	210	100L	2.2/3	430	295	435	620	880	340	70	435	45	116	φ39×80	6-M20×400
		112M	4				638	890	345		410	55	116		
		132S	5.5				658	930	365		510	75	118		
		132M	7.5				658	970	385		525	88	122		
		160M	11				700	1050	425		670	132	128		

SBS80-370 E Performance Curve n=1450r/min

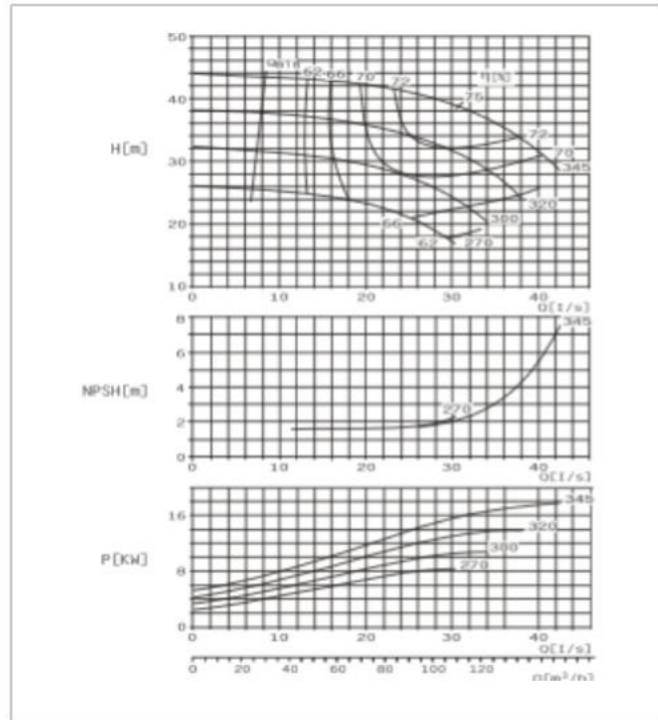

SBS80-370 F Performance Curve n=1450r/min

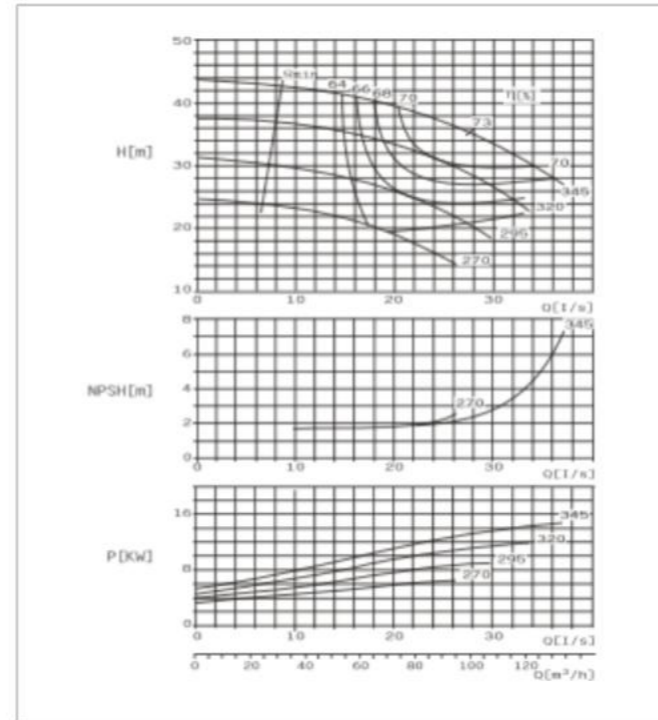

SBS100-250 E Performance Curve n=1450r/min

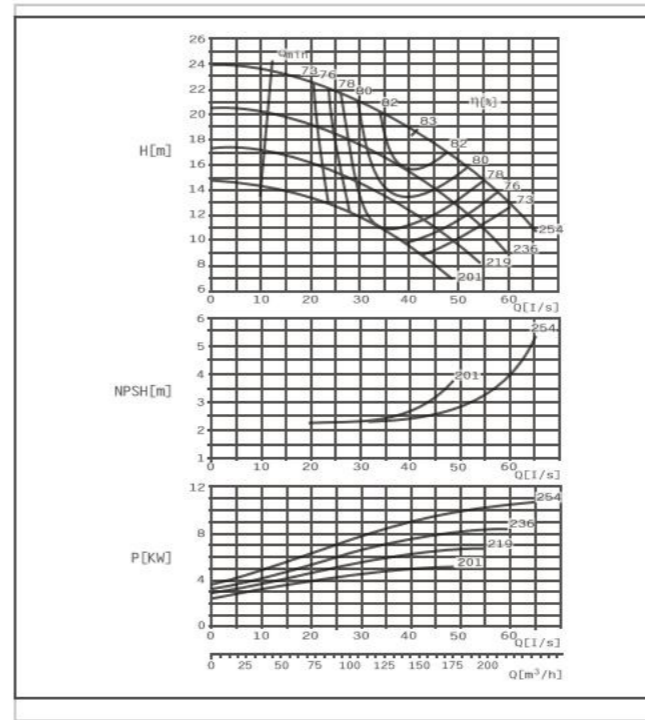

SBS100-250 F Performance Curve n=1450r/min

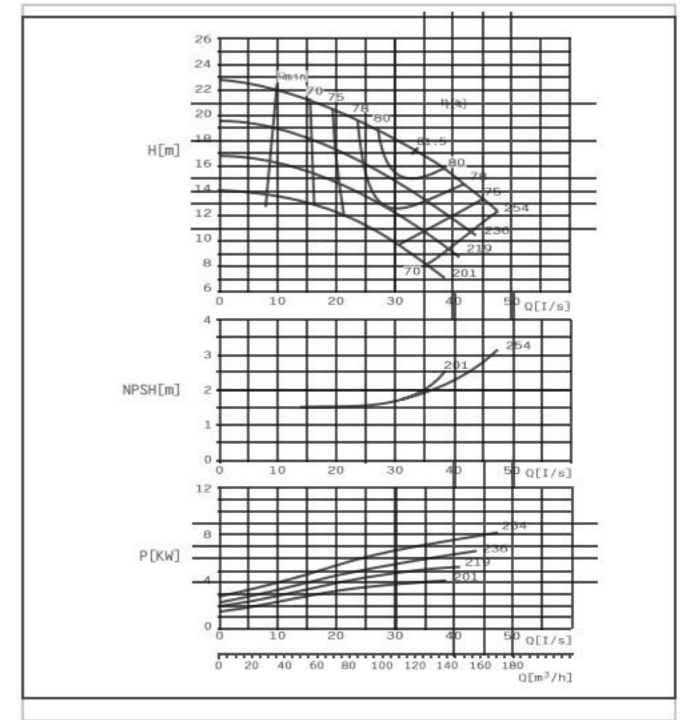

**SBS Horizontal pump installation dimension drawing**

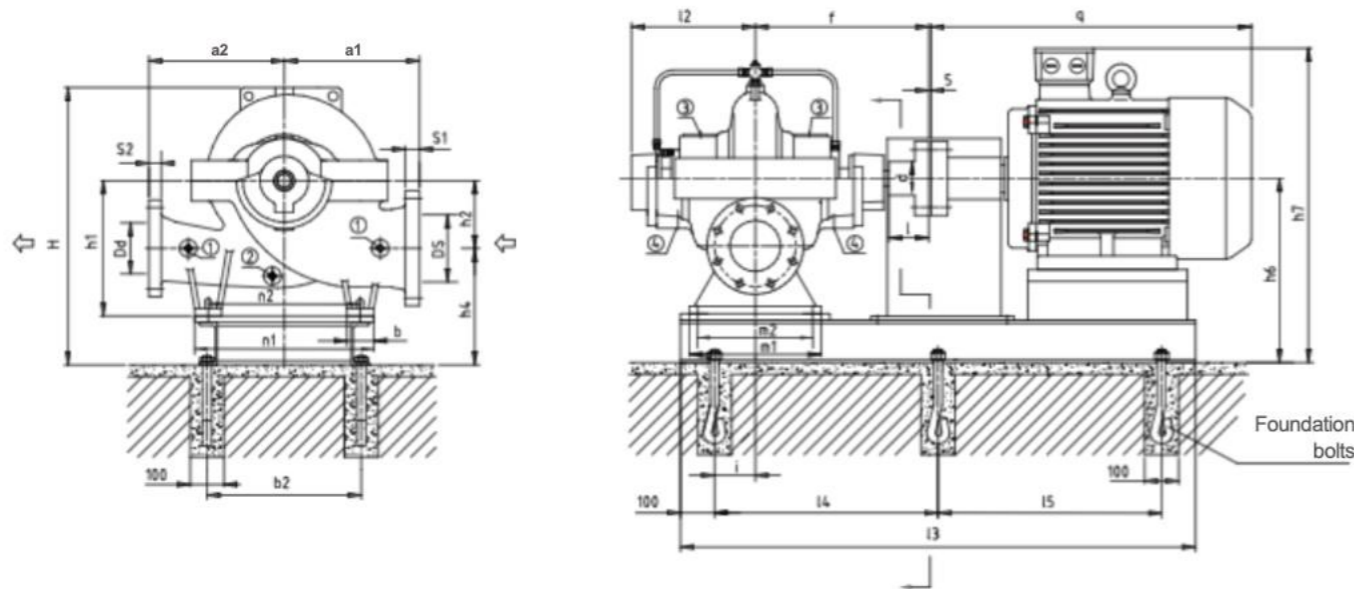

Suction flange



Discharge flange

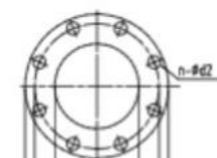

**Connection Dimensions**

- ① Pressure gauge Rp1/2
- ② Drain plug Rp1/2

**Parameter Chart**

Model	Capacity		Head m	Speed r/min	Eff. %	Motor power kW	NPSH m	Impeller diameter mm
	m³/h	L/S						
SBS 80-370E	90	25	41	1450	73	18.5	2.8	345
	113	31.4	38.8		75			
	136	37.8	33.5		71.8			
	80	22.2	35		71			
	99	27.5	33		72.2			
	120	33.3	29.1		71			
SBS 80-370F	70	19.4	29.3	1450	68.4	11	2.3	300
	88	24.4	27.5		70			
	106	29.4	24.7		68.3			
	65	18.1	23.8		66			
	81	22.5	22.5		67.5			
	98	27.2	20		65.5			
SBS 100-250E	115	31.9	21.2	1450	80.7	11	2.9	254
	144	40	18.8		83			
	173	48.1	17.5		81.7			
	112	31	17.5		79			
	140	38.8	15.8		81			
	167	46.5	13.2		77			
SBS 100-250F	100	27.8	14.5	1450	77.8	7.5	2.9	219
	126	35	13.5		79			
	150	41.7	11.9		77.6			
	97	26.8	12.2		75.5			
	120	33.8	11.2		77.5			
	145	40.2	9.5		75.5			
SBS 80-370E	80	22.2	38.8	1450	71	18.5	3	345
	99	27.5	35.5		73			
	120	33.3	31.1		70			
	72	20	34.1		69			
	90	25	30.8		70			
	108	30	26.3		68			
SBS 100-250F	60	16.7	27.5	1450	64.5	11	2.3	295
	76	21.1	25.5		66			
	90	25	22.5		65.2			
	53	14.7	21.3		63			
	67	18.6	20		64			
	80	22.2	17.5		63			

**Parameter Chart**

Model	Capacity		Head m	Speed r/min	Eff. %	Motor power kW	NPSH m	Impeller diameter mm
	m³/h	L/S						
SBS 80-370E	90	25	41	1450	73	18.5	2.8	345
	113	31.4	38.8		75			
	136	37.8	33.5		71.8			
	80	22.2	35		71			
	99	27.5	33		72.2			
	120	33.3	29.1		71			
SBS 100-250E	115	31.9	21.2	1450	80.7	11	2.9	254
	144	40	18.8		83			
	173	48.1	17.5		81.7			
	112	31	17.5		79			
	140	38.8	15.8		81			
	167	46.5	13.2		77			
SBS 80-370F	70	19.4	29.3	1450	68.4	11	2.3	300
	88	24.4	27.5		70			
	106	29.4	24.7		68.3			
	65	18.1	23.8		66			
	81	22.5	22.5		67.5			
	98	27.2	20		65.5			
SBS 100-250F	100	27.8	14.5	1450	77.8	7.5	2.9	219
	126	35	13.5		79			
	150	41.7	11.9		77.6			
	97	26.8	12.2		75.5			
	120	33.8	11.2		77.5			
	145	40.2	9.5		75.5			

**Dimensions**

Model	Suction flange ( mm )					Discharge flange ( mm )					Pump size ( mm )										WGT kg		
	DS	D1	D2	n-φd1	S1	Dd	D3	D4	n-φd2	S2	m1	m2	n1	n2	b	a1	a2	l2	f	h1		h2	H
80-370	125	210	250	8-φ18	31	80	160	200	8-φ18	27	320	270	410	340	70	330	330	310	385	315	140	640	242
100-250	150	240	285	8-φ23	31	100	180	220	8-φ18	29	320	270	470	400	70	330	330	310	385	355	170	665	257

**Installation dimensions**

Model	Motor		b2	h4	h6	h7	l3	l4	l5	i	q	Motor weight (kg)	Baseplate weight (kg)	Coupling φx l	Foudation bolts
	Frame Size	Power (kW)													
80-370	132M	7.5	430	295	435	658	970	385	70	525	88	121	127	Ø39x80	6-M16x350
	160M	11				700	1050	425							
	160L	15				700	1100	450							
	180M	18.5				720	1110	455							
	180L	22				720	1172	475							

SBS100-310 E Performance Curve n=1450r/min

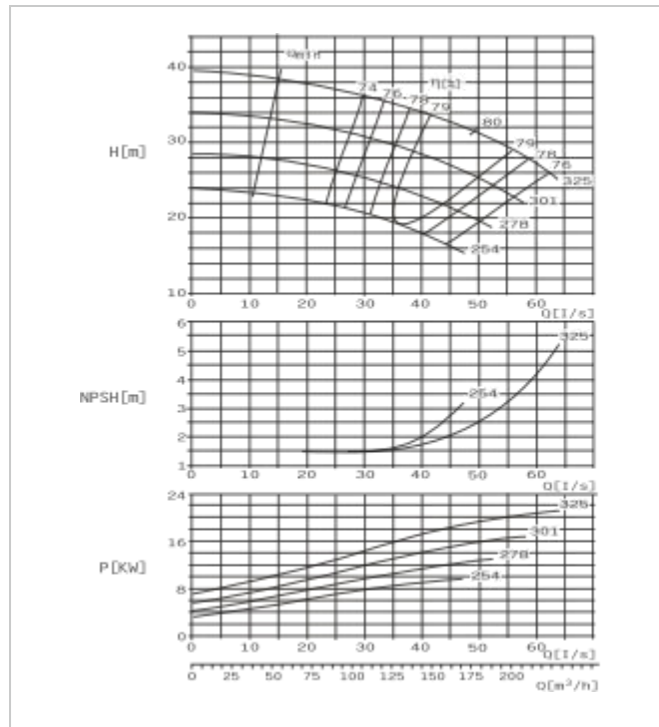

SBS100-310 F Performance Curve n=1450r/min

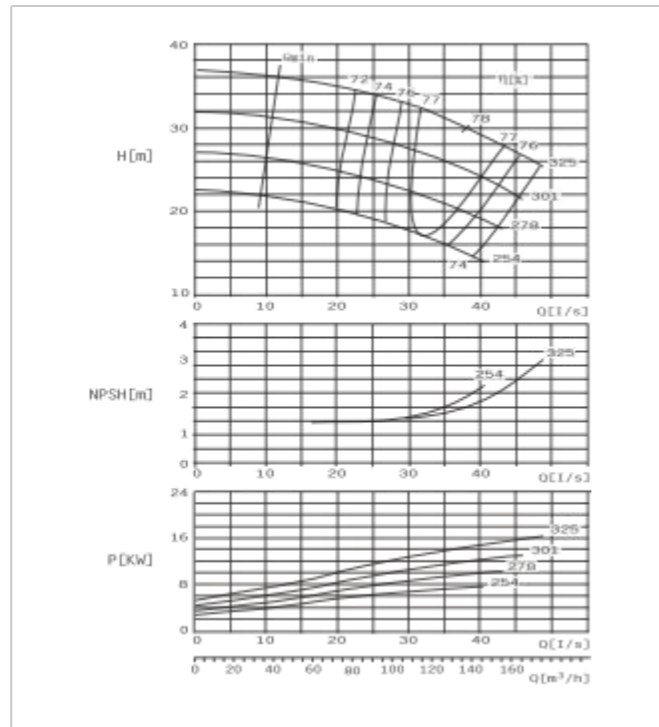

SBS100-375 E Performance Curve n=1450r/min

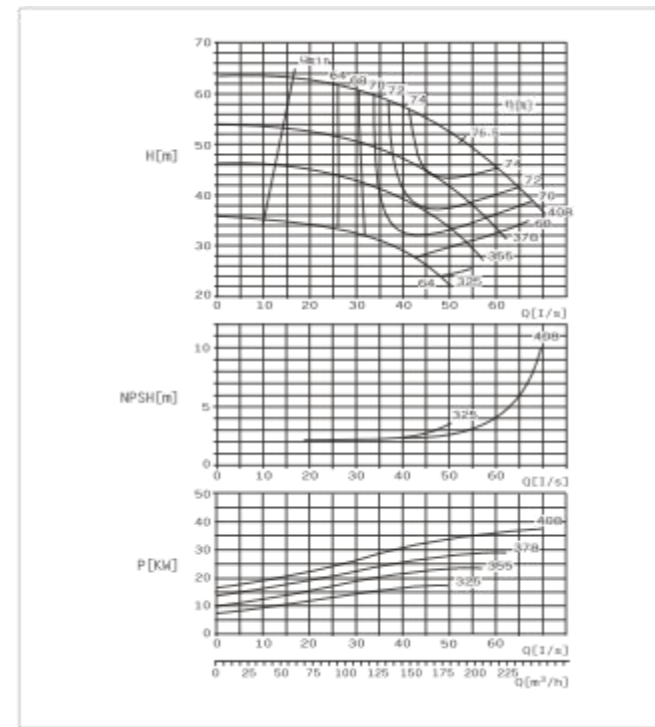

SBS100-375 F Performance Curve n=1450r/min

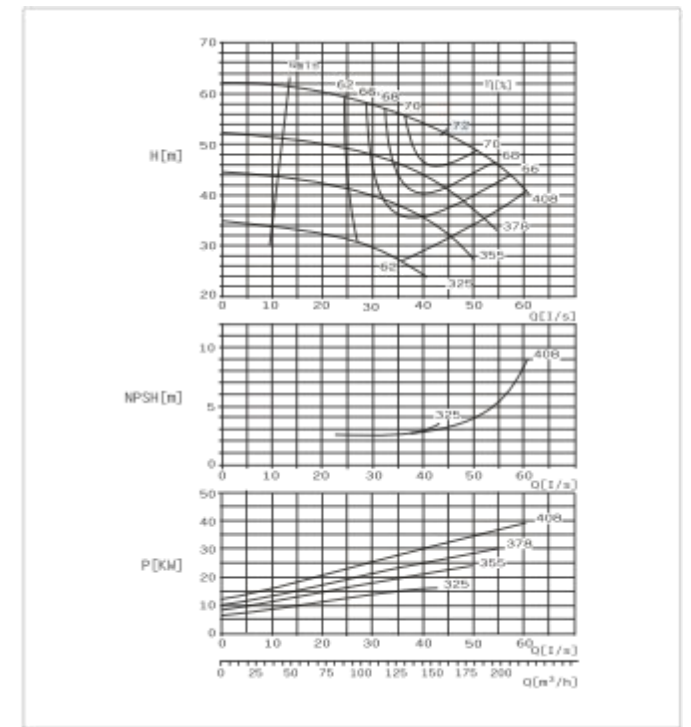

**SBS Horizontal pump installation dimension drawing**

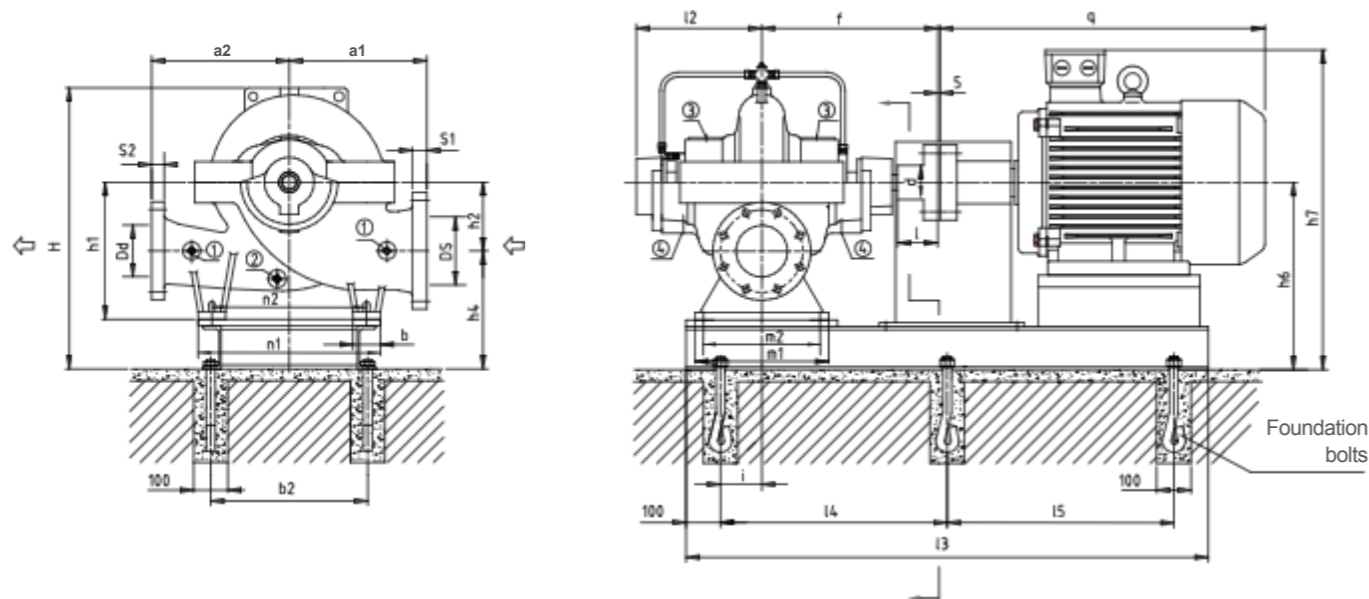

Suction flange

Discharge flange

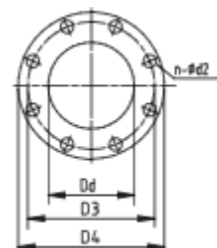
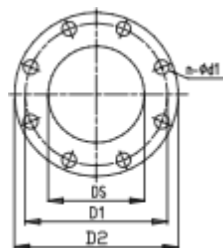

**Connection Dimensions**

- ① Pressure gauge Rp1/2
- ② Drain plug Rp1/2
- ③ Air vent Rp1/2
- ④ Leakage drains hole Rp3/4

**Parameter Chart**

Model	Capacity		Head m	Speed r/min	Eff. %	Motor power kW	NPSH m	Impeller diameter mm		
	m³/h	L/S								
SBS 100-310E	148	41.1	34	1450	78.5	30	3.1	325		
	185	51.3	31		80					
	222	61.7	26.8		77.5					
	133	36.8	29.3		79					
	166	46.1	27		79.6					
	200	55.6	24.3		77.4					
	120	33.3	24.8		78					
	151	41.9	22.5		79.3					
	180	50	20		77.4					
	112	31.2	20.2		77.8					
140	38.9	18.5	79	18.5	2.7	301				
162	44.9	16.2	78							
112	31.2	32.5	76.6				1450	15	2.5	325
140	38.9	29.5	78							
168	46.7	25	74							
106	29.4	27.5	76.6							
133	37	25.5	77.6							
160	44.4	22	75							
100	27.8	23	76.2							
124	34.4	21.2	77.3							
150	41.7	18	75							
94	26.1	19.4	76.5	11	2.4	278				
117	32.5	17	77							
140	38.9	15	76							

**Parameter Chart**

Model	Capacity		Head m	Speed r/min	Eff. %	Motor power kW	NPSH m	Impeller diameter mm		
	m³/h	L/S								
SBS 100-375E	148	41.1	57	1450	73	45	3	408		
	185	51.4	51		76.5					
	220	61.1	44		74					
	133	36.9	47.3		71					
	167	46.4	46		74					
	200	55.6	38		72.3					
	124	34.4	41		67.5					
	155	43.1	38		71					
	186	51.7	31		68					
	108	30	32.5		66.3					
135	37.5	30.3	69	18.5	2.1	325				
162	45	25.3	66.5							
130	36.1	56.2	70				1450	37	3.6	408
162	45	52	72							
195	54.2	45.8	67.5							
114	31.7	47.5	66.5							
142	39.4	44	69							
170	47.2	39	66.5							
105	29.2	40	64.5							
130	36.1	37.5	66.5							
157	43.6	32.5	64							
92	25.6	30.8	61	11	18.5	2.7				
115	31.9	28.7	63							
138	38.3	25	61.2							

**Dimensions**

Model	Suction flange ( mm )					Discharge flange ( mm )					Pump size ( mm )										WG		
	DS	D1	D2	n-φd1	S1	Dd	D3	D4	n-φd2	S2	m1	m2	n1	n2	b	a1	a2	l2	f	h1		h2	H
100-310	150	240	285	8-φ23	31	100	180	220	8-φ18	29	320	270	470	400	70	330	330	310	385	355	170	680	262
100-375	150	240	285	8-φ23	31	100	180	220	8-φ18	29	320	270	470	400	70	370	370	310	385	355	170	735	270

**Installation dimensions**

Model	Motor		b2	h4	h6	h7	l3	l4	l5	i	q	Motor weight (kg)	Baseplate weight (kg)	Coupling d×l	Foundation bolts
	Frame Size	Power (kW)													
100-375	100-310	160M	11	500	305	475	740	1060	430	70	665	132	138	φ39×80	6-M20×400
		160L	15				740	1100	450		665	150	138		
		180M	18.5				760	1100	450		730	190	139		
		180L	22				760	1140	470		730	206	142		
		200L	30				785	1190	495		790	278	144		
		225S	37				810	1220	510		840	330	146		
		225M	45				810	1240	520		865	360	148		

SBS125-230 E Performance Curve n=1450r/min

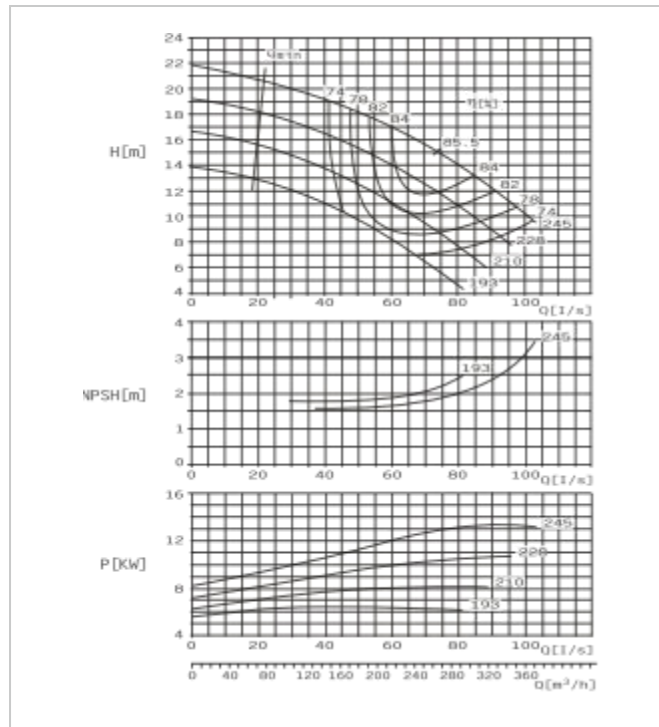

SBS125-230 F Performance Curve n=1450r/min

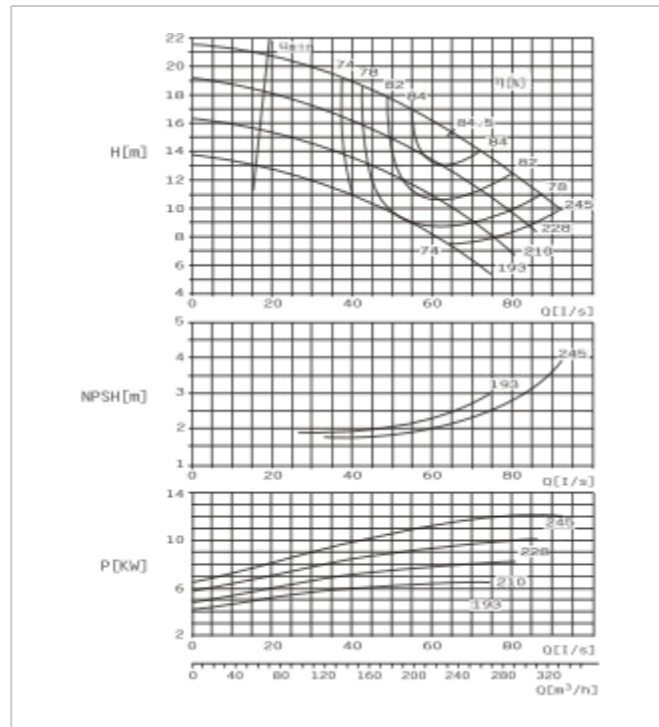

SBS125-290 E Performance Curve n=1450r/min

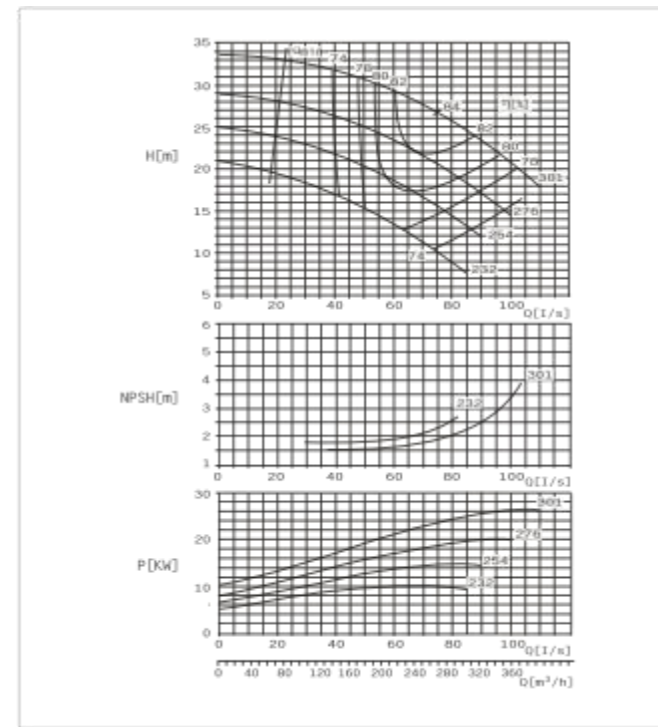

SBS125-290 F Performance Curve n=1450r/min

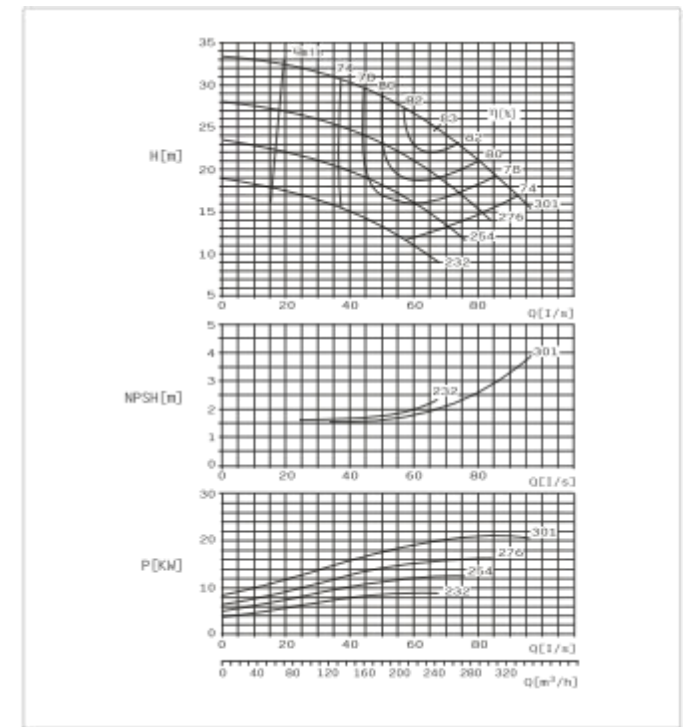

**SBS Horizontal pump installation dimension drawing**

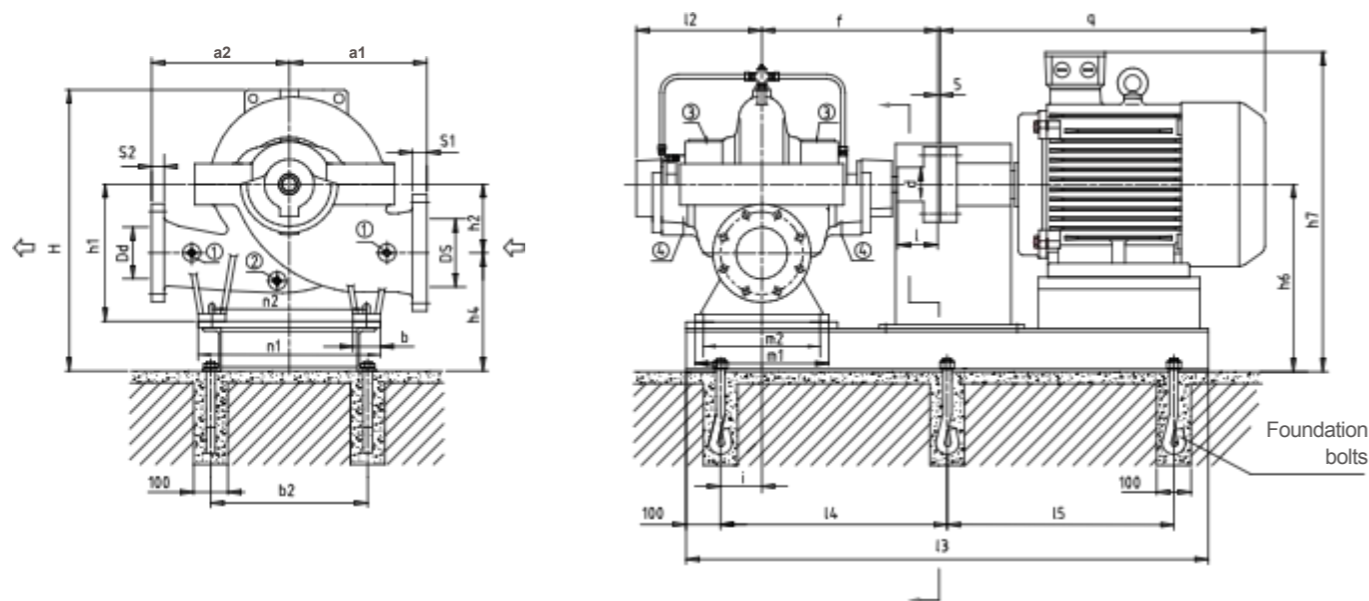

Suction flange

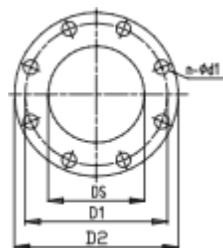

Discharge flange

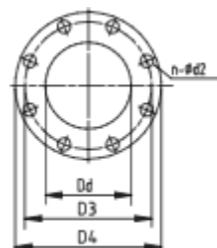

**Connection Dimensions**

- ① Pressure gauge Rp1/2
- ② Drain plug Rp1/2
- ③ Air vent Rp1/2
- ④ Leakage drains hole Rp3/4

**Parameter Chart**

Model	Capacity		Head m	Speed r/min	Eff. %	Motor power kW	NPSH m	Impeller diameter mm
	m³/h	L/S						
SBS 125-230E	220	61.1	17	1450	84	15	2.3	245
	274	76.1	14.8		85.5			
	328	91.1	12		82			
	193	53.6	15		81	15	2.3	228
	241	66.9	13.2		84.5			
	290	80.5	10.8		82			
	184	51.1	12.6		79.4	11	2.2	210
	230	63.9	10.6		82.5			
	277	76.9	8		76			
	167	46.4	10.3		73	7.5	2.2	193
209	58.1	8.7	77.5					
250	69.4	6.8	73					
190	52.8	17	84.1	15	2.7			
238	66.1	15.1	84.5					
307	85.3	11.5	80					
SBS 125-230F	170	47.2	15.4	1450	81	11	2.7	228
	212	58.9	13.5		84			
	255	70.8	11.4		82			
	164	45.6	13		78	11	2.7	210
	205	56.9	11.5		82			
	246	68.4	9.2		78			
	156	43.2	10.5		75	7.5	2.7	193
	195	54.2	9.1		78			
	223	61.9	7.7		74			

**Parameter Chart**

Model	Capacity		Head m	Speed r/min	Eff. %	Motor power kW	NPSH m	Impeller diameter mm
	m³/h	L/S						
SBS 125-290E	215	59.7	29.2	1450	82.3	30	2.4	301
	269	74.7	27		84			
	323	89.7	23.5		82			
	195	54.2	24.4		80.3	22	2.4	276
	243	67.5	22		80			
	292	81.1	19.6		80			
	178	49.4	20		79	15/18.5	2.3	254
	223	61.9	18		80			
	268	74.4	15.5		78.3			
	161	44.7	16.3		77	15	2.3	232
202	56.1	14.2	78					
242	67.2	11.8	76.2					
193	53.6	27.5	81	22	2.4			
241	66.9	25	83					
290	80.6	21.3	80					
SBS 125-290F	174	48.3	23.4	1450	80	18.5	2.3	276
	218	60.6	21		82			
	261	72.5	17.5		78			
	157	43.6	19		78	15	2.2	254
	196	54.4	17.5		79			
	235	55.3	15		78			
	138	38.3	15.1		74.3	11	2.2	232
	173	48.1	13.7		76			
	207	57.5	11.3		74			

**Dimensions**

Model	Suction flange ( mm )					Discharge flange ( mm )					Pump size ( mm )										WGT kg		
	DS	D1	D2	n-φd1	S1	Dd	D3	D4	n-φd2	S2	m1	m2	n1	n2	b	a1	a2	l2	f	h1		h2	H
125-230	200	295	340	12-φ23	35	125	210	250	8-φ18	31	390	340	530	450	80	370	370	370	515	400	200	710	350
125-290	200	295	340	12-φ23	35	125	210	250	8-φ18	31	390	340	530	450	80	370	370	370	515	400	200	730	360

**Installation dimensions**

Model	Motor		b2	h4	h6	h7	l3	l4	l5	i	q	Motor weight (kg)	Baseplate weight (kg)	Coupling d×l	Foudation bolts
	Frame Size	Power (kW)													
125-290	132M	7.5	560	320	520	743	1100	450	105	105	525	88	151	φ44×100	6-M20×400
	160M	11				785	1190	495			665	132	159		
	160L	15				785	1240	520			665	150	162		
	180M	18.5				805	1240	520			730	190	162		
	180L	22				805	1338	540			730	206	165		
	200L	30				865	1320	560			790	278	166		
	225S	37				890	1400	600			840	330	168		

SBS125-365 E Performance Curve n=1450r/min

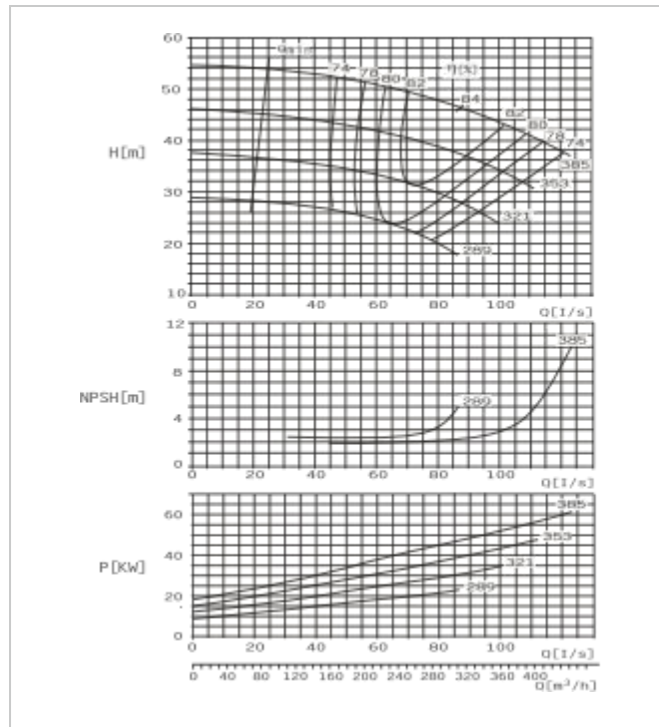

SBS125-365 F Performance Curve n=1450r/min

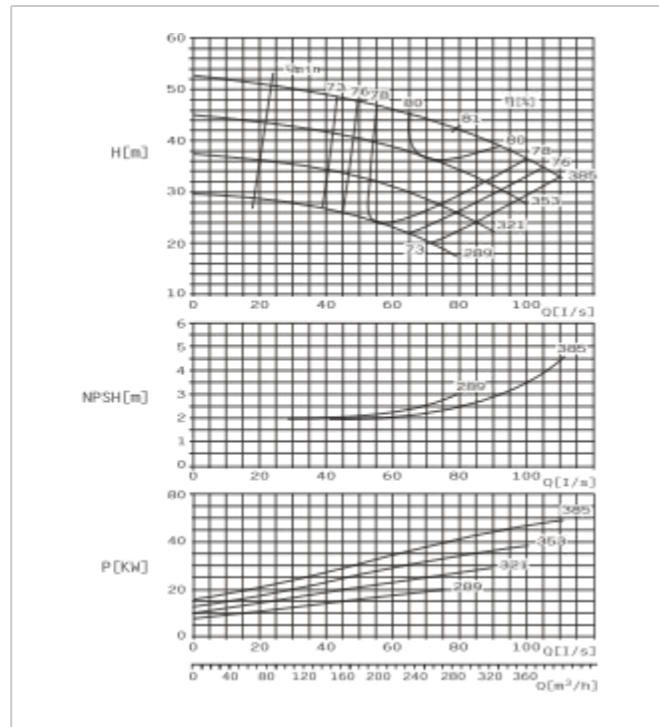

SBS125-500 E Performance Curve n=1450r/min

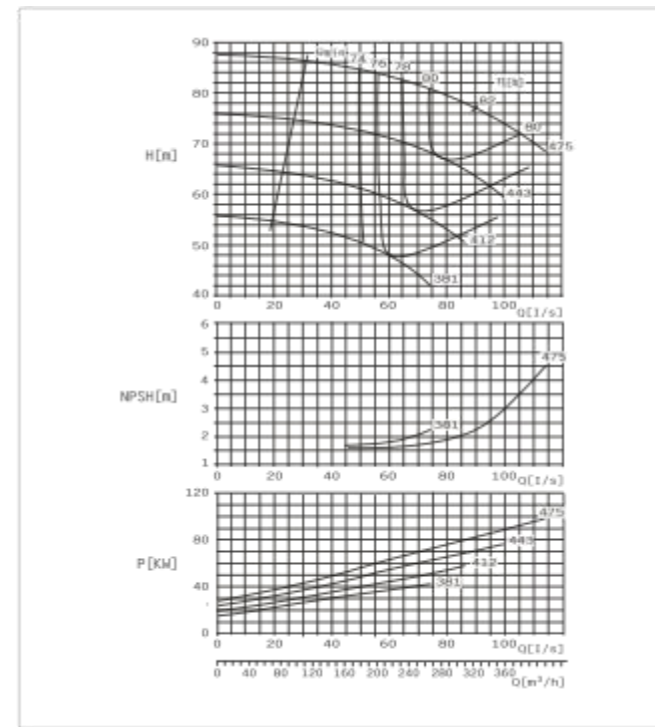

SBS125-500 F Performance Curve n=1450r/min

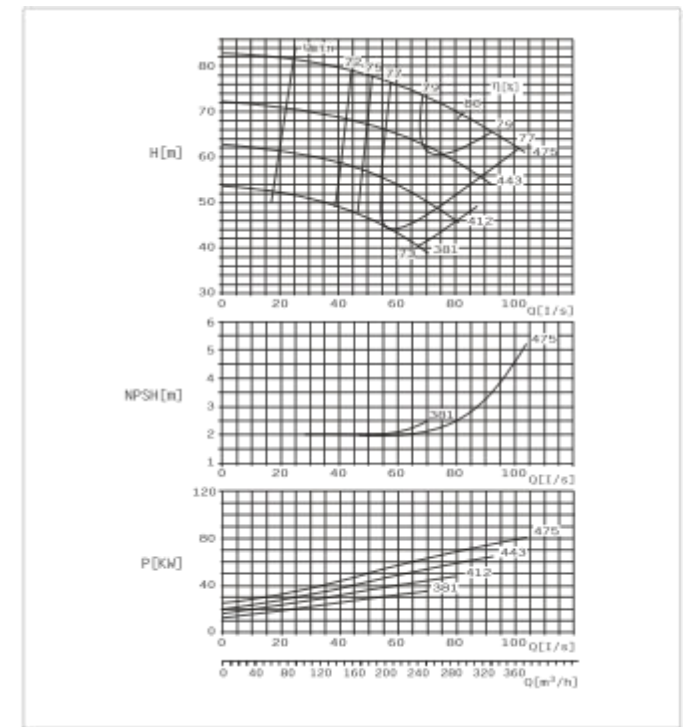

SBS Horizontal pump installation dimension drawing

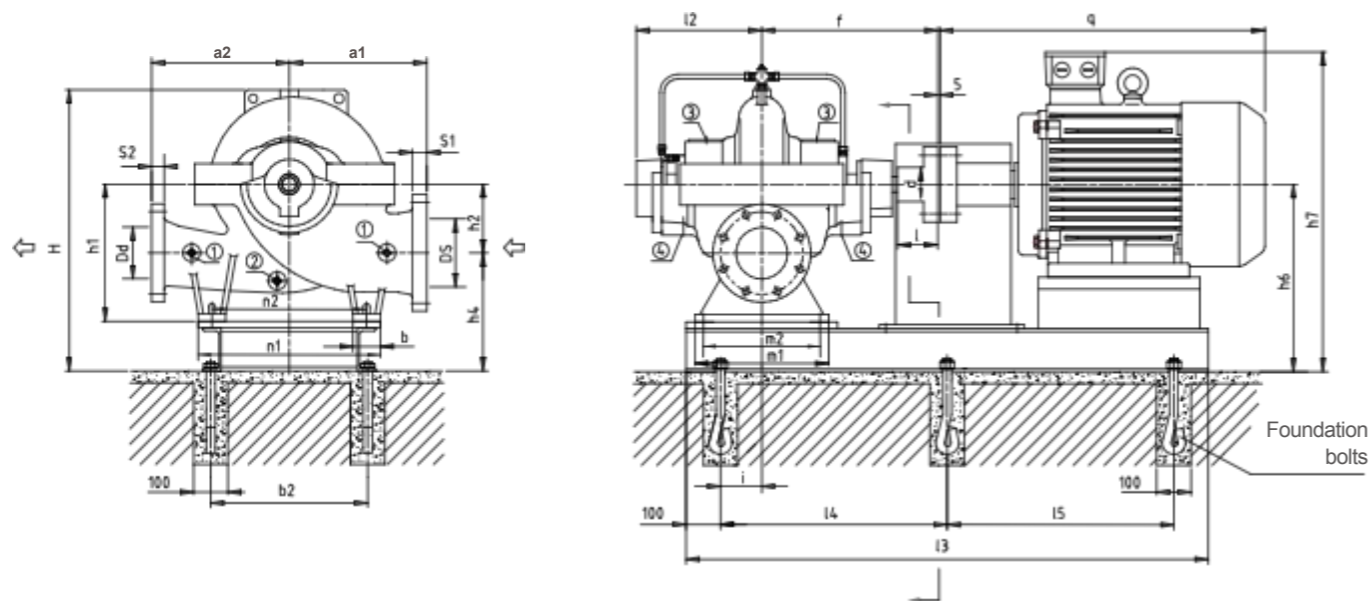

Suction flange

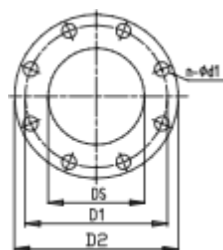

Discharge flange

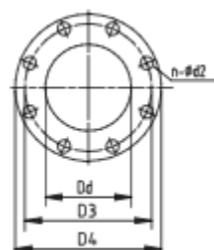

Connection Dimensions

- ① Pressure gauge Rp1/2
- ② Drain plug Rp1/2
- ③ Air vent Rp1/2
- ④ Leakage drains hole Rp3/4

Parameter Chart

Model	Capacity		Head m	Speed r/min	Eff. %	Motor power kW	NPSH m	Impeller diameter mm
	m³/h	L/S						
SBS 125-365E	245	68.8	50	1450	82	55	2.6	385
	310	86	47		84			
	360	100	44		82			
	225	62.4	41.6		80	45	2.8	353
	281	78	39		83			
	337	93.6	35.6		81.2			
	205	56.8	33.7		76			
256	71	31.5	82	37	2.9	321		
307	85.2	28.2	79.5					
184	51.2	25.5	76					
230	64	24	80	22/30	3	289		
278	76.8	20.9	78					
222	61.6	46.3	79.2					
277	77	43	81	55	2.9	385		
333	92.4	38.8	80					
202	56	39.8	78.5					
252	70	37	80	37	2.8	353		
302	84	32.8	79					
182	50.4	32.6	76.5					
227	63	30.5	78.5	30	2.8	321		
272	75.6	27.5	76					
158	44	26.3	77.8					
198	55	24.5	78	22	2.7	289		
238	66	21.8	75.2					

Parameter Chart

Model	Capacity		Head m	Speed r/min	Eff. %	Motor power kW	NPSH m	Impeller diameter mm
	m³/h	L/S						
SBS 125-500E	262	72.8	82	1450	79.5	110	2.8	475
	328	86	76		82			
	393	109.2	70		77.8			
	233	64.8	70		80	90	2.7	443
	292	81	66.5		80			
	342	95	62		77.2			
	205	56.8	60		76			
256	71	56	77	75	2.5	412		
307	85.2	51.5	76					
184	51.2	50	73.5					
230	64	47	76.5	45	2.5	381		
252	70	45	76					
235	65.2	75	77.7					
293	81.5	69.5	79	90	3.2	475		
352	97.8	63	77					
217	60.4	65	76.8					
272	75.5	60.5	78	75	2.9	443		
326	90.6	55	76					
181	50.4	57	75.1					
227	63	53	77	55	2.6	412		
272	75.6	48.3	75.8					
161	44.8	47.5	74					
202	56	45	76	37	2.5	381		
234	65	40	74					

Dimensions

Model	Suction flange ( mm )				Discharge flange ( mm )				Pump size ( mm )										WGT kg				
	DS	D1	D2	n-φd1	S1	Dd	D3	D4	n-φd2	S2	m1	m2	n1	n2	b	a1	a2	l2		f	h1	h2	H
125-365	200	295	340	12-φ23	35	125	210	250	8-φ18	31	390	340	530	450	80	370	370	370	515	400	200	770	383
125-500	200	295	340	12-φ23	35	125	210	250	8-φ18	31	390	340	630	560	70	450	450	370	515	400	200	805	429

Installation dimensions

Model	Motor		b2	h4	h6	h7	l3	l4	l5	i	q	Motor weight (kg)	Baseplate weight (kg)	Coupling d×l	Foudation bolts
	Frame Size	Power (kW)													
125-365	180L	22	560	320	520	805	1290	540	105	730	206	164	165	φ44×100	6-M20×400
	200L	30													
	225S	37													
	225M	45													
	250M	55													
	280S	75													
	225S	37													
125-500	225M	45	670	320	520	855	1380	590	105	840	330	165	176	φ44×100	6-M20×400
	250M	55													
	280S	75													
	280M	90													
	315S	110													
	225M	45													
	250M	55													
280S	75														
280M	90														
315S	110														

SBS150-290 E Performance Curve n=1450r/min

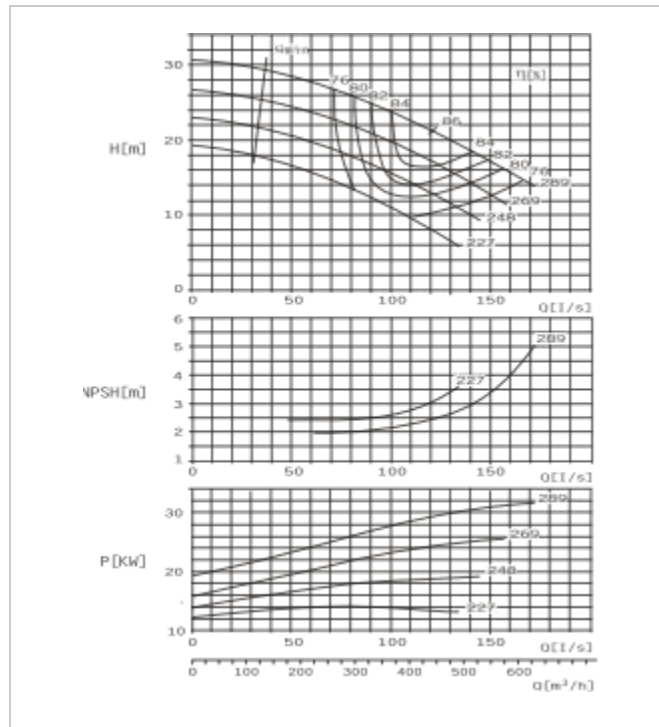

SBS150-290 F Performance Curve n=1450r/min

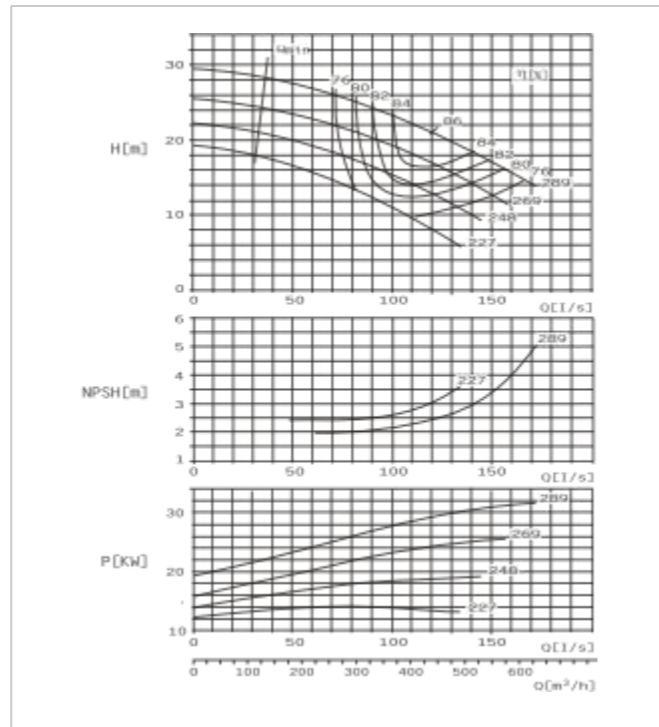

SBS150-360 E Performance Curve n=1450r/min

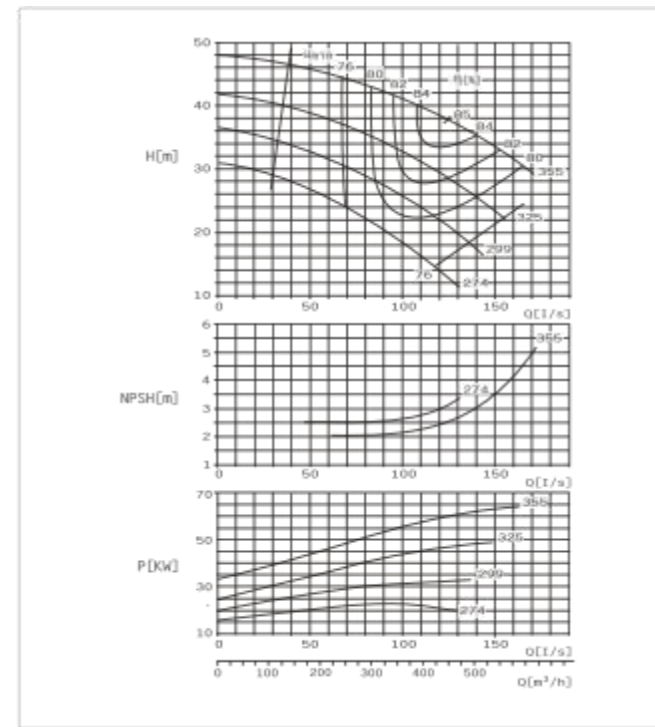

SBS150-360 F Performance Curve n=1450r/min

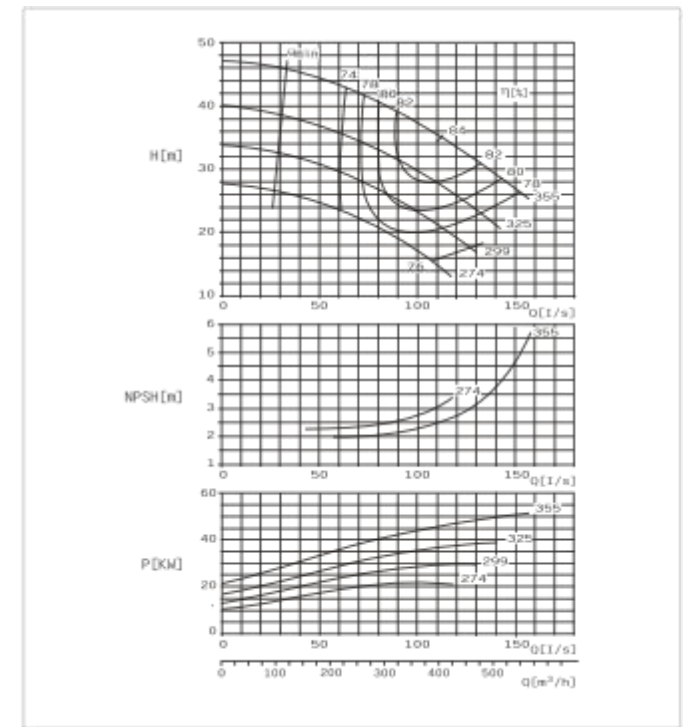

**SBS Horizontal pump installation dimension drawing**

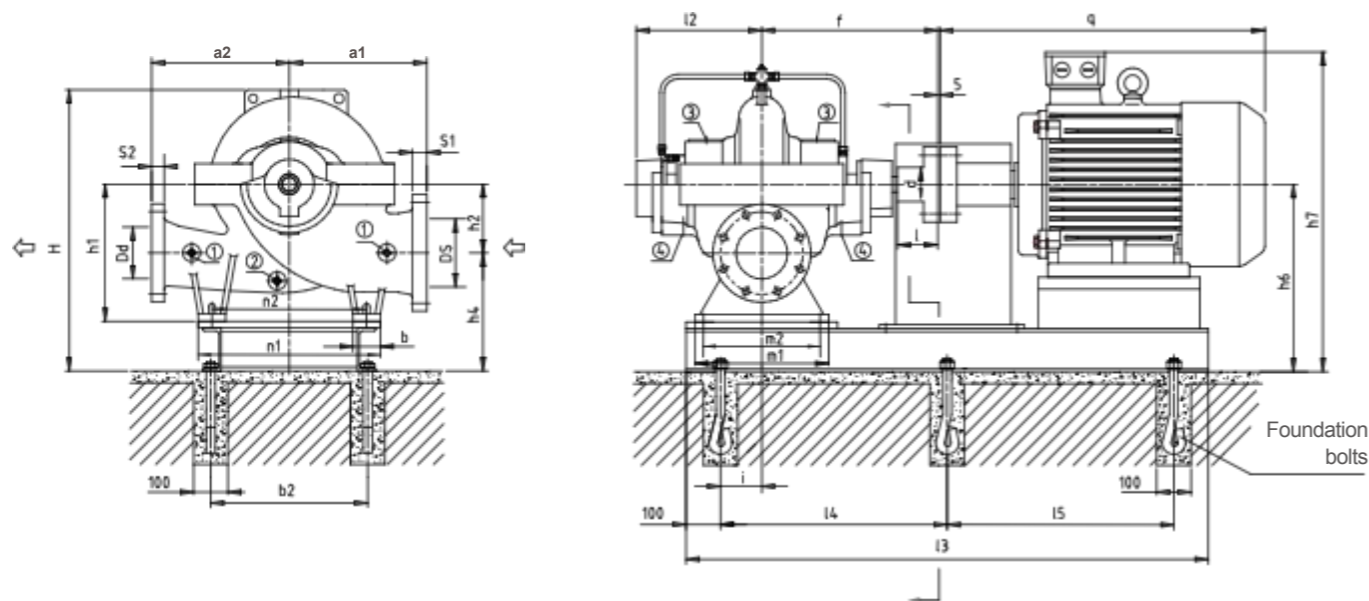

Suction flange

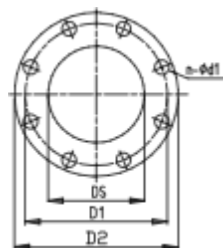

Discharge flange

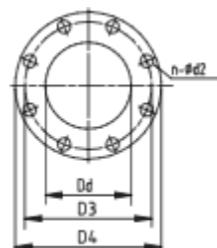

**Connection Dimensions**

- ① Pressure gauge Rp1/2
- ② Drain plug Rp1/2
- ③ Air vent Rp1/2
- ④ Leakage drains hole Rp3/4

**Parameter Chart**

Model	Capacity		Head m	Speed r/min	Eff. %	Motor power kW	NPSH m	Impeller diameter mm
	m³/h	L/S						
SBS 150-290E	354	98.3	24	1450	85.6	37	2.9	289
	443	123	21		87			
	531	147.5	17.5		83.5			
	323	89.7	21		83			
	403	112	18		86			
	484	134.4	15		82.3			
	302	83.9	17.5		80			
	378	105	15		84			
	454	126	12.3		79.4			
	280	77.8	13.7		75			
SBS 150-290F	317	88	23.4	1450	84.2	30	3	289
	396	110	20.4		86			
	475	132	16.6		83.5			
	302	84	20		82.8			
	378	105	17		85			
	454	126	13.7		82			
	282	78.3	17.5		80.6			
	353	98	14.5		84			
	423	117.5	11.3		79			
	265	73.6	14		76.7			
SBS 150-360E	354	98.3	24	1450	85.6	37	2.9	289
	446	124	38		87			
	536	148.9	34.2		82.7			
	323	89.7	34.2		81.5			
SBS 150-360F	403	112	31	1450	83	55	3	325
	484	134.4	26.3		80.8			
	298	82.8	28.7		79			
	370	102.8	25		81			
	445	123.6	21		78.8			
	265	73.6	23.4		76.5			
	331	92	20		77.6			
	389	110.6	16.7		77.8			
	325	90.3	39.2		82.1			
	407	113	35		84			
488	135.6	30	81					
SBS 150-360E	354	98.3	24	1450	85.6	37	2.9	289
	446	124	38		87			
	536	148.9	34.2		82.7			
	323	89.7	34.2		81.5			
	403	112	31		83			
	484	134.4	26.3		80.8			
	298	82.8	28.7		79			
	370	102.8	25		81			
	445	123.6	21		78.8			
	265	73.6	23.4		76.5			
SBS 150-360F	403	112	31	1450	83	55	3	325
	484	134.4	26.3		80.8			
	298	82.8	28.7		79			
	370	102.8	25		81			
	445	123.6	21		78.8			
	265	73.6	23.4		76.5			
	331	92	20		77.6			
	389	110.6	16.7		77.8			
	325	90.3	39.2		82.1			
	407	113	35		84			
488	135.6	30	81					

**Parameter Chart**

Model	Capacity		Head m	Speed r/min	Eff. %	Motor power kW	NPSH m	Impeller diameter mm
	m³/h	L/S						
SBS 150-290E	354	98.3	24	1450	85.6	37	2.9	289
	446	124	38		87			
	536	148.9	34.2		82.7			
	323	89.7	34.2		81.5			
	403	112	31		83			
	484	134.4	26.3		80.8			
	298	82.8	28.7		79			
	370	102.8	25		81			
	445	123.6	21		78.8			
	265	73.6	23.4		76.5			
SBS 150-290F	317	88	23.4	1450	84.2	30	3	289
	396	110	20.4		86			
	475	132	16.6		83.5			
	302	84	20		82.8			
	378	105	17		85			
	454	126	13.7		82			
	282	78.3	17.5		80.6			
	353	98	14.5		84			
	423	117.5	11.3		79			
	265	73.6	14		76.7			
SBS 150-360E	354	98.3	24	1450	85.6	37	2.9	289
	446	124	38		87			
	536	148.9	34.2		82.7			
	323	89.7	34.2		81.5			
SBS 150-360F	403	112	31	1450	83	55	3	325
	484	134.4	26.3		80.8			
	298	82.8	28.7		79			
	370	102.8	25		81			
	445	123.6	21		78.8			
	265	73.6	23.4		76.5			
	331	92	20		77.6			
	389	110.6	16.7		77.8			
	325	90.3	39.2		82.1			
	407	113	35		84			
488	135.6	30	81					

**Dimensions**

Model	Suction flange ( mm )					Discharge flange ( mm )					Pump size ( mm )								WGT kg				
	DS	D1	D2	n-φd1	S1	Dd	D3	D4	n-φd2	S2	m1	m2	n1	n2	b	a1	a2	l2		f	h1	h2	H
150-290	200	295	340	12-φ23	35	150	240	285	8-φ23	31	390	340	530	450	80	400	400	370	515	400	200	775	370
150-360	200	295	340	12-φ23	35	150	240	285	8-φ23	31	390	340	530	450	80	400	400	370	515	400	200	775	374

**Installation dimensions**

Model	Motor		b2	h4	h6	h7	l3	l4	l5	i	q	Motor weight (kg)	Baseplate weight (kg)	Coupling d×l	Foudation bolts
	Frame Size	Power (kW)													
150-360	160L	15	560	320	520	785	1240	520		105	665	150	162	φ44×100	6-M20×400
	180M	18.5													
	180L	22													
	200L	30													
	225S	37													
	225M	45													
	250M	55													
	280S	75													

SBS150-460 E Performance Curve n=1450r/min

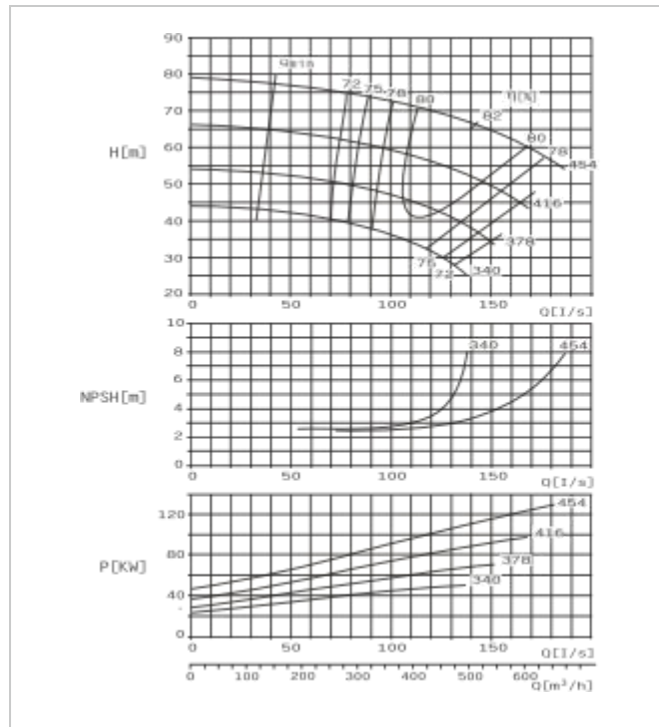

SBS150-460 F Performance Curve n=1450r/min

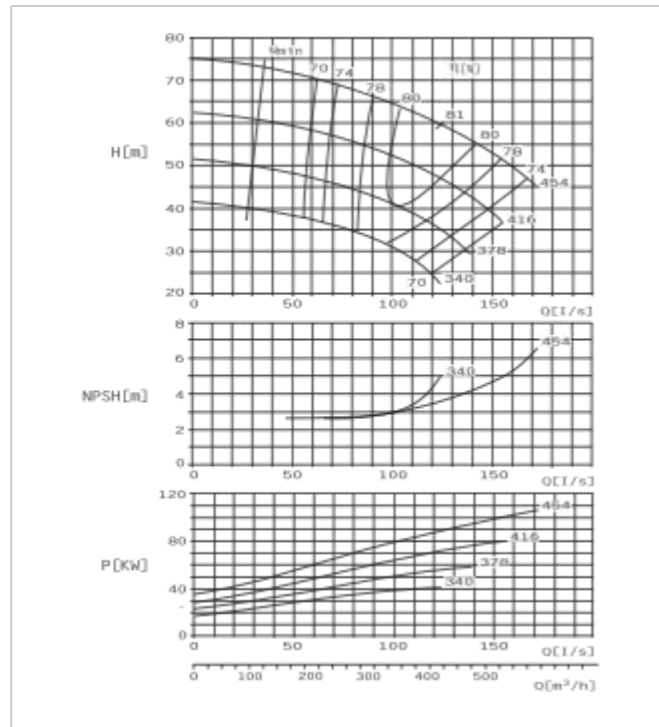

SBS150-605 E Performance Curve n=1450r/min

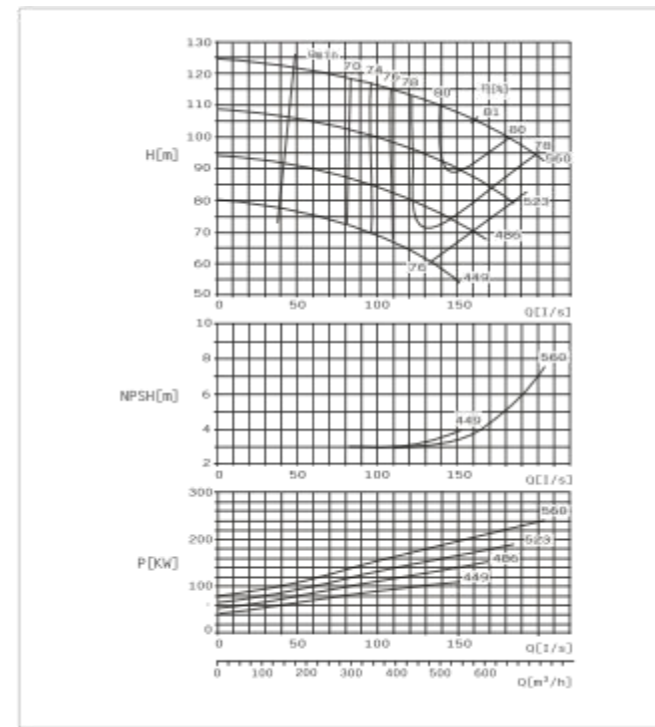

SBS150-605 F Performance Curve n=1450r/min

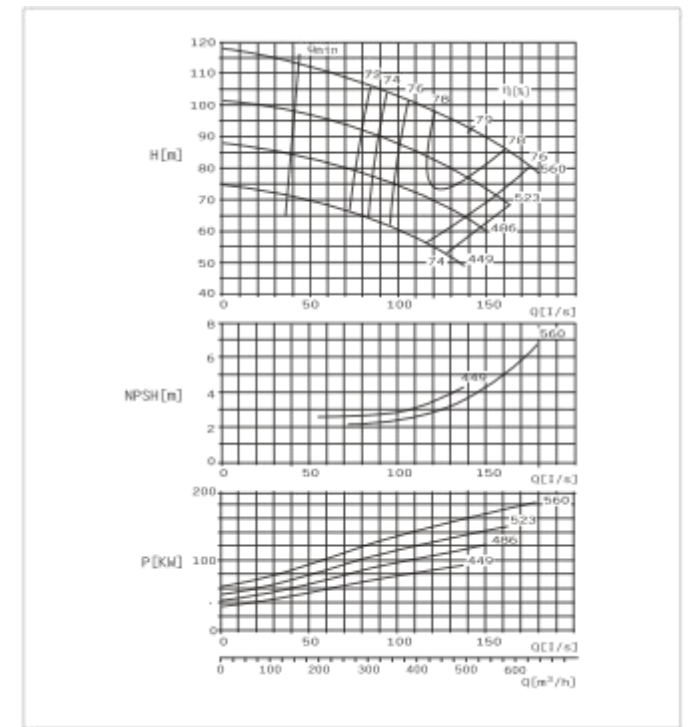

**SBS Horizontal pump installation dimension drawing**

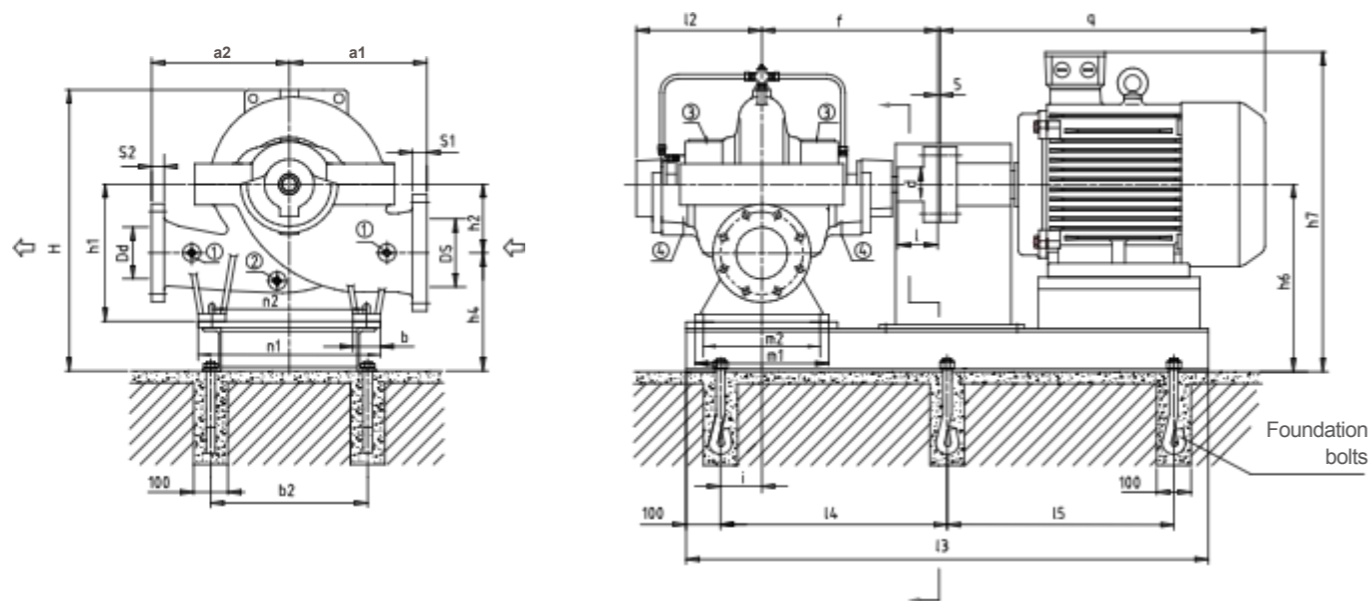

Suction flange

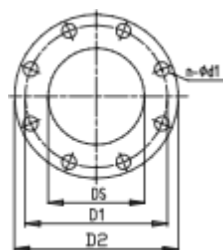

Discharge flange

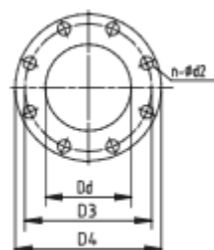

**Connection Dimensions**

- ① Pressure gauge Rp1/2
- ② Drain plug Rp1/2
- ③ Air vent Rp1/2
- ④ Leakage drains hole Rp3/4

**Parameter Chart**

Model	Capacity		Head m	Speed r/min	Eff. %	Motor power kW	NPSH m	Impeller diameter mm
	m³/h	L/S						
SBS 150-460E	412	114.4	71	1450	80.2	132	3.9	454
	515	143.1	66		82			
	618	171.6	60		80			
	377	104.7	58		79.3			
	472	131.1	54.5		81			
	566	157.2	48		78			
	346	96	47.5		78.5			
	432	120	43.5		80			
	516	143.3	37		75			
	317	88	38		77			
396	110	35	78.5					
475	132	28.2	72					
SBS 150-460F	350	97.2	65	1450	79.5	110	3.9	454
	440	122.2	60		78.7			
	527	146.4	53.5		80.5			
	323	89.7	54		78			
	403	112	50		80.5			
	484	134.4	44.5		78			
	300	83.3	44.4		78			
	375	104	40		80			
	450	125	34.5		74			
	260	72.2	35.5		74.8			
324	90	33	78					
390	108	28.4	74					

**Parameter Chart**

Model	Capacity		Head m	Speed r/min	Eff. %	Motor power kW	NPSH m	Impeller diameter mm
	m³/h	L/S						
SBS 150-605E	467	129.7	112	1450	78	250	4.2	560
	583	161.9	105		81			
	700	194.4	95.5		78			
	440	122.2	96		76.3			
	550	152.7	88.5		79			
	648	180	81		76.3			
	412	114.4	82		76.6			
	515	143	75		78			
	605	168	68		74			
	378	105	67.5		75.2			
472	131.1	61.5	77					
526	146.1	55.2	74					
SBS 150-605F	430	119.4	98	1450	76.8	200	4.7	560
	536	148.9	90		79			
	617	171.4	82		76			
	392	108.9	85		76.3			
	490	136.1	78		78			
	576	160	70		74.2			
	357	99.2	75		75.9			
	446	124	68.5		77			
	535	148.8	60		74			
	323	89.7	62.5		74.9			
403	112	57.5	76					
484	134.4	50	72					

**Dimensions**

Model	Suction flange ( mm )					Discharge flange ( mm )					Pump size ( mm )										WGT kg		
	DS	D1	D2	n-φd1	S1	Dd	D3	D4	n-φd2	S2	m1	m2	n1	n2	b	a1	a2	l2	f	h1		h2	H
150-460	200	295	340	12-φ23	35	150	240	285	8-φ23	31	480	430	630	560	70	450	450	430	590	400	200	805	505
150-605	200	295	340	12-φ23	35	150	240	285	8-φ23	31	480	430	770	700	70	600	500	430	590	500	300	970	655

**Installation dimensions**

Model	Motor		b2	h4	h6	h7	l3	l4	l5	i	q	Motor weight (kg)	Baseplate weight (kg)	Coupling d×l	Foudation bolts
	Frame Size	Power (kW)													
150-460	225M	45	670	340	540	875	1500	650	150	150	865	360	185	φ54×110	6-M20×400
	250M	55													
	280S	75													
	280M	90													
	315S	110													
	315M	132													
	315L	160													
	315S	110													
	315M	132													
	315L	160-200													
150-605	355M	220-250	820	380	680	1170	1800	800	150	150	1650	1725	350	φ54×110	6-M20×400
	315M	132													
	315L	160-200													
	355M	220-250													

SBS200-320 E Performance Curve n=1450r/min

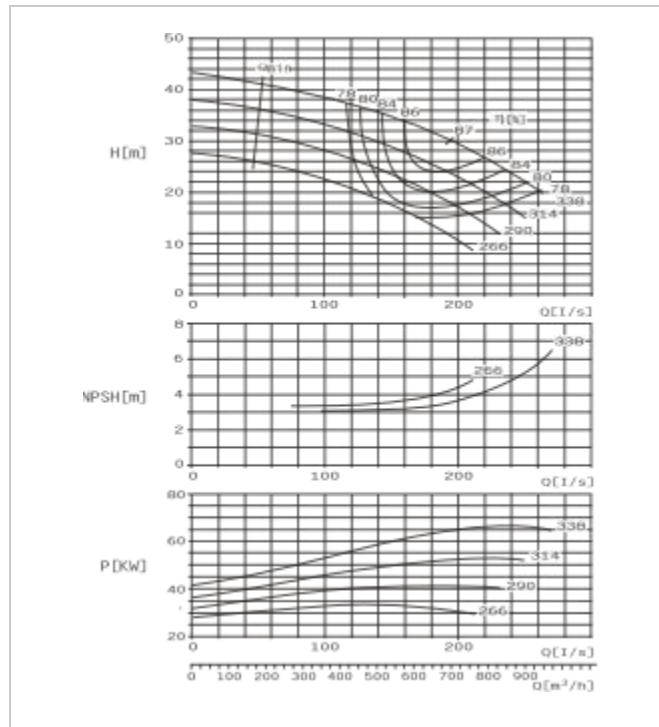

SBS200-320 F Performance Curve n=1450r/min

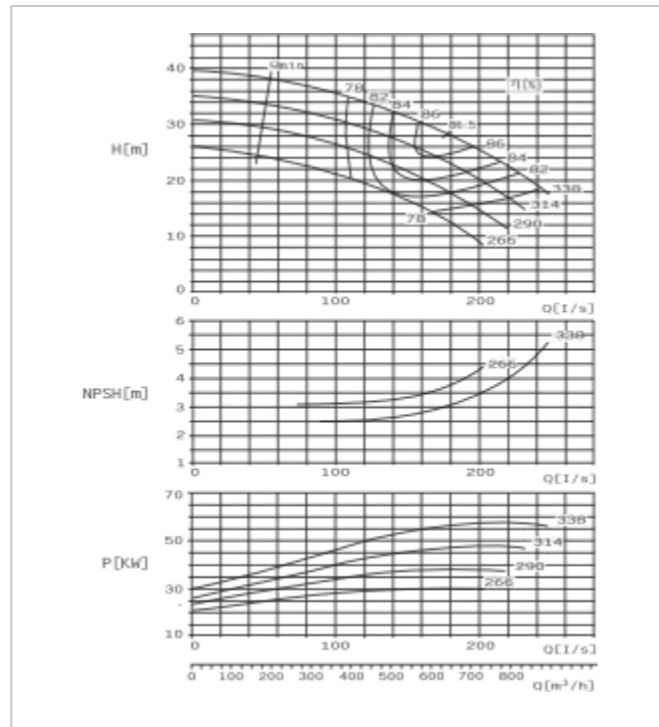

SBS200-420 E Performance Curve n=1450r/min

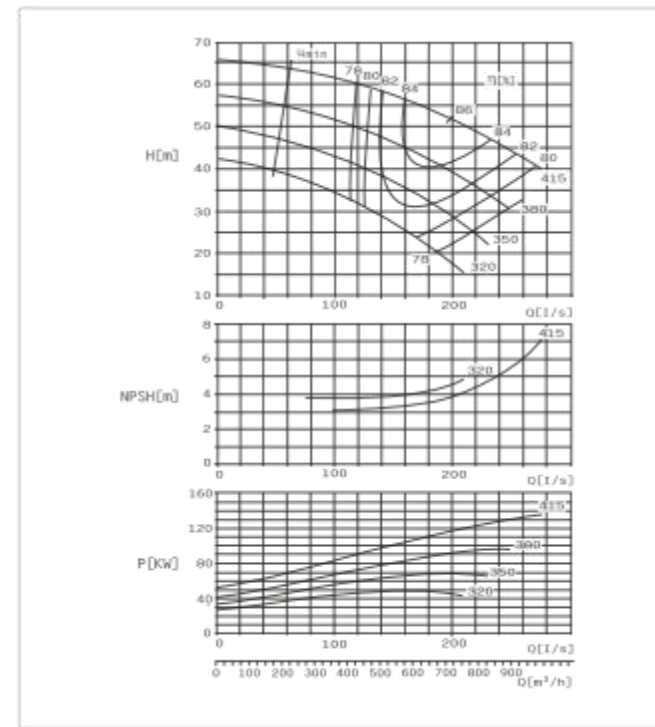

SBS200-420 F Performance Curve n=1450r/min

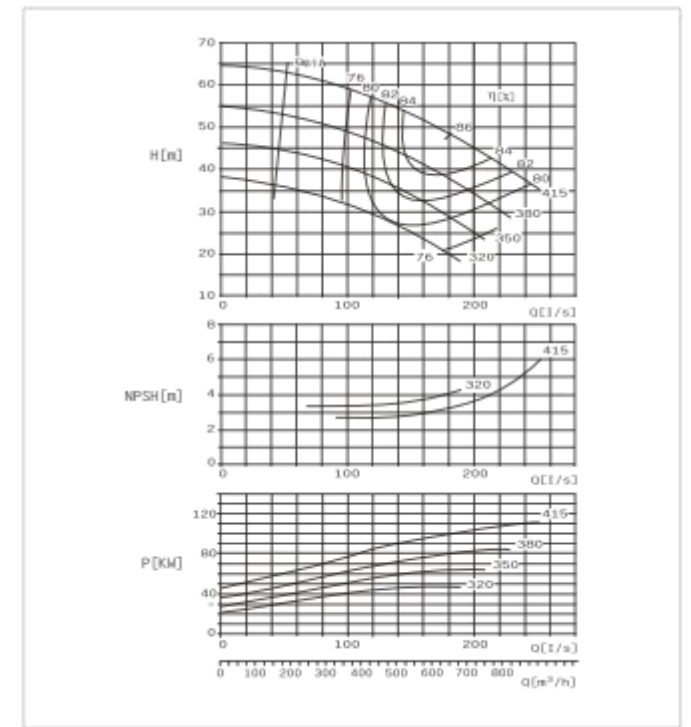

**SBS Horizontal pump installation dimension drawing**

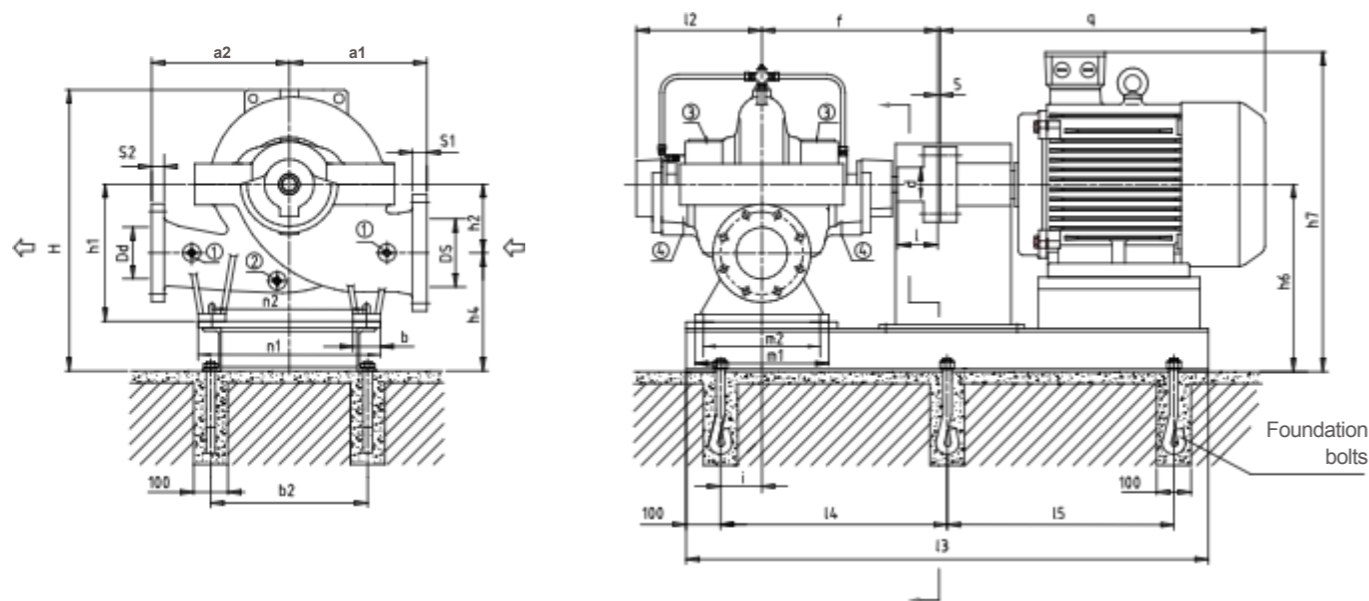

Suction flange

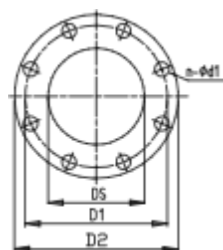

Discharge flange

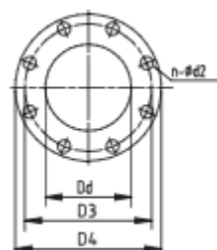

**Connection Dimensions**

- ① Pressure gauge Rp1/2
- ② Drain plug Rp1/2
- ③ Air vent Rp1/2
- ④ Leakage drains hole Rp3/4

**Parameter Chart**

Model	Capacity		Head m	Speed r/min	Eff. %	Motor power kW	NPSH m	Impeller diameter mm
	m³/h	L/S						
SBS 200-320E	556	154.4	34	1450	86	75	3.8	338
	695	193	30		87.5			
	834	231.7	25		84.5			
	518	144	29		84			
	648	180	25.5		86.5			
	778	216	21.3		83.5			
	481	133.4	25		80.5			
	601	167	21.3		85			
	720	200	17.2		80			
	440	122.2	18.9		78			
550	152.8	17	79					
612	170	15.3	77.5					
SBS 200-320F	510	141.7	32.3	1450	85.2	75	3	338
	637	176.9	28		86.5			
	765	212.5	23.4		84			
	475	132	28.5		83.8			
	594	165	24.5		86			
	713	198	20		82.9			
	445	123.6	23.8		81.3			
	558	155	21		84			
	670	186	17.2		81.8			
	412	114.4	20		78			
515	143.1	17	82					
595	165.3	14.2	78					

**Parameter Chart**

Model	Capacity		Head m	Speed r/min	Eff. %	Motor power kW	NPSH m	Impeller diameter mm
	m³/h	L/S						
SBS 200-420E	567	157.5	57	1450	84.5	132	3.9	415
	709	197	52		86.5			
	850	236.1	47		84.5			
	504	140	47.5		82.5			
	630	175	42.5		84.5			
	756	210	37.5		83			
	458	127.2	40		80.5			
	572	159	35.5		83			
	687	190.8	30		81.6			
	409	113.6	32.5		79			
511	142	27.5	81					
613	170	24	80					
SBS 200-420F	518	144	54	1450	84	110	3.5	415
	648	180	48.5		85.5			
	778	216	42		83.5			
	467	130	45		82			
	583	162	40.5		84			
	700	195	35		81.5			
	423	118	38		80			
	530	147	34.5		82			
	635	176	29		79.5			
	375	104	31.5		77.5			
468	130	28	78					
562	156	24	77.3					

**Dimensions**

Model	Suction flange ( mm )					Discharge flange ( mm )					Pump size ( mm )										WGT kg		
	DS	D1	D2	n-φd1	S1	Dd	D3	D4	n-φd2	S2	m1	m2	n1	n2	b	a1	a2	l2	f	h1		h2	H
200-320	250	355	405	12-φ28	37	200	295	340	12-φ23	35	480	430	630	560	70	450	450	430	590	500	240	885	572
200-420	250	355	405	12-φ28	37	200	295	340	12-φ23	35	480	430	630	560	70	500	500	430	590	500	240	910	577

**Installation dimensions**

Model	Motor		b2	h4	h6	h7	l3	l4	l5	i	q	Motor weight (kg)	Baseplate weight (kg)	Coupling d×l	Foudation bolts
	Frame Size	Power (kW)													
200-320	200L-6	22	670	400	640	950	1470	635	150	790	265	180	φ54×110	6-M20×400	
	225S	37				975	1470	635		840	330	192			
	225M	45				975	1500	650		865	360	195			
	250M	55				1025	1560	680		945	450	200			
	280S	75				1055	1630	715		990	640	235			
	280M	90				1055	1680	740		990	722	240			
	315S	110				1130	1750	775		1185	960	250			
	315M	132				1130	1847	800		1325	1050	260			
	315L	160				1130	1847	800		1325	1150	260			

SBS200-520 E Performance Curve n=1450r/min

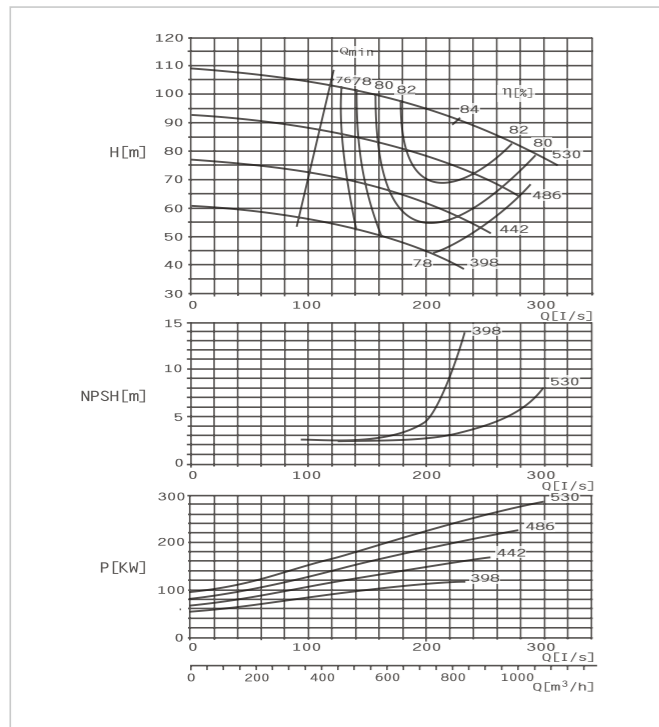

SBS200-520 F Performance Curve n=1450r/min

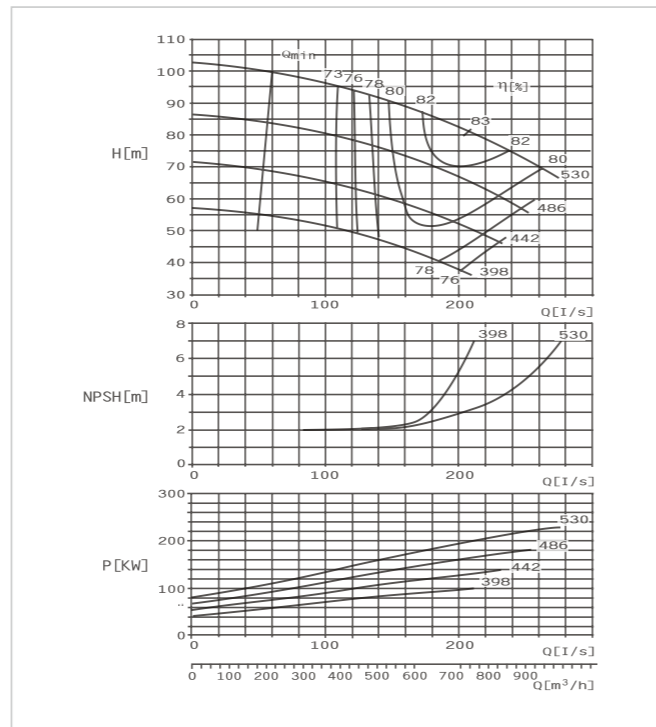

SBS200-670 E Performance Curve n=1450r/min

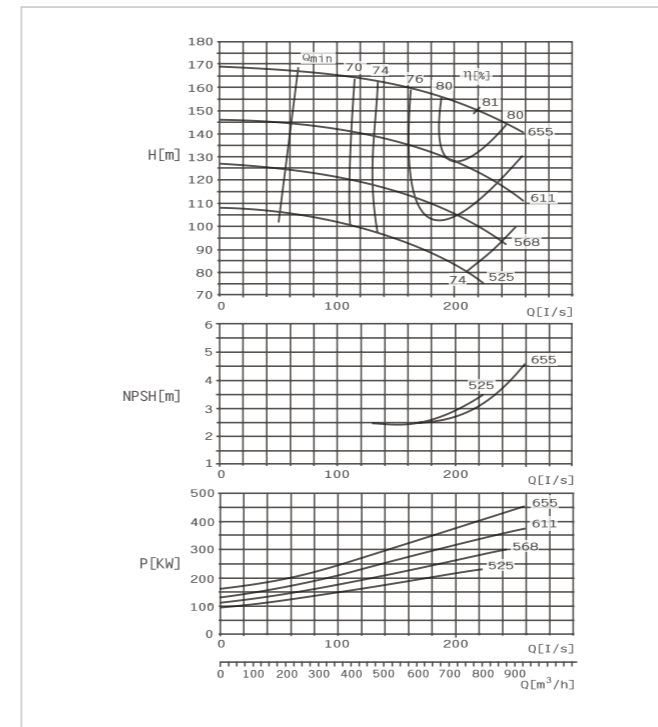

SBS200-670 F Performance Curve n=1450r/min

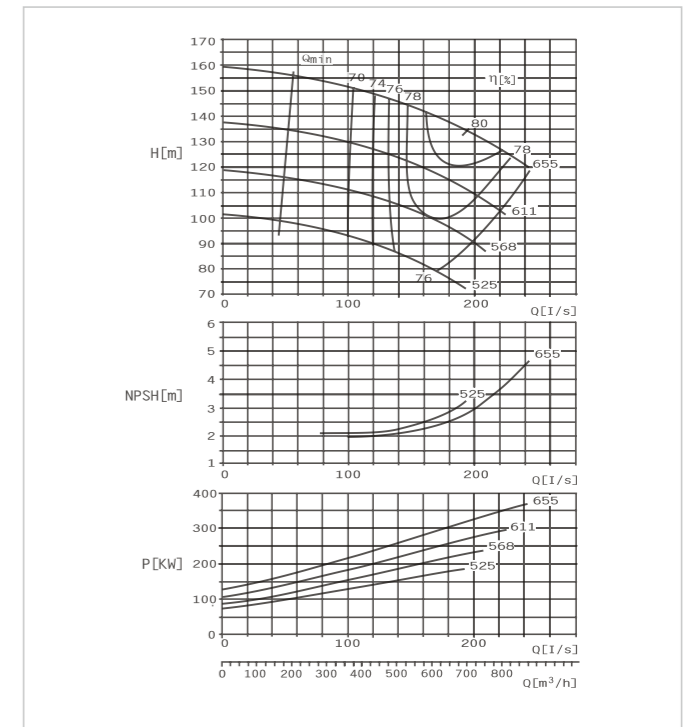

**SBS Horizontal pump installation dimension drawing**

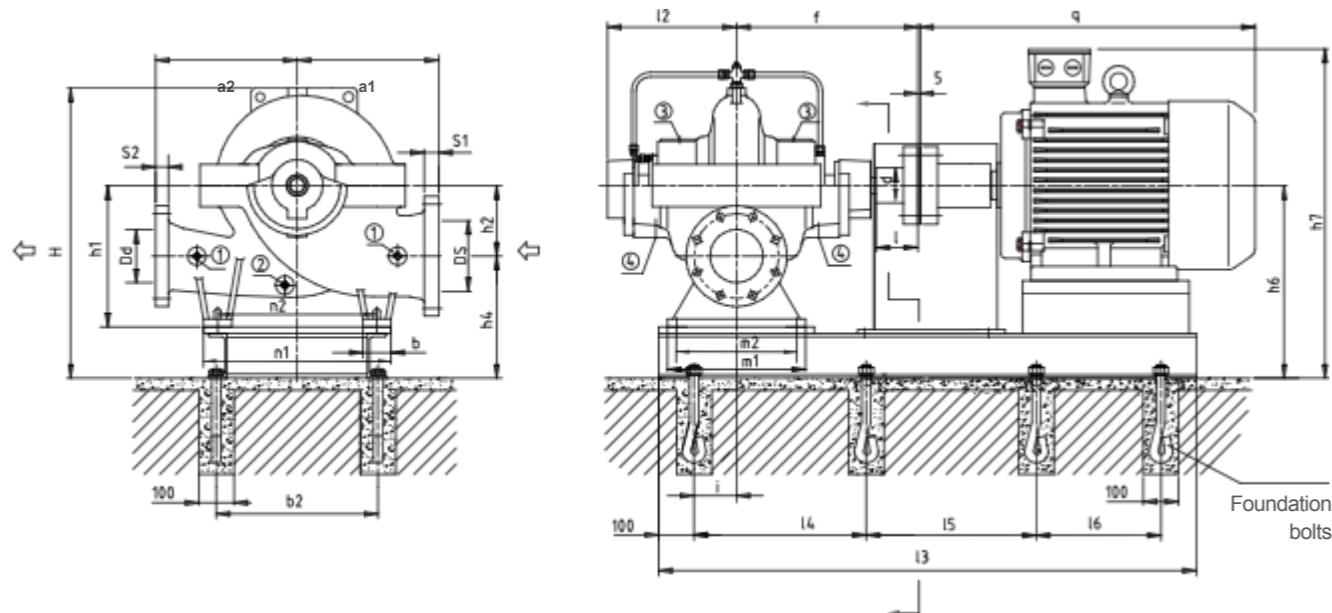

Suction flange

Discharge flange

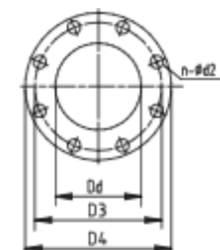
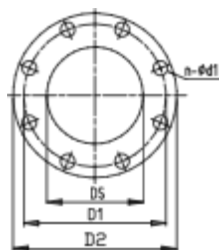

**Connection Dimensions**

- ① Pressure gauge Rp1/2
- ② Drain plug Rp1/2
- ③ Air vent Rp1/2
- ④ Leakage drains hole Rp3/4

**Parameter Chart**

Model	Capacity		Head m	Speed r/min	Eff. %	Motor power kW	NPSH m	Impeller diameter mm
	m³/h	L/S						
SBS 200-520E	654	181.7	97	1450	82.2	280	4	530
	817	227	91		84	315		
	980	272.2	83		81.5			
	605	168	82.5		80.2	220		
	756	210	76.5		83	250		
	907	252	70		80.4			
	565	156.9	67		78.1	185		
	706	196.1	62.5		81	3.7		
	847	235.2	55		78			
	518	144	52.3		75.5	132		
648	180	47.5	78.5	3.5				
778	216.1	42	76.2					
SBS 200-520F	588	163.2	88	1450	80.3	220	3.5	530
	734	204	81.7		83	250		
	880	244.8	73.2		80.3			
	556	154.4	74		79.6			
	695	193	68		81	185		
	834	231.7	60		79.3			
	524	145.6	60		78.5			
	655	182	55		80	160		
	786	218.3	48.8		78			
	478	132.8	48		76.8	110		
598	166	43.5	78					
717	199.2	38	76					

**Parameter Chart**

Model	Capacity		Head m	Speed r/min	Eff. %	Motor power kW	NPSH m	Impeller diameter mm
	m³/h	L/S						
SBS 200-670E	634	176	157.5	1450	77.7	500	3.6	655
	792	220	150		80			
	936	260	140		78.2			
	596	165.6	134.5		76.7			
	745	206.9	127		78.5			
	894	248.3	114.5		76			
	562	156.1	114.5		76			
	702	195	107		77			
	842	234	95.5		74.8			
	527	146.4	95.5		74.8			
659	183	88	76					
770	213.9	80	74					
SBS 200-670F	576	160	142	1450	77.2	400	3.4	655
	720	200	132.5		79			
	864	240	120		76			
	530	147.2	123		76.8			
	662	183.9	114.5		78.5			
	795	220.8	104		76			
	493	136.9	106		76.1			
	616	171.1	98.5		78			
	720	200	90		76			
	455	126.4	90		74.8			
569	158.1	83	77					
683	189.7	73	74					

**Dimensions**

Model	Suction flange ( mm )					Discharge flange ( mm )					Pump size ( mm )										WGT kg		
	DS	D1	D2	n-φd1	S1	Dd	D3	D4	n-φd2	S2	m1	m2	n1	n2	b	a1	a2	l2	f	h1		h2	H
200-520	250	355	405	12-φ28	37	200	295	340	12-φ23	35	480	430	770	700	70	600	500	475	655	560	300	1030	800
200-670	250	355	405	12-φ28	37	200	295	340	12-φ23	35	480	400	800	700	100	650	550	475	655	600	350	1135	914

**Installation dimensions**

Model	Motor		b2	h4	h6	h7	l3	l4	l5	l6	i	q	Motor weight (kg)	Baseplate weight (kg)	Coupling d×l	Foudation bolts
	Frame Size	Power (kW)														
200-520	315S	110	820	440	740	1230	1810	805	--	150	1185	960	326	340	φ64×140	6-M20×400
	315M	132														
	315L	160-200														
	355M	220-250														
	355L	280-315														
200-670	355L	280-315	850	440	790	1425	2036	600	600	1650	1960	355	355	8-M27×600		

SBS250-370 E Performance Curve n=1450r/min

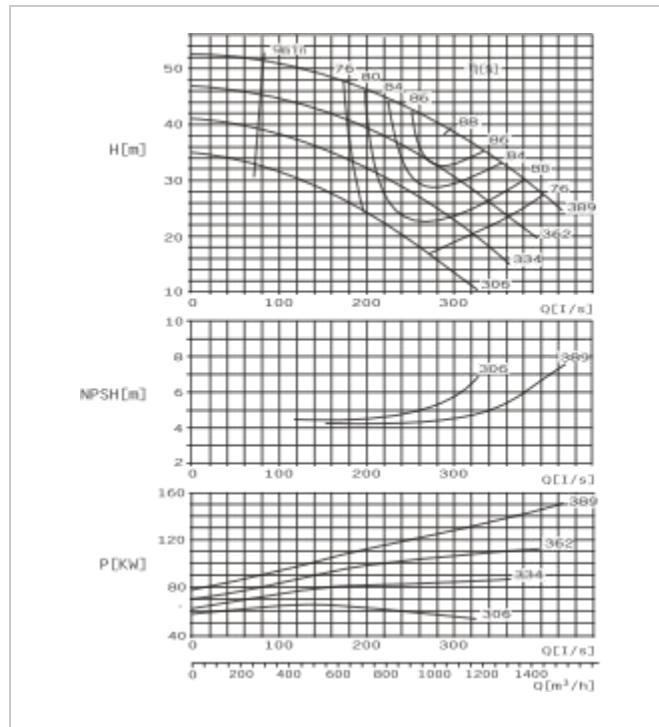

SBS250-370 F Performance Curve n=1450r/min

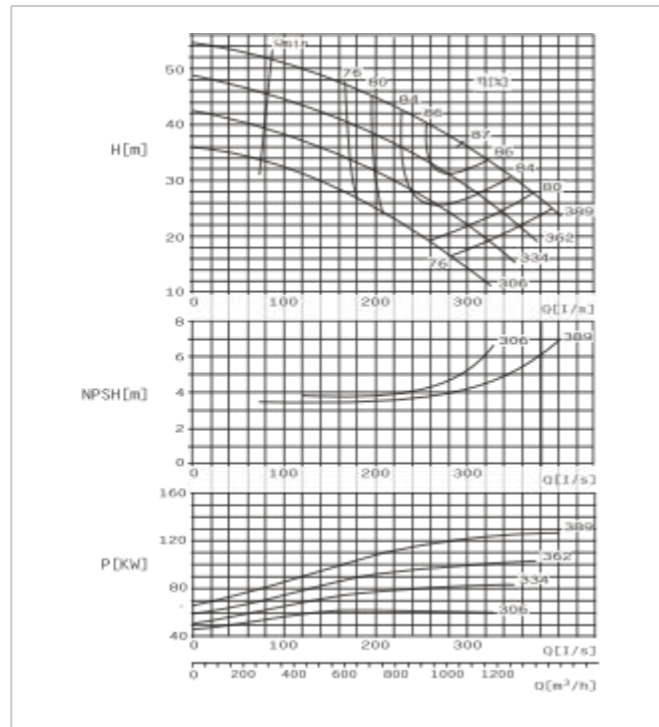

SBS250-480 E Performance Curve n=1450r/min

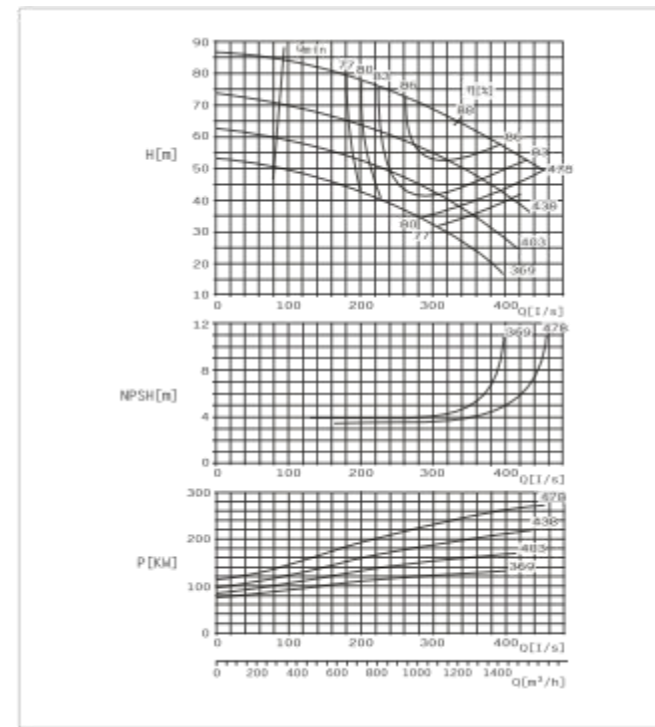

SBS250-480 F Performance Curve n=1450r/min

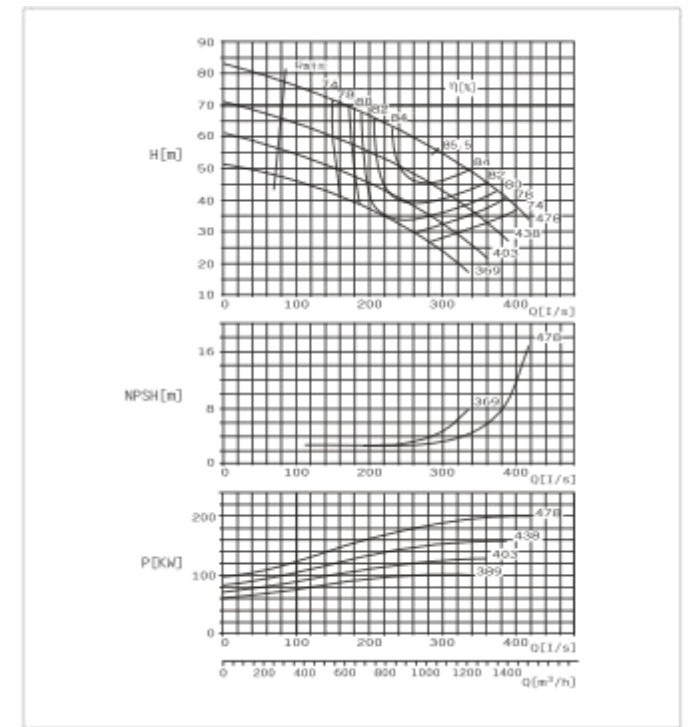

**SBS Horizontal pump installation dimension drawing**

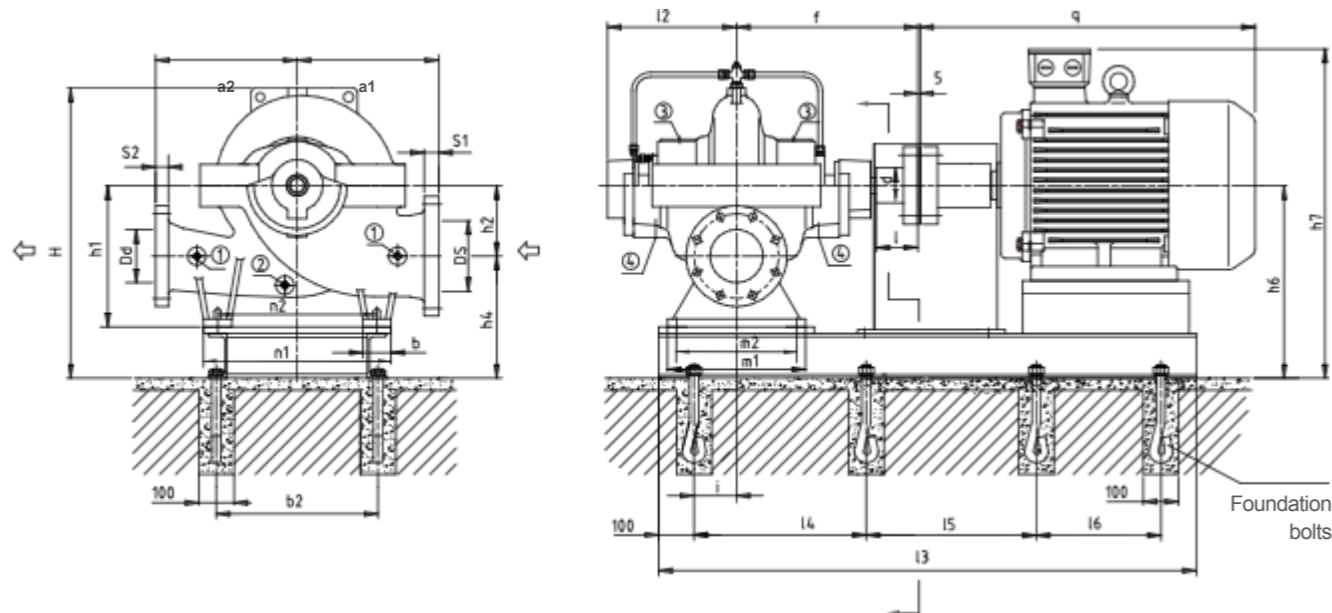

Suction flange

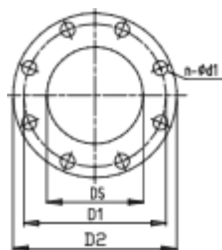

Discharge flange

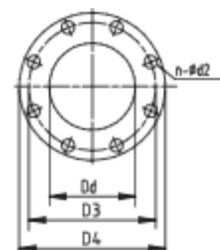

**Connection Dimensions**

- ① Pressure gauge Rp1/2
- ② Drain plug Rp1/2
- ③ Air vent Rp1/2
- ④ Leakage drains hole Rp3/4

**Parameter Chart**

Model	Capacity		Head m	Speed r/min	Eff. %	Motor power kW	NPSH m	Impeller diameter mm
	m³/h	L/S						
SBS 250-370E	840	233.3	44	1450	85.3	160	4.7	389
	1051	292	39		88			
	1260	350	33.5		84			
	795	220.8	37.5		82.3			
	994	276.1	33		86			
	1192	331.2	27.7		82.3			
	755	209.7	31.5		78			
	943	261.9	27		83			
	1131	314.4	21		77.5			
	756	210	23		76			
871	242	20	75					
1008	280	16	76					
SBS 250-370F	823	228.6	42.3	1450	84.5	132	4.7	389
	1029	286	37		87			
	1235	343	31		84.3			
	775	215.3	37		82.3			
	968	268.9	32		86			
	1162	322.8	27		82.5			
	732	203.3	32		80			
	914	253.9	27		84			
	1097	304.8	22		80			
	680	188.9	25.6		77			
850	236.1	22	82					
1020	283.3	17	77					

**Parameter Chart**

Model	Capacity		Head m	Speed r/min	Eff. %	Motor power kW	NPSH m	Impeller diameter mm
	m³/h	L/S						
SBS 250-480E	938	260.7	73.5	1450	84.8	280	4.1	478
	1173	326	66		88			
	1408	391	58		85			
	864	240	60.5		82.8			
	1080	300	55		86			
	1296	360	47.5		83			
	800	222.4	50		80			
	1000	278	45.5		83			
	1200	333.6	38		77.6			
	743	206.4	42		77			
929	258	37.5	80					
1115	309.6	32	77					
SBS 250-480F	864	240	62	1450	82.5	220	4.1	478
	1044	290	55.5		84			
	1296	360	45		80			
	780	216.7	53.5		81			
	976	271	47		84			
	1171	325.2	42		82			
	708	196.7	45		78.6			
	886	246.1	40.5		80.5			
	1063	295.2	34		78			
	642	178.3	40		74			
803	223	34.5	78.5					
963	267.5	28.5	76					

**Dimensions**

Model	Suction flange ( mm )					Discharge flange ( mm )					Pump size ( mm )										WGT kg		
	DS	D1	D2	n-φd1	S1	Dd	D3	D4	n-φd2	S2	m1	m2	n1	n2	b	a1	a2	l2	f	h1		h2	H
250-370	300	410	460	12-φ28	37	250	355	405	12-φ28	37	480	400	800	700	100	500	500	475	655	600	300	1030	745
250-480	300	410	460	12-φ28	37	250	355	405	12-φ28	37	600	520	800	700	100	550	550	535	730	600	300	1045	978

**Installation dimensions**

Model	Motor		b2	h4	h6	h7	l3	l4	l5	l6	i	q	Motor weight (kg)	Baseplate weight (kg)	Coupling d×l	Foudation bolts
	Frame Size	Power (kW)														
250-370	280S	75	850	480	780	1195	1690	745	--	150	990	640	409	423	φ64×140	6-M24×500
	280M	90														
	315S	110														
	315M	132														
	315L	160-200														
	315S	110														
	315M	132														
250-480	315L	160-200	820	510	810	1300	2000	915	--	210	1325	1050	423	440	φ74×140	6-M24×500
	355M	220-250														
	355L	280-315														
	1495	2100														
	1495	2181														
	630	660														
	1650	1725														
1650	1960															

SBS250-600 E Performance Curve n=1450r/min

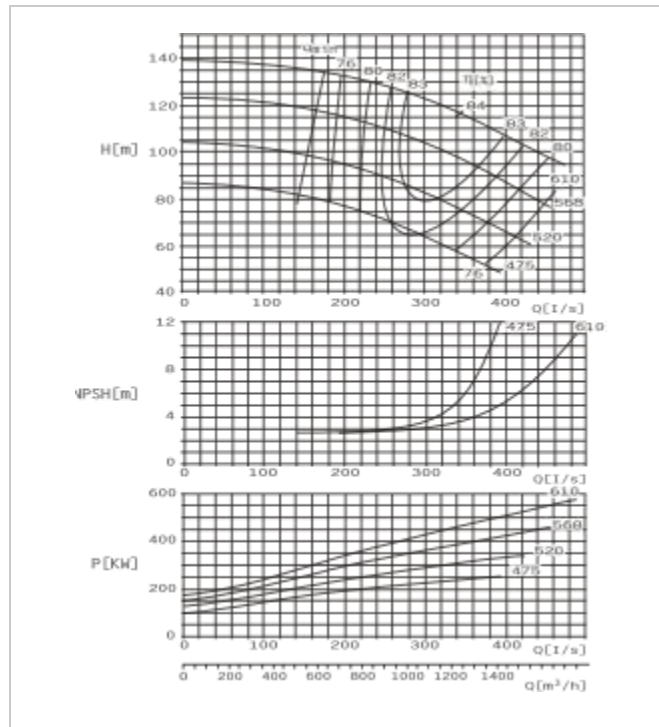

SBS250-600 F Performance Curve n=1450r/min

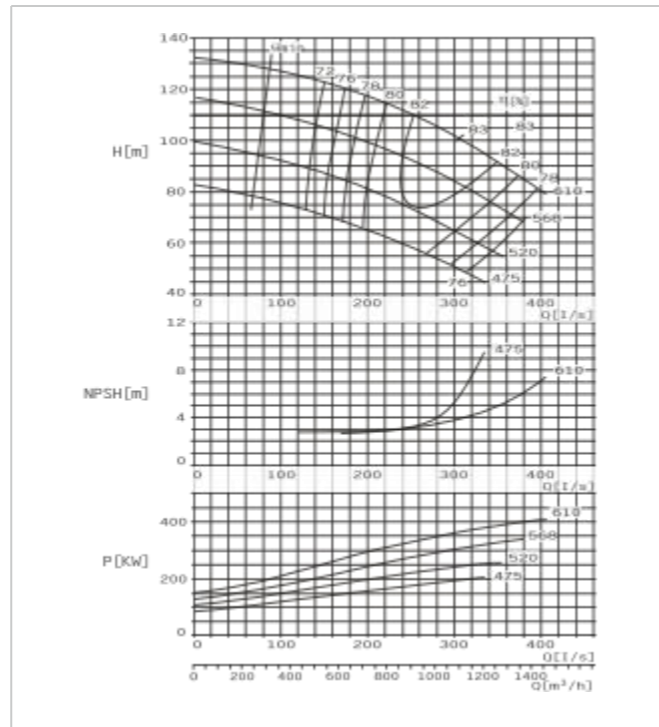

SBS250-710 E Performance Curve n=1450r/min

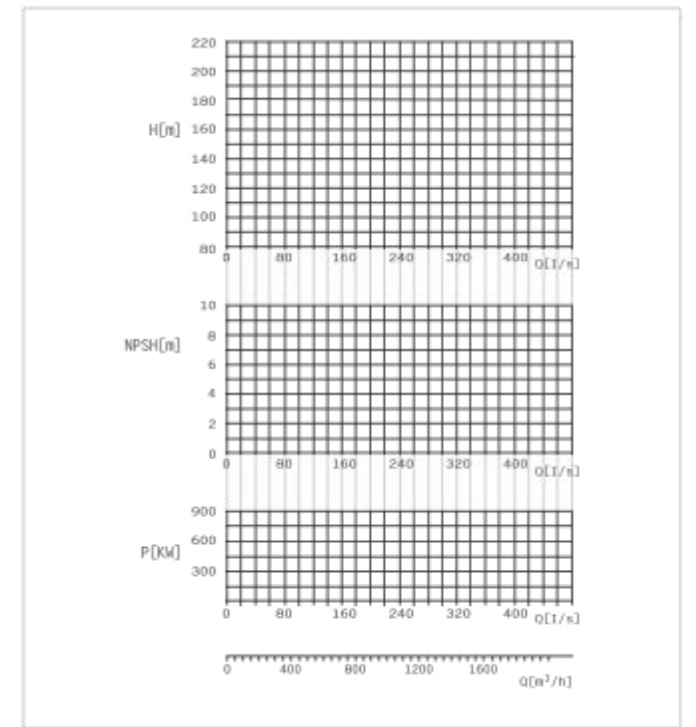
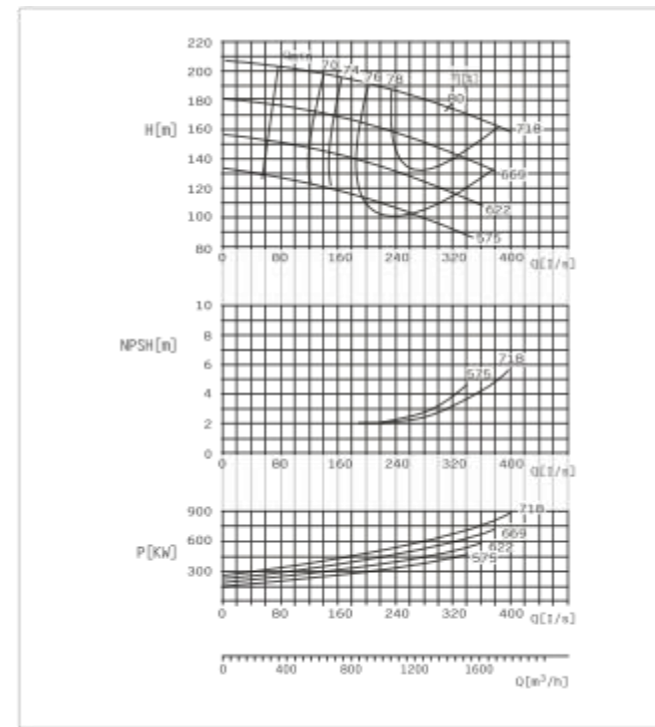

SBS Horizontal pump installation dimension drawing

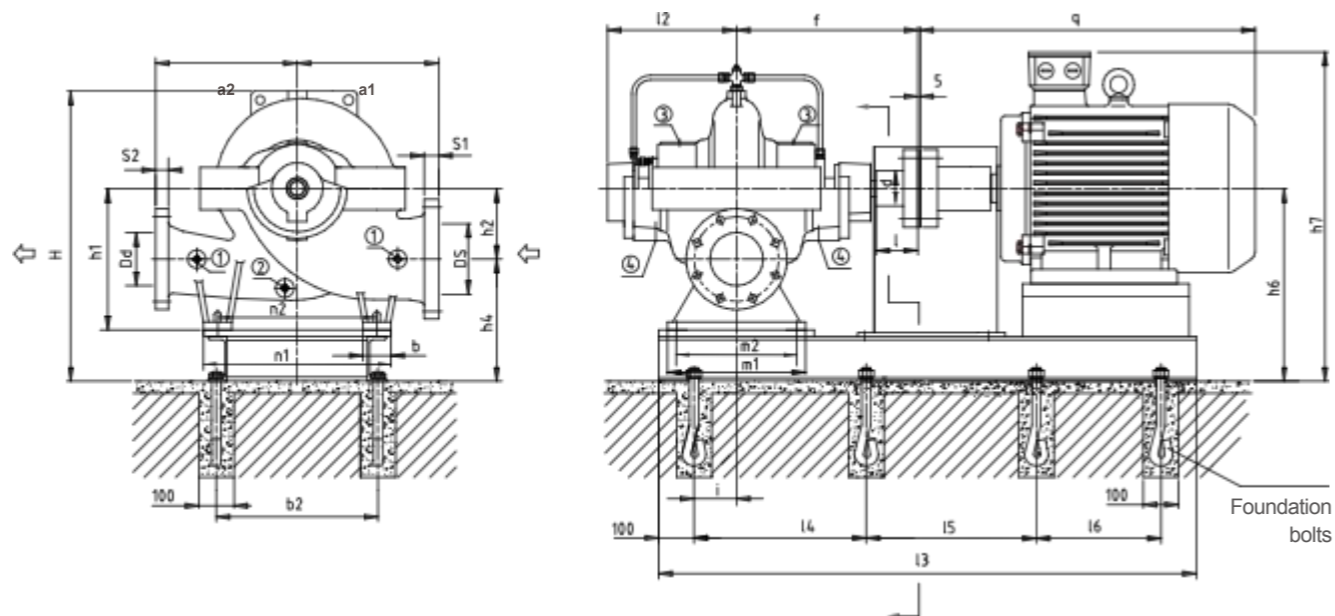

Suction flange

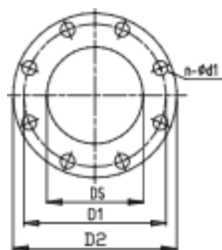

Discharge flange

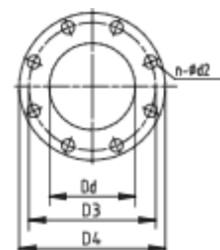

Connection Dimensions

- ① Pressure gauge Rp1/2
- ② Drain plug Rp1/2
- ③ Air vent Rp1/2
- ④ Leakage drains hole Rp3/4

Parameter Chart

Model	Capacity		Head m	Speed r/min	Eff. %	Motor power kW	NPSH m	Impeller diameter mm
	m³/h	L/S						
SBS 250-600E	994	276.1	126	1450	83	560	4.6	610
	1242	345	116		84			
	1490	413.9	105		82			
	933	259.2	108		82.5	450	4.5	568
	1166	323.9	100		83.5			
	1400	388.9	90		81.5			
	867	240.9	90		81.3	355	4.3	520
	1084	301	83		83			
	1300	361.1	73.5		81			
	800	222.2	74		80.3	250	4	475
1000	277.8	66	82.5					
1200	333.3	60	80.5					
SBS 250-600F	835	232	114	1450	81.2	400	3.7	610
	1044	290	104		83			
	1253	348	91.5		82			
	772	214.4	98		80.8	315	3.6	568
	965	268.1	90		82.5			
	1158	321.6	80		81.3			
	700	194.4	80.3		80	250	3.3	520
	875	243.1	74.5		81.5			
	1050	291.7	66		80.3			
	640	177.7	67.5		79	200	3.1	475
800	222.2	62	80.5					
960	266.7	56.5	79.5					

Parameter Chart

Model	Capacity		Head m	Speed r/min	Eff. %	Motor power kW	NPSH m	Impeller diameter mm
	m³/h	L/S						
SBS 250-710E	904	251	184	1450	78.3	800	5.4	718
	1130	314	175		80			
	1356	377	164		78.2			
	782	217	161		77.2	630	5.3	669
	978	272	152		79			
	1174	326	141		78			
	738	205	136		76.5	500	5.2	622
	922	256	128		77.5			
	1106	307	118		76.5			
	692	192	113		76.1	400	5	575
865	240	106	76.5					
1038	288	99	75.5					

Dimensions

Model	Suction flange ( mm )					Discharge flange ( mm )					Pump size ( mm )										WGT kg		
	DS	D1	D2	n-φd1	S1	Dd	D3	D4	n-φd2	S2	m1	m2	n1	n2	b	a1	a2	l2	f	h1		h2	H
250-600	300	410	460	12-φ28	37	250	355	405	12-φ28	37	600	520	800	700	100	650	550	535	730	630	350	1145	801
250-710	300	430	485	16-φ30	40	250	370	425	12-φ30	40	600	520	1020	900	120	750	650	590	795	710	430	1285	950

Installation dimensions

Model	Motor		b2	h4	h6	h7	l3	l4	l5	l6	i	q	Motor weight (kg)	Baseplate weight (kg)	Coupling d×l	Foundation bolts			
	Frame Size	Power (kW)																	
250-600	315L	200	850	490	840	1330	2030	915	--	210	1325	1250	433	438	φ74×140	6-M24×500			
	355M	220-250															1650	1725	438
	355L	280-355																	

SBS300-300 E Performance Curve n=1450r/min

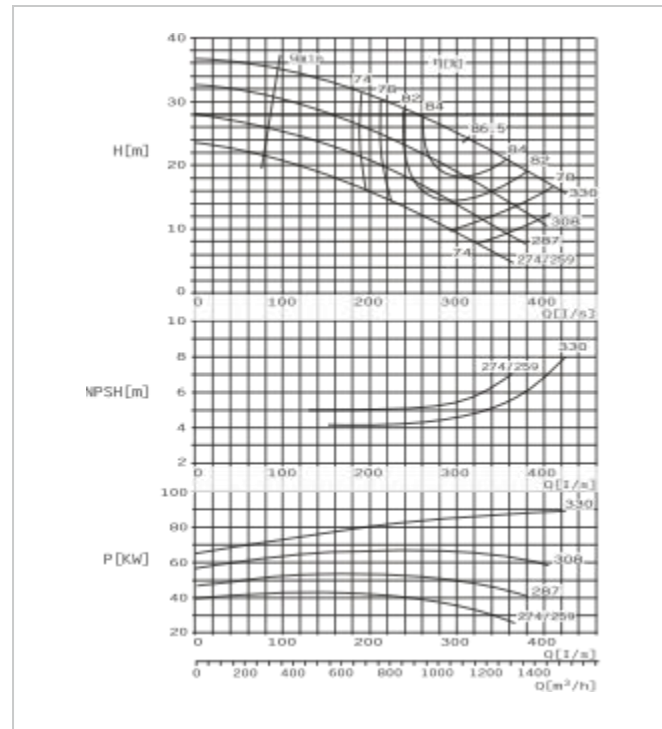

SBS300-300 F Performance Curve n=1450r/min

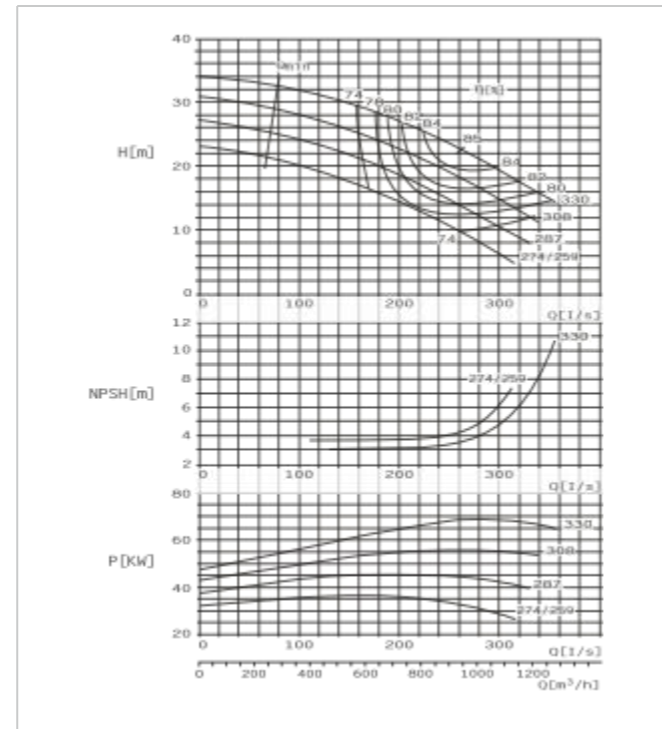

SBS300-435 E Performance Curve n=1450r/min

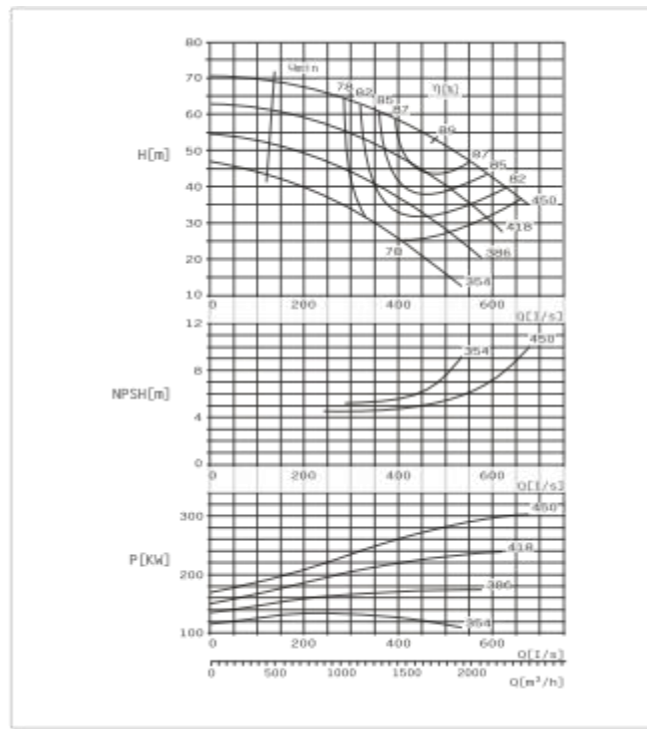

SBS300-435 F Performance Curve n=1450r/min

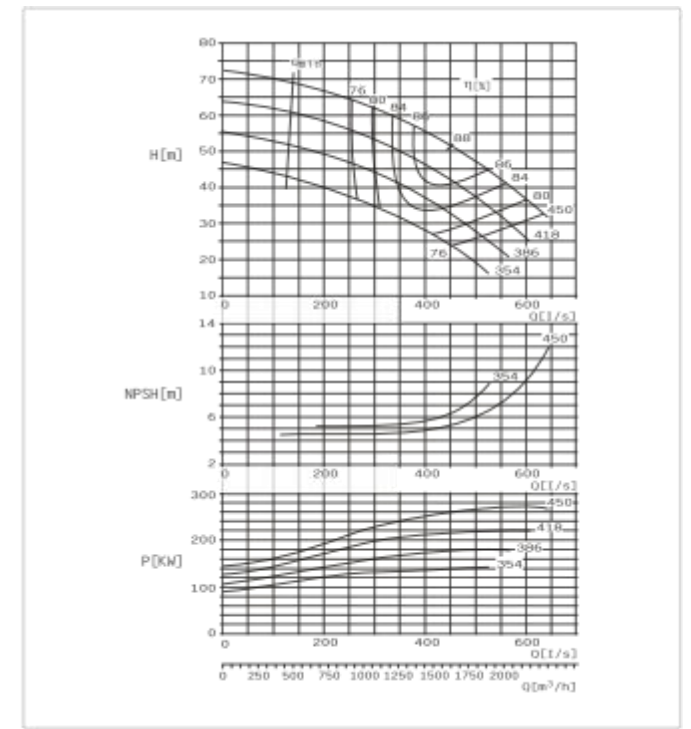

**SBS Horizontal pump installation dimension drawing**

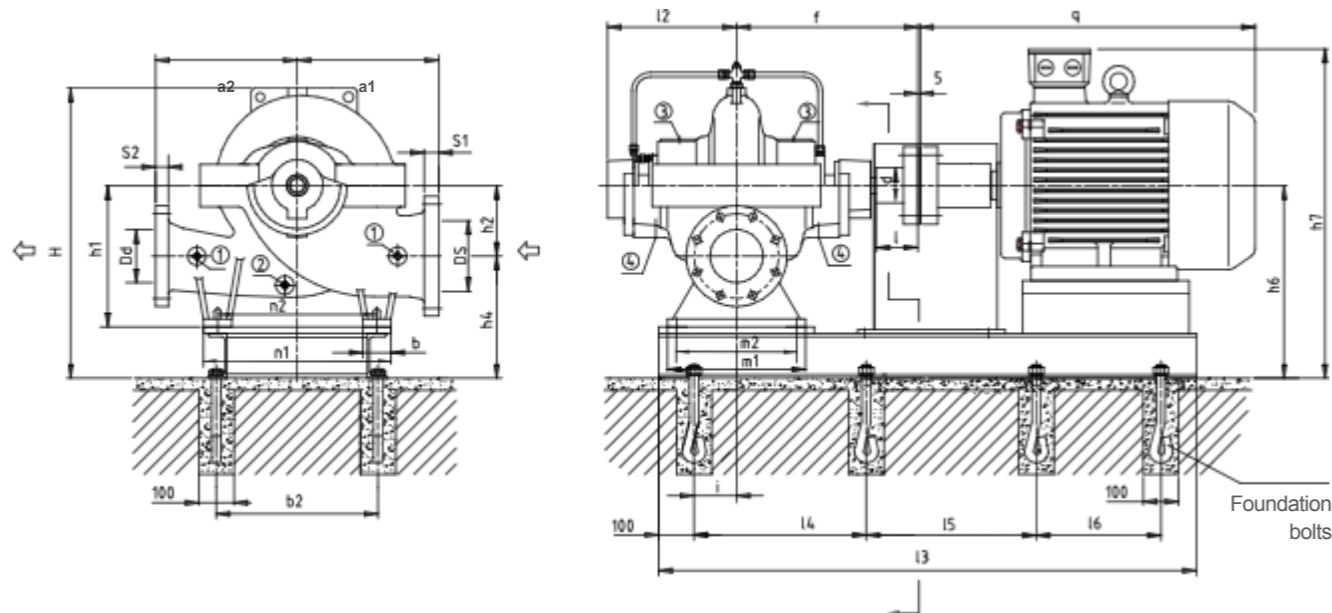

Suction flange

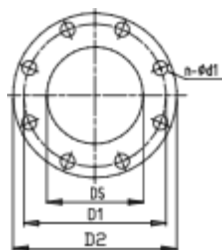

Discharge flange

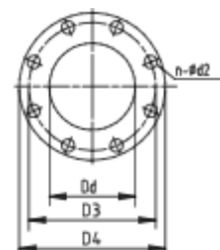

**Connection Dimensions**

- ① Pressure gauge Rp1/2
- ② Drain plug Rp1/2
- ③ Air vent Rp1/2
- ④ Leakage drains hole Rp3/4

**Parameter Chart**

Model	Capacity		Head m	Speed r/min	Eff. %	Motor power kW	NPSH m	Impeller diameter mm
	m³/h	L/S						
SBS 300-300E	878	244	28.8	1450	82.3	110	5.3	330
	1098	305	24.5		86.5			
	1318	366	20		80.3			
	835	232	23.5		80.5			
	1044	290	19.8		84.5			
	1253	348	15		81			
	806	224	19		79			
	1008	280	15.5		82			
	1210	336	11.4		78			
	772	214	15		76			
965	268	11.5	80					
1158	322	7.5	74					
SBS 300-300F	745	208	26.2	1450	83	75	4.1	330
	936	260	23		85			
	1123	312	20		80.5			
	691	192	24		84			
	864	240	20		81			
	1037	288	15.8		76.5			
	639	178	20		81			
	800	222	16.7		79			
	960	267	13.5		72			
	560	156	17.5		77			
700	194	15	77					
840	233	12	76					

**Parameter Chart**

Model	Capacity		Head m	Speed r/min	Eff. %	Motor power kW	NPSH m	Impeller diameter mm
	m³/h	L/S						
SBS 300-435E	1342	373	60	1450	85.5	315	7.1	450
	1677	466	53		89			
	2012	559	46		85.5			
	1262	350	52		84			
	1577	438	45		86.5			
	1892	526	37.5		84			
	1181	328	42.5		80			
	1476	410	36.5		84			
	1771	492	28.5		80			
	1088	302	33.8		76			
1360	378	27.5	79					
1530	425	24	78					
SBS 300-435F	1396	360	57.5	1450	84.8	315	6.9	450
	1620	450	51.5		88			
	1944	540	43.5		84.5			
	1215	338	51.5		83			
	1519	422	45		86.5			
	1823	506	37.5		84			
	1138	316	43.5		80.5			
	1422	395	37.5		84			
	1706	474	30		80			
	1066	296	35		78			
1332	370	30.5	81.5					
1598	444	24.5	77.5					

**Dimensions**

Model	Suction flange ( mm )					Discharge flange ( mm )					Pump size ( mm )										WGT kg		
	DS	D1	D2	n-φd1	S1	Dd	D3	D4	n-φd2	S2	m1	m2	n1	n2	b	a1	a2	l2	f	h1		h2	H
300-300	350	470	520	16-φ28	41	300	410	460	12-φ28	37	480	400	800	700	100	550	500	487	655	630	300	1090	810
300-435	400	525	580	16-φ31	43	300	410	460	12-φ28	37	600	520	800	700	100	650	550	540	730	670	350	1140	1151

**Installation dimensions**

Model	Motor		b2	h4	h6	h7	l3	l4	l5	l6	i	q	Motor weight (kg)	Baseplate weight (kg)	Coupling d×l	Foudation bolts
	Frame Size	Power (kW)														
300-300	180L-6	15	850	480	780	1045	1500	650	650	650	150	665	195	240	φ64×140	6-M24×500
	200L-6	22														
	225M	45														
	250M	55														
	280S	75														
	280M	90														
	315S	110														
300-435	280S-8	37	850	530	880	1310	1810	805	630	660	210	1325	1050	441	φ74×140	8-M27×600
	315M	132														
	315L	160-200														
	355M	220-250														
	355L	280-355														

SBS300-560 E Performance Curve n=1450r/min

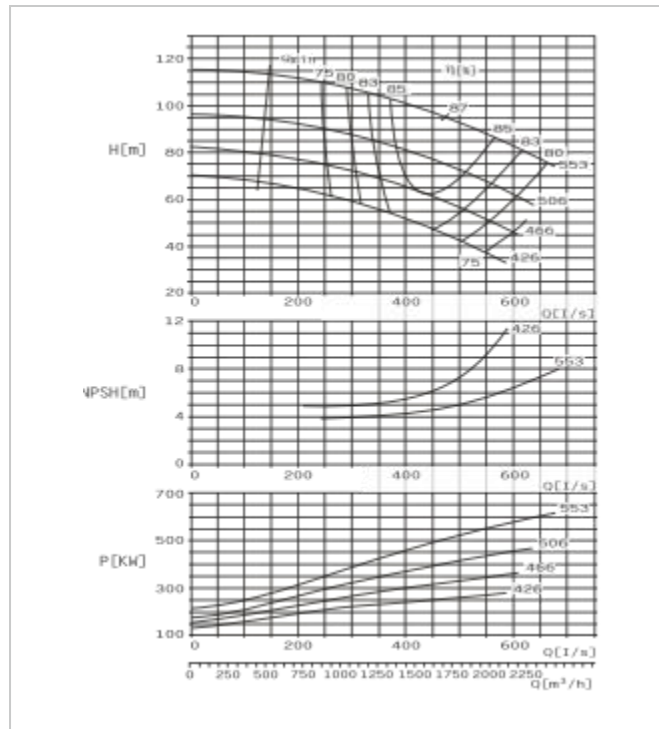

SBS300-560 F Performance Curve n=1450r/min

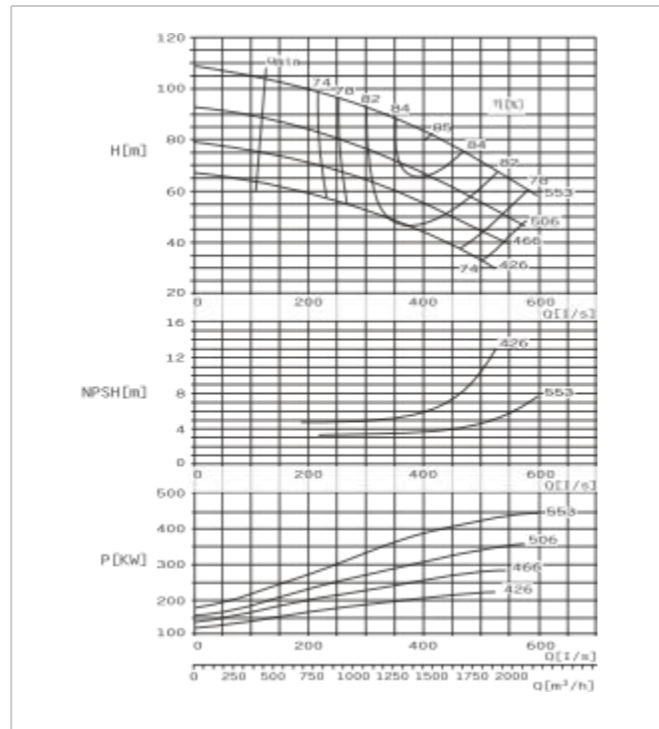

SBS300-700 E Performance Curve n=1450r/min

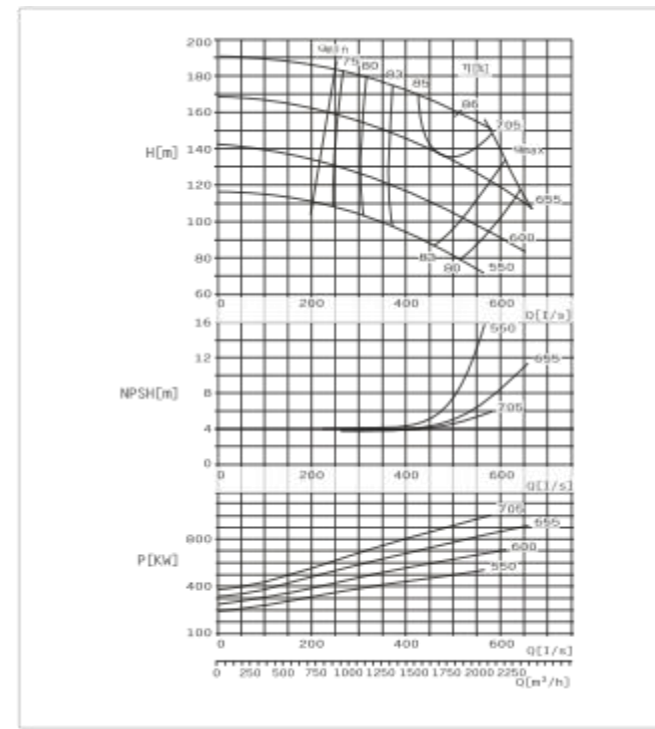

SBS300-700 F Performance Curve n=1450r/min

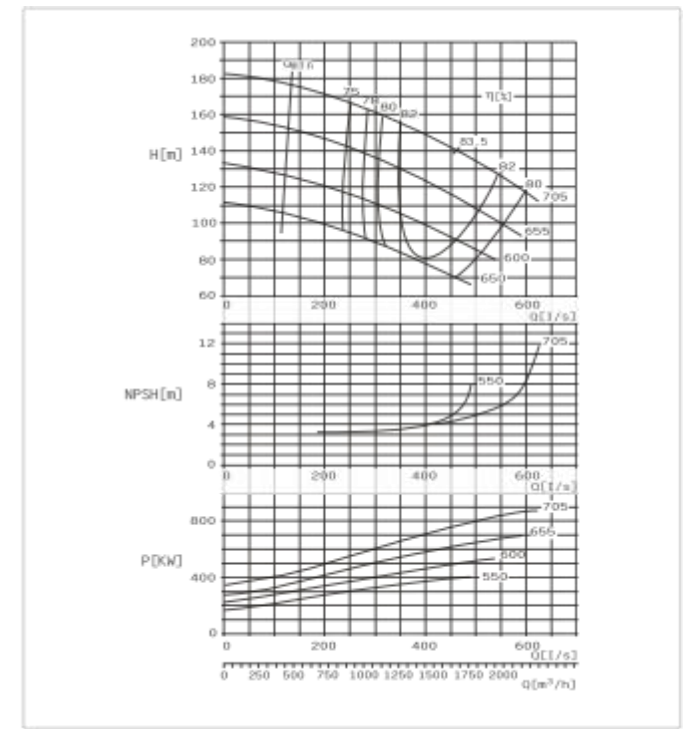

**SBS Horizontal pump installation dimension drawing**

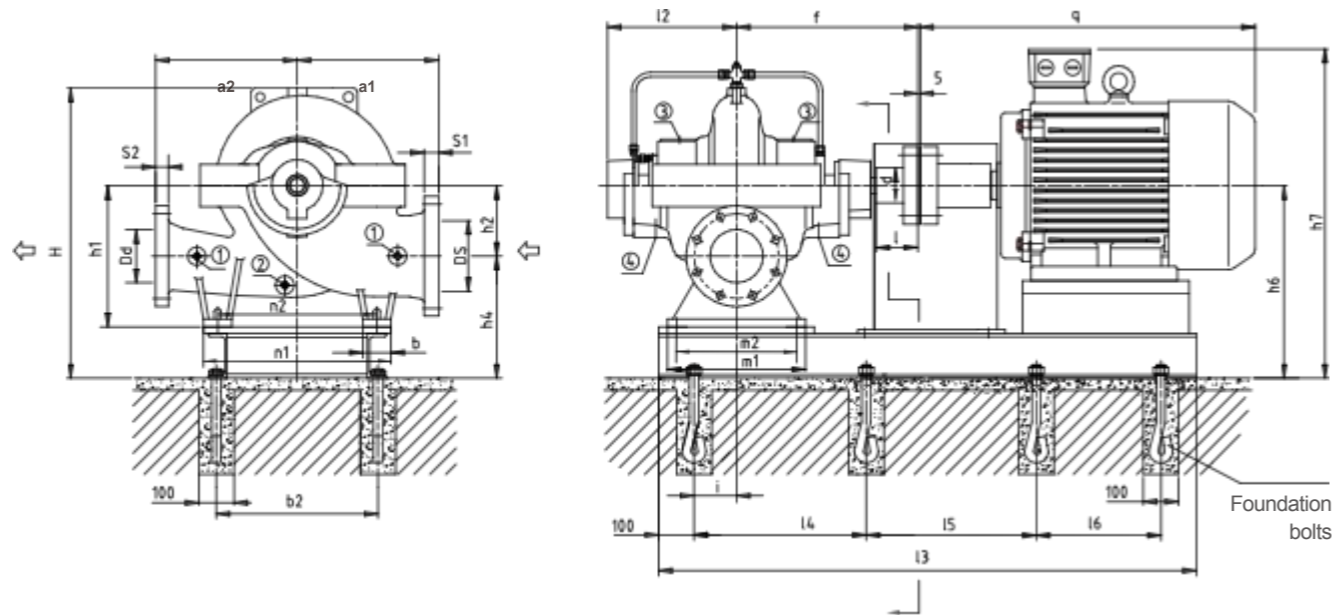

Suction flange

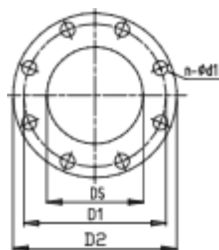

Discharge flange

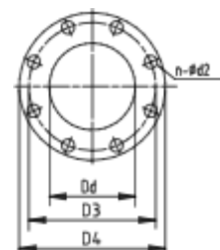

**Connection Dimensions**

- ① Pressure gauge Rp1/2
- ② Drain plug Rp1/2
- ③ Air vent Rp1/2
- ④ Leakage drains hole Rp3/4

**Parameter Chart**

Model	Capacity		Head m	Speed r/min	Eff. %	Motor power kW	NPSH m	Impeller diameter mm
	m³/h	L/S						
SBS 300-560E	1397	388	101.5	1450	85.2	630	5.7	553
	1746	485	94		87			
	2095	582	83.5		83.5			
	1316	366	83.5		83.8			
	1645	457	76		85.5			
	1974	548	67		83.3			
	1258	350	68		83			
	1573	437	62		85			
	1888	524	54		82			
	1213	337	57		81.2			
1516	421	50	83.5	280	7.2	426		
1819	505	42	80					
SBS 300-560F	1238	344	88.5	1450	83.2	450	5.15	553
	1548	430	80		85			
	1858	516	70		83			
	1158	322	75		82.7			
	1447	402	67		83.5			
	1736	482	57		81.5			
	1089	302	64		81			
	1361	378	57		83			
	1633	454	50		81.5			
	1026	285	53		79.5			
1282	356	47.5	82					
1538	427	41	80.8					

**Parameter Chart**

Model	Capacity		Head m	Speed r/min	Eff. %	Motor power kW	NPSH m	Impeller diameter mm
	m³/h	L/S						
SBS 300-700E	1469	408	170	1450	84	1120	4.95	705
	1836	510	160		86			
	2070	575	151		84.2			
	1388	386	147		84			
	1735	482	136		84.6			
	2082	578	125		83			
	1298	361	122		82.8			
	1623	451	112		84.3			
	1948	541	100		82			
	1230	342	100		82.2			
1537	427	91	84					
1845	512	80	80.5					
1350	375	152	82.3	800/900	5.15	705		
1688	469	139	83.5					
2026	563	124	81.5					
1258	350	130	82					
1573	437	119	83	710	4.85	655		
1888	524	105	81					
1160	322	108	81	560	4.35	600		
1450	403	99	82.5					
1740	483	87	80.5					
1074	298	90	80.3					
1342	373	81	82	400	4.1	550		
1610	447	71.5	80.3					

**Dimensions**

Model	Suction flange ( mm )					Discharge flange ( mm )					Pump size ( mm )										WGT kg		
	DS	D1	D2	n-φd1	S1	Dd	D3	D4	n-φd2	S2	m1	m2	n1	n2	b	a1	a2	l2	f	h1		h2	H
300-560	400	525	580	16-φ31	43	300	410	460	12-φ28	37	600	520	1050	950	100	700	650	610	810	710	350	1240	1368
300-700	400	550	620	16-φ36	48	300	430	485	16-φ30	40	600	520	1050	950	100	750	650	630	810	750	400	1350	1964

**Installation dimensions**

Model	Motor		b2	h4	h6	h7	l3	l4	l5	l6	i	q	Motor weight (kg)	Baseplate weight (kg)	Coupling d×l	Foudation bolts
	Frame Size	Power (kW)														
300-560	355M	220-250	1100	570	920	1565	2300	700	700	210	1650	1725	504	φ84×170	8-M27×600	
	355L	280-355														2150

SBS350-360 E Performance Curve n=1450r/min

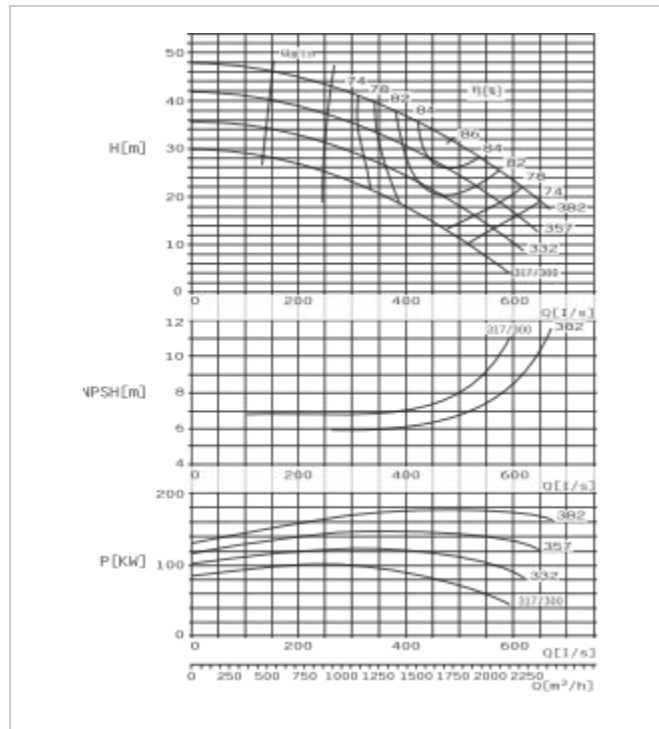

SBS350-360 F Performance Curve n=1450r/min

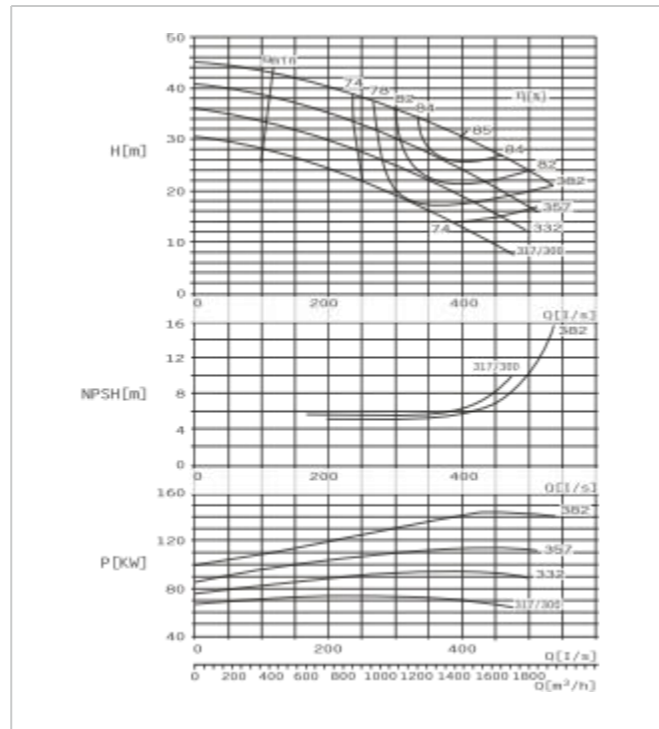

SBS350-430 E Performance Curve n=1450r/min

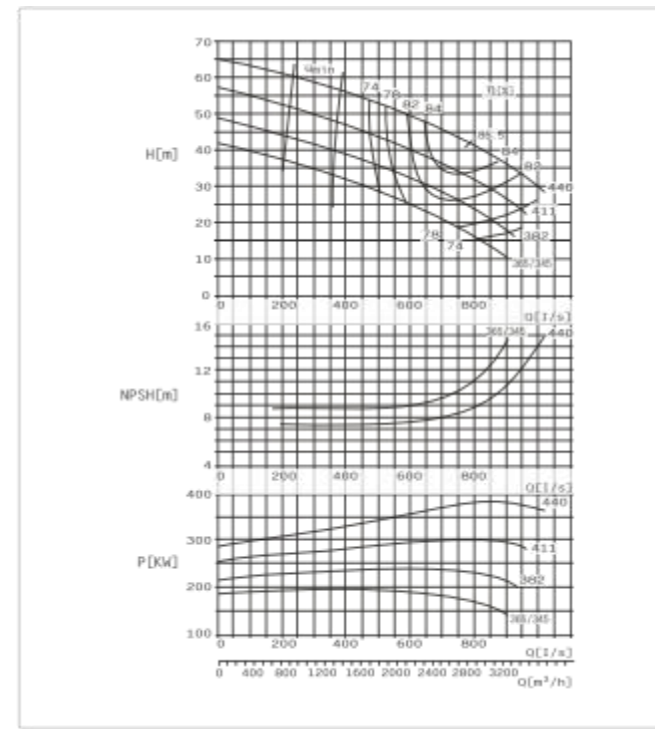

SBS350-430 F Performance Curve n=1450r/min

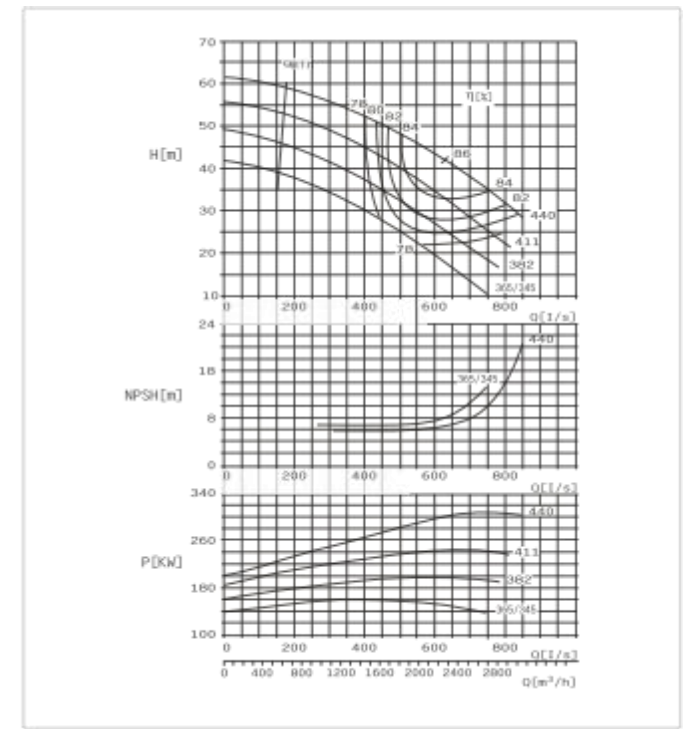

**SBS Horizontal pump installation dimension drawing**

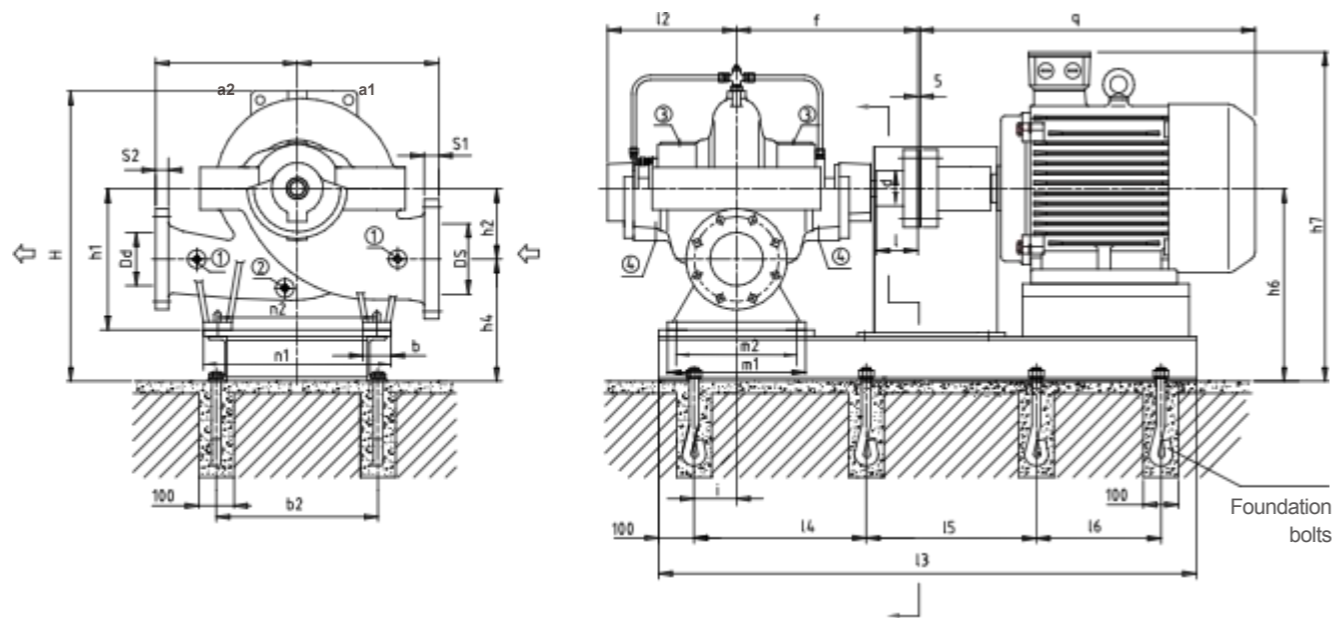

Suction flange

Discharge flange

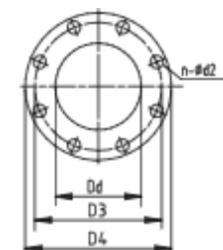
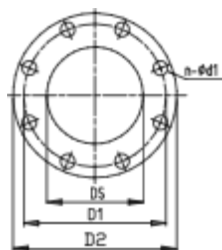

**Connection Dimensions**

- ① Pressure gauge Rp1/2
- ② Drain plug Rp1/2
- ③ Air vent Rp1/2
- ④ Leakage drains hole Rp3/4

**Parameter Chart**

Model	Capacity		Head m	Speed r/min	Eff. %	Motor power kW	NPSH m	Impeller diameter mm
	m³/h	L/S						
SBS 350-360E	1385	385	37.5	1450	83	200	8.1	382
	1731	481	32		86.5			
	2077	577	25		81			
	1354	376	32		81			
	1692	470	26.5		85			
	2030	564	20		80			
	1313	365	26.5		78.8			
	1641	456	21		83			
	1969	547	15		78			
	1282	356	20		76.3			
1602	445	15	80.5					
1922	474	9	74					
SBS 350-360F	1138	316	35.5	1450	83	160	6.2	382
	1422	395	31		85.5			
	1706	474	25.8		83.3			
	1068	297	30.5		81			
	1335	371	26.3		84			
	1602	445	21.3		81			
	1016	282	25.6		79			
	1270	353	22.5		82			
	1524	423	17.5		78			
	950	264	21.5		75.5			
1188	330	17.8	78					
1397	388	13.7	74					

**Parameter Chart**

Model	Capacity		Head m	Speed r/min	Eff. %	Motor power kW	NPSH m	Impeller diameter mm
	m³/h	L/S						
SBS 350-430E	2194	610	49.5	1450	84	400	9	440
	2743	762	43.5		87.5			
	3292	914	35		84.7			
	2108	586	41.5		82			
	2635	732	35		85.5			
	3162	878	27		82.8			
	2050	570	33		80			
	2563	712	27.5		84			
	3076	854	20		80			
	1987	552	27		78			
2484	690	21.5	81					
2981	828	15	76.3					
SBS 350-430F	1786	496	48	1450	84.2	315	9	440
	2232	620	42.5		86.5			
	2678	744	35		84.2			
	1670	464	42.5		81.5			
	2088	580	36		84.5			
	2506	696	28.8		82			
	1590	442	35		78.5			
	1987	552	30		82			
	2384	662	23.5		78.2			
	1486	413	30		76			
1858	516	25	78.5					
2230	619	18.5	76					

**Dimensions**

Model	Suction flange ( mm )					Discharge flange ( mm )					Pump size ( mm )										WGT kg		
	DS	D1	D2	n-φd1	S1	Dd	D3	D4	n-φd2	S2	m1	m2	n1	n2	b	a1	a2	l2	f	h1		h2	H
350-360	400	525	580	16-φ31	43	350	470	520	16-φ28	41	600	520	800	700	100	650	550	540	730	670	350	1185	1016
350-430	450	585	640	20-φ30	44	350	470	520	16-φ28	41	600	520	1050	950	100	750	650	620	810	750	400	1315	1689

**Installation dimensions**

Model	Motor		b2	h4	h6	h7	l3	l4	l5	l6	i	q	Motor weight (kg)	Baseplate weight (kg)	Coupling d×l	Foudation bolts			
	Frame Size	Power (kW)																	
350-360	280S-6	45	850	530	880	1295	1880	840	---	210	990	555	362	---	φ74×140	6-M24×500			
	280M	90															1045	722	415
	315S	110															1370	1950	875
	315M	132															1370	2047	900
	315L	160-200															1370	2047	915
	315M-6	90															1450	2110	955
350-430	315L	200	1100	560	960	1525	2200	660	660	210	1325	1725	505	---	φ84×170	8-M27×600			
	355M	220-250															1450	2110	955
	355L	280-355															1605	2300	700
	---	---															---	---	---
	---	---															---	---	---
	---	---															---	---	---

SBS350-510 E Performance Curve n=1450r/min

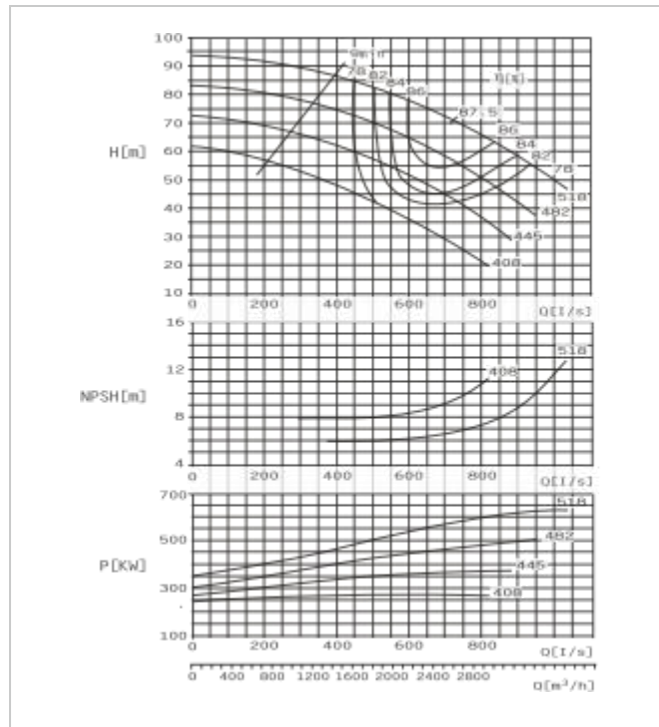

SBS350-510 F Performance Curve n=1450r/min

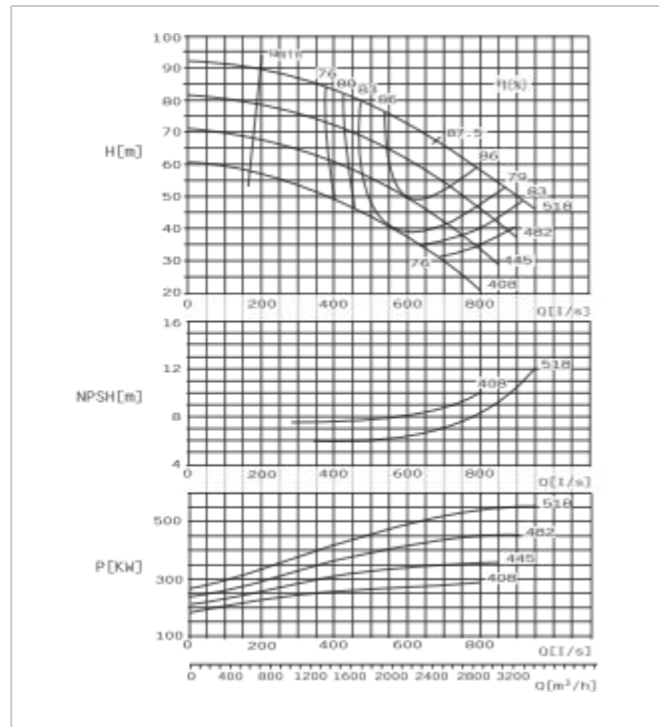

SBS350-590 E Performance Curve n=1450r/min

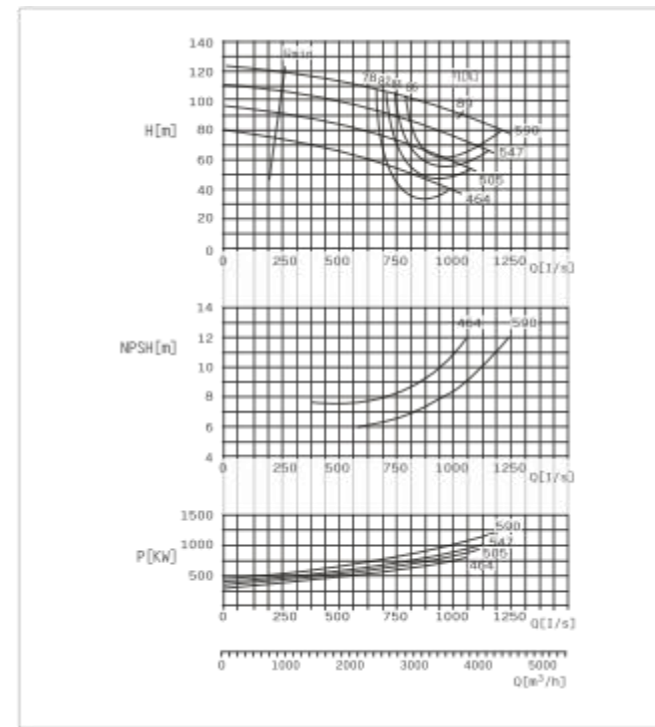

SBS350-700 Performance Curve n=960r/min

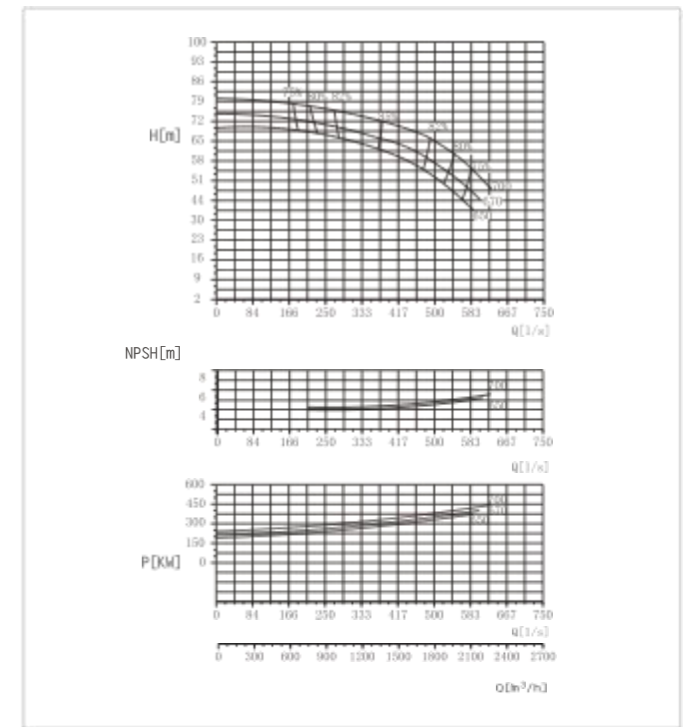

**SBS Horizontal pump installation dimension drawing**

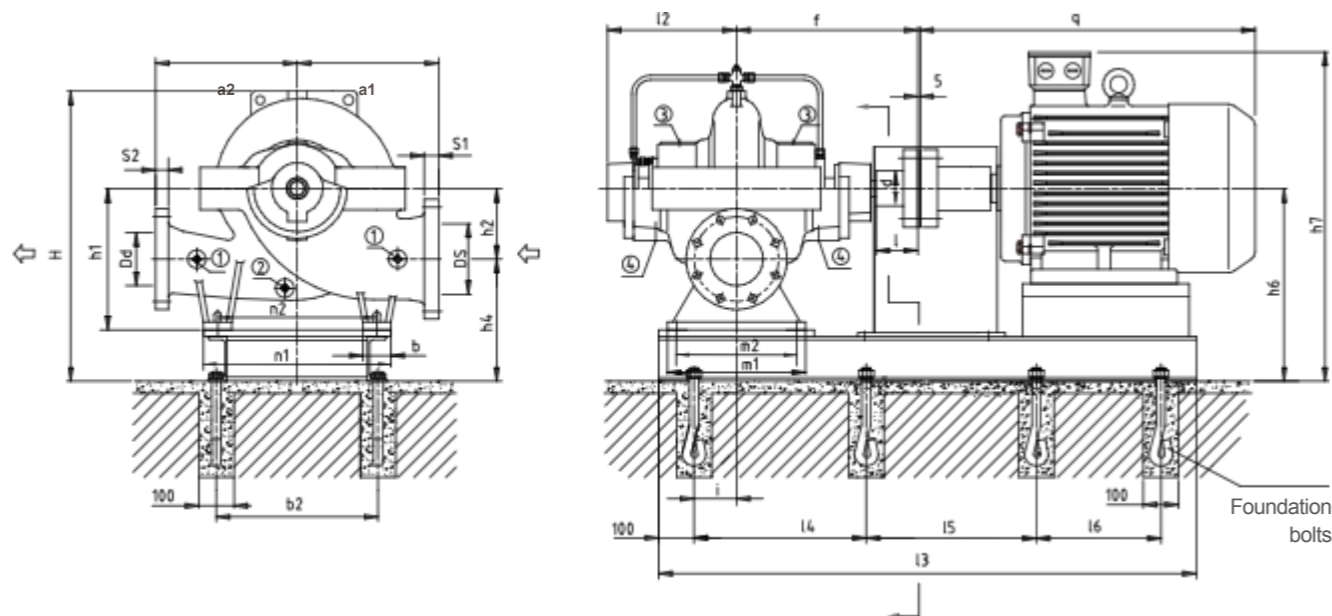

Suction flange

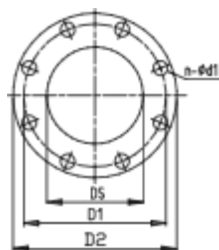

Discharge flange

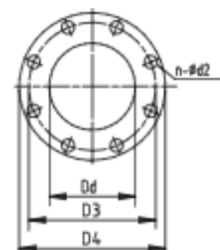

**Connection Dimensions**

- ① Pressure gauge Rp1/2
- ② Drain plug Rp1/2
- ③ Air vent Rp1/2
- ④ Leakage drains hole Rp3/4

**Parameter Chart**

Model	Capacity		Head m	Speed r/min	Eff. %	Motor power kW	NPSH m	Impeller diameter mm
	m³/h	L/S						
SBS 350-510E	2088	580	80	1450	86	630	10	518
	2610	725	70		88.5			
	3132	870	60		84.7			
	1944	540	68		84.5	500	10.7	482
	2430	675	60		87			
	2916	810	50		84			
	1786	496	57.5		81	400	11	445
	2232	620	50		86			
	2678	744	40		81			
	1656	460	45		76	315	11.5	408
2070	575	38	79					
2484	690	30	77					
SBS 350-510F	1958	544	76	1450	87	560	9.9	518
	2448	680	67		88			
	2938	816	57		86			
	1814	504	67.5		85	450	10.2	482
	2268	630	59.5		87			
	2722	756	50		85			
	1670	464	58		82.5	400	10.4	445
	2088	580	50		85			
	2506	696	41.5		82.5			
	1555	432	47.5		78	315	10.7	408
1944	540	41.5	83					
2333	648	34.5	80					

**Parameter Chart**

Model	Capacity		Head m	Speed r/min	Eff. %	Motor power kW	NPSH m	Impeller diameter mm
	m³/h	L/S						
SBS 350-590E	3036	843	100	1450	86.5	1250	9.9	590
	3795	1054	90		89			
	4500	1250	78		84			
	2834	787	88		85.1	1000	10.7	547
	3543	984	77.2		87			
	4162	1156	66		84			
	2604	723	74		81	710	11	505
	3255	904	64.3		86			
	3906	1085	53		82			
	2556	710	56		78.5	560	11.5	464
3020	839	48.9	79					
3623	1006	40.6	77.5					
SBS 350-700	1400	388.9	72.0	960	334.6	82.0	5.0	700
	1750	486.1	66		369.9			
	2100	583.3	55.0		419.2	75.0	4.8	670
	1340	372.2	66.0		300.8			
	1675	465.3	60		332.2	83.0	4.6	650
	2010	558.3	50.4		372.6			
	1300	361.1	62.1		278.1	79.0	4.6	650
	1625	451.4	57		307.0			
	1950	541.7	47.4		344.8	73.0		

**Dimensions**

Model	Suction flange ( mm )					Discharge flange ( mm )					Pump size ( mm )										WGT kg		
	DS	D1	D2	n-φd1	S1	Dd	D3	D4	n-φd2	S2	m1	m2	n1	n2	b	a1	a2	l2	f	h1		h2	H
350-510	450	585	640	20-φ30	44	350	470	520	16-φ28	41	600	520	1050	950	100	700	650	620	810	750	400	1300	1996
350-590	500	650	715	20-φ34	56	350	470	520	16-φ28	41	930	810	1050	830	220	731	650	720	910	760	410	1375	2150
350-700	500	650	715	20-φ34	56	350	470	520	16-φ28	41	790	740	1020	920	100	820	820	720	810	760	390	1340	2650

**Installation dimensions**

Model	Motor		b2	h4	h6	h7	l3	l4	l5	l6	i	q	Motor weight (kg)	Baseplate weight (kg)	Coupling d×l	Foudation bolts
	Frame Size	Power (kW)														
350-510	355L	280-355	1100	560	960	1605	2300	700	700	210	1325	2150	527	φ84×170	8-M27×600	

SBS350-620 E Performance Curve n=1450r/min

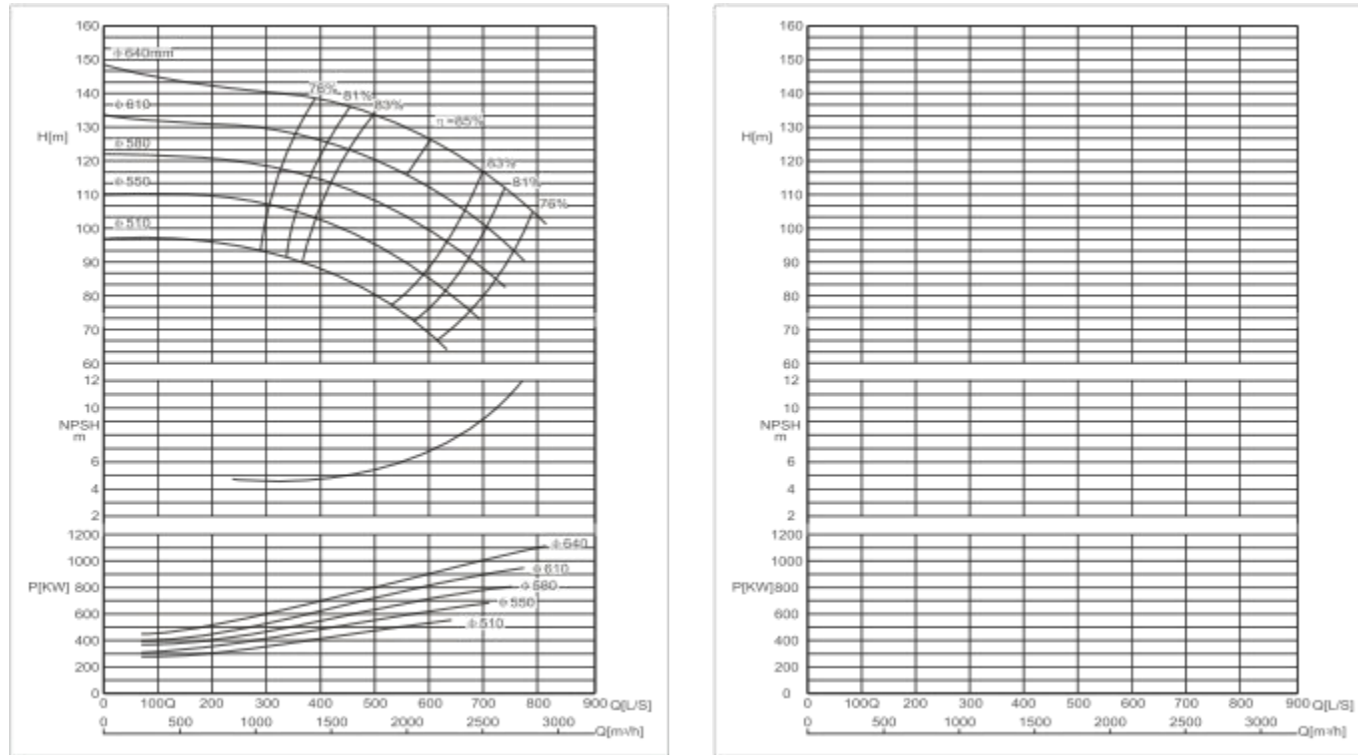

SBS400-540 E Performance Curve n=1450r/min

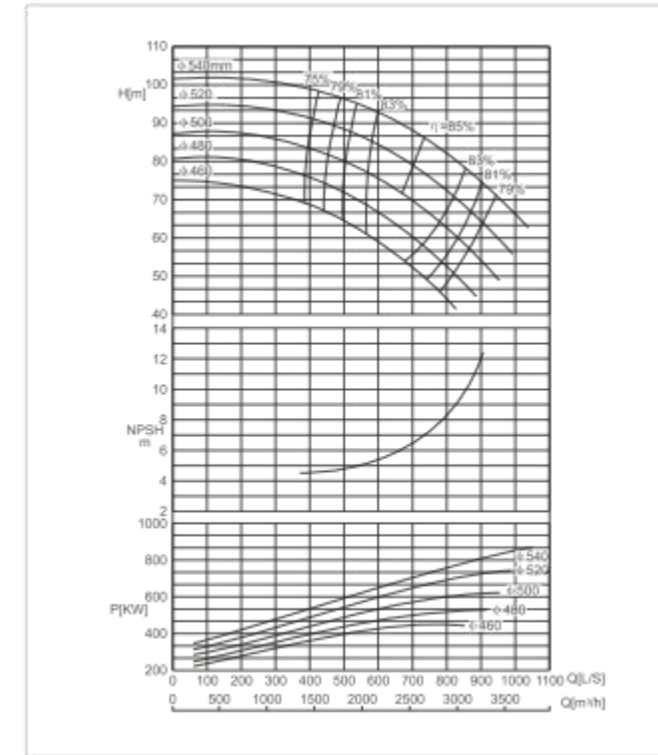

SBS400-540 F Performance Curve n=1450r/min

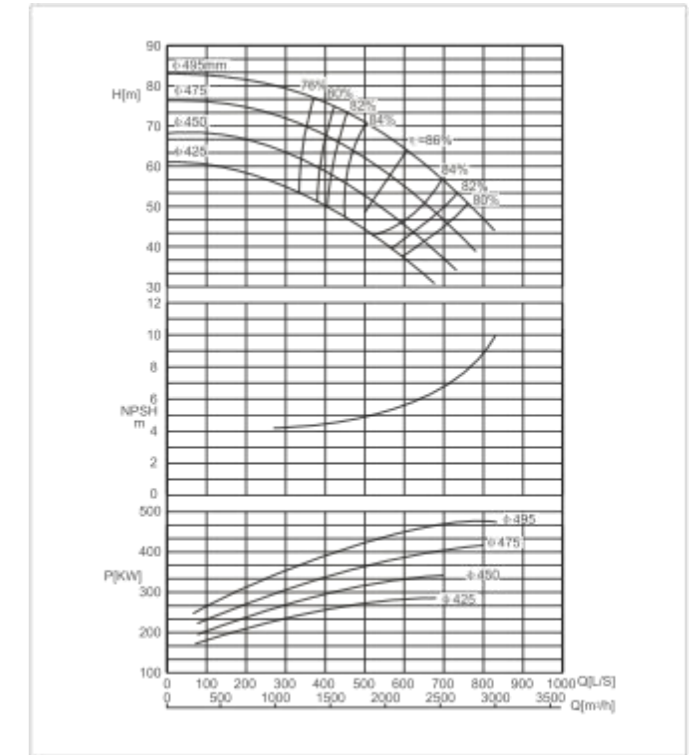

SBS Horizontal pump installation dimension drawing

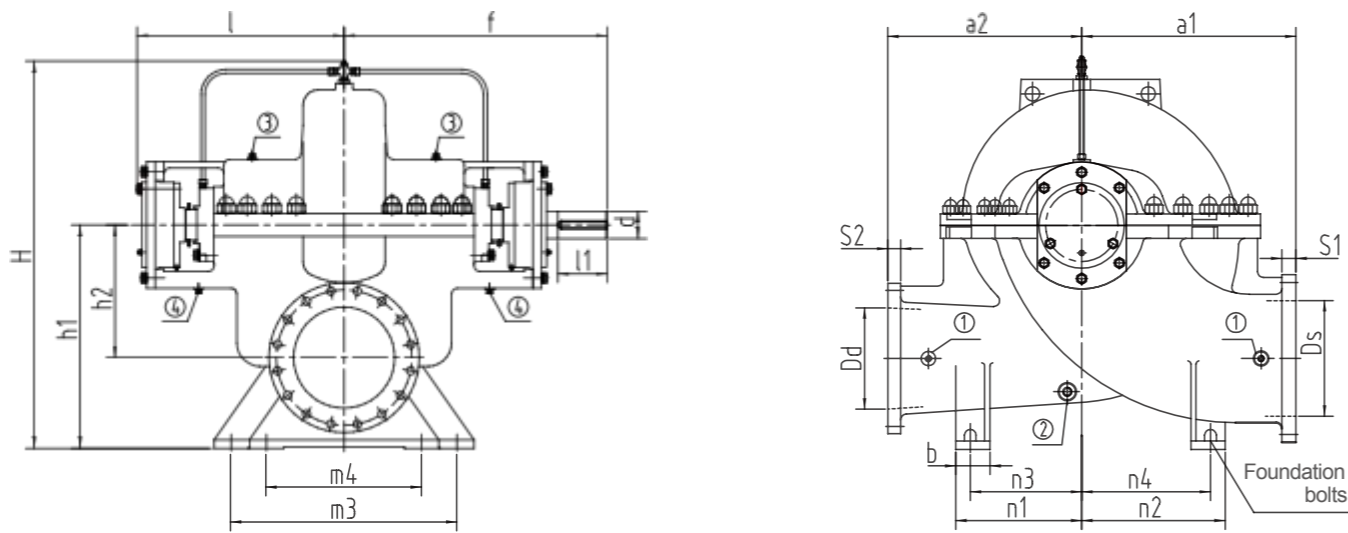

Suction flange Discharge flange

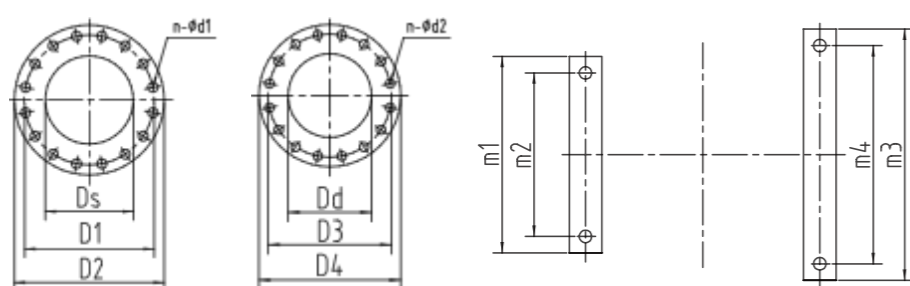

Connection Dimensions

- ① Pressure gauge Rp1/2
- ② Drain plug Rp1/2
- ③ Air vent Rp1/2
- ④ Leakage drains hole Rp3/4

Parameter Chart

Model	Capacity		Head	Speed	Eff.	Motor power	NPSH	Impeller diameter	
	m³/h	L/S	m	r/min	%	kW	m	mm	
SBS 350-620E	1320	366.7	139	1450	76	1000	7	640	
	2200	611.1	125		85				
	2640	733.3	111		81				
	1200	333.3	129		76	900			6.5
	2100	583.3	116		85				
	2500	694.4	104		81				
	1130	313.9	118		76	800			5.8
	1900	527.8	107		85				
	2350	652.8	93		82.5				
	1100	305.6	108		76	630			5.5
1830	508.3	94	84						
2300	638.9	80	81						
1020	283.3	94	76	560	5.2				
1700	472.2	83	84						
2150	597.2	69	78						

Parameter Chart

Model	Capacity		Head	Speed	Eff.	Motor power	NPSH	Impeller diameter	
	m³/h	L/S	m	r/min	%	kW	m	mm	
SBS 400-540E	1570	436.1	98.5	1450	76.5	800/90	8	540	
	2630	730.6	86		85				
	3420	950	70		79				
	1500	416.7	91		76	710/80			7.5
	2500	694.4	79.5		85				
	3250	902.8	64		79				
	1440	400	83		75	630			7
	2400	666.7	72		85				
	3120	866.7	57		79				
	1380	383.3	76		75	560			6.8
2305	640.3	64	84						
3000	833.3	50	79						
1330	369.4	69	75	500	6.5				
2210	613.9	58	83						
2880	800	44	78						
1320	366.7	77	76	500	6.6				
2200	611.1	63.5	86						
2860	794.4	48	79						
1260	350	69.5	76	450	6.5				
2100	583.3	57	85						
2730	758.3	41.5	78						
1200	333.3	53.6	76	355	6.2				
1990	552.8	49.5	83.5						
2500	694.4	37	77						
1110	308.3	54	75	315	6				
1850	513.9	43	83						
2340	650	33	76						

Dimensions

Model	Pump size ( mm )											WGT					
	m1	m2	m3	m4	n1	n2	n3	n4	b	a1	a2		l	f	h1	h2	H
350-620	650	560	900	810	435	495	385	445	120	740	670	720	910	775	460	1365	2120
400-540	840	720	1090	970	565	615	455	505	220	730	700	695	870	820	460	1420	2380

Connection dimensions

Model	Suction flange ( mm )					Discharge flange ( mm )					id&l of pump side coupling	Foudation bolts
	Ds	D1	D2	n-φd1	S1	Dd	D3	D4	n-φd2	S2		
350-620	400	525	580	16-φ30	43	350	470	520	16-φ28	41	φ95×170	4-M24×500
400-540	500	650	715	20-φ34	46	400	525	580	16-φ30	43	φ85×170	4-M36×600

SBS400-620 E Performance Curve n=1450r/min

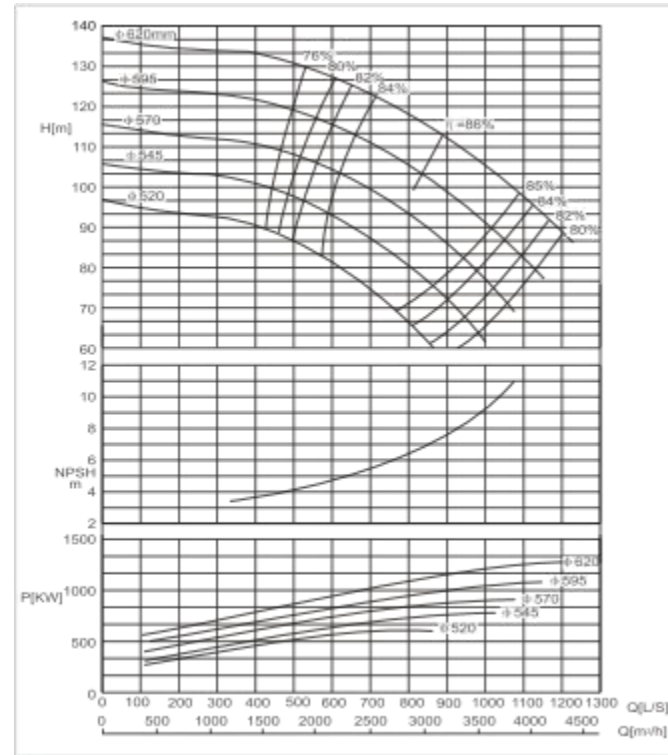

SBS400-620 F Performance Curve n=1450r/min

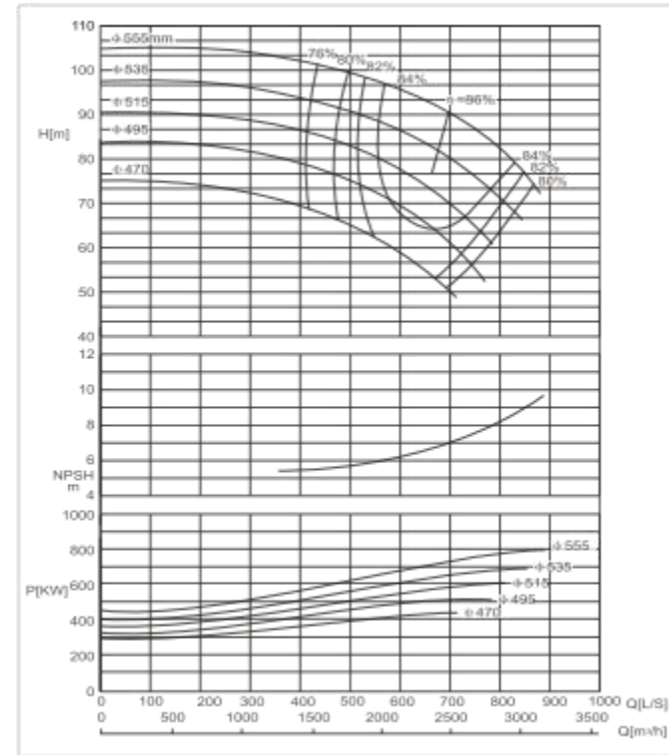

SBS500-510 E Performance Curve n=960r/min



SBS500-510 F Performance Curve n=960r/min

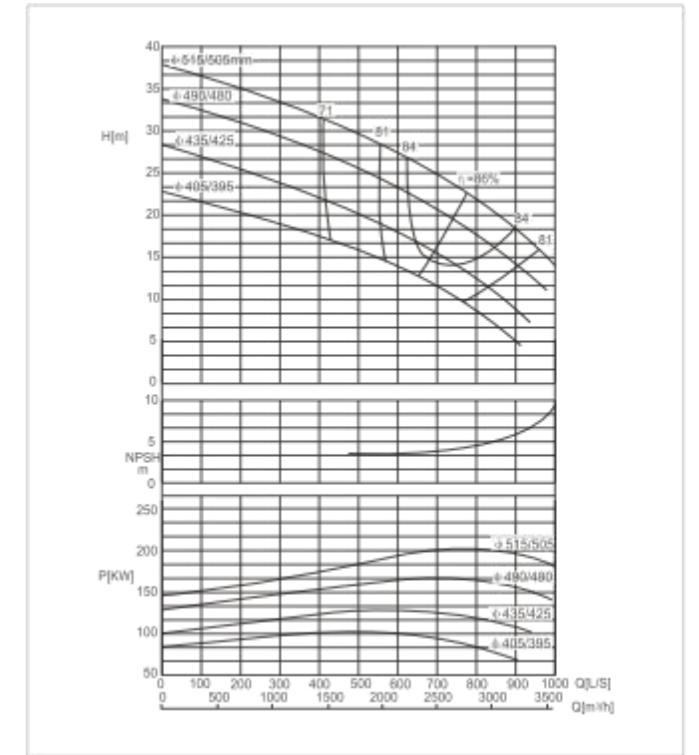

**SBS Horizontal pump installation dimension drawing**

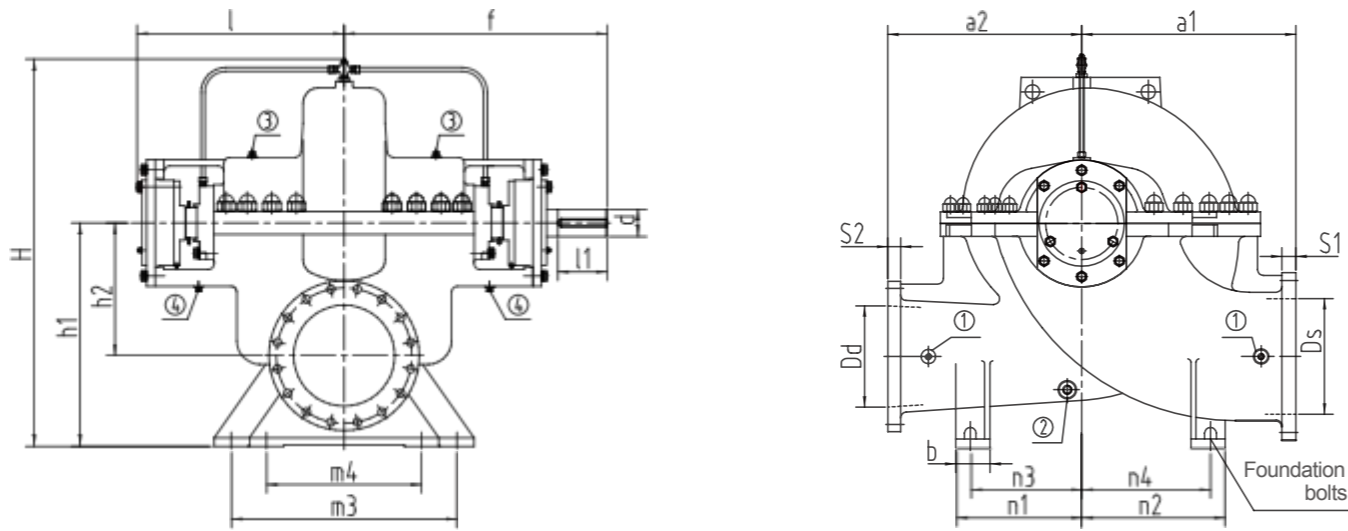

Suction flange Discharge flange

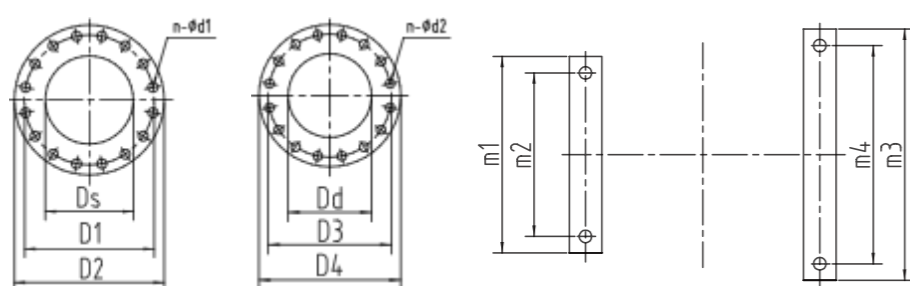

**Connection Dimensions**

- ① Pressure gauge Rp1/2
- ② Drain plug Rp1/2
- ③ Air vent Rp1/2
- ④ Leakage drains hole Rp3/4

**Parameter Chart**

Model	Capacity		Head m	Speed r/min	Eff. %	Motor power kW	NPSH m	Impeller diameter mm				
	m³/h	L/S										
SBS 400-620E	1890	525	129.5	1450	76	1250/1400	7.5	620				
	3150	875	113		86							
	4100	1139	93		83							
	1800	500	119		85.8	1120			6.7	570		
	3020	839	103		82							
	3920	1089	83		84							
	1740	483	109		77	800					6	545
	2995	804	92		85.5							
	3795	1044	87		80							
	1650	458	99		77	710						
2760	767	83	85.5									
3550	986	64	80									
1580	439	89	78	500	5	470						
2630	731	72	85.5									
3050	850	61.5	82									
SBS 400-620F	1500	417	101.5	1450			76	800	6.8	555		
	2485	690	90				86					
	3150	875	72				78					
	1440	400	94				76	710			6.5	535
	2310	667	82				85.8					
	2845	875	66				78					
	1440	400	79				75.8	630				
	2310	642	74.5		85.7							
	2845	790	60		78							
	1330	369	79.8		75	560	5.3	495				
2220	617	67.5	85									
2700	750	54	77									
1265	351	70.5	74	500	5	470						
2110	586	60	85									
2520	700	49.8	77									

**Parameter Chart**

Model	Capacity		Head m	Speed r/min	Eff. %	Motor power kW	NPSH m	Impeller diameter mm				
	m³/h	L/S										
SBS 500-510E	1945	540	33	960	73	280	5.5	530				
	3240	900	25		87							
	3925	1090	18		80							
	1855	515	31		72	250			4.5	510		
	3095	860	23		87							
	3800	1056	16.5		80							
1785	495	28.5	72	220	4	490						
2975	826.4	21	87									
3650	1014	14.3	79									
1680	466.7	23.2	72	200			4	470				
2800	778	18.5	87									
3420	950	13	78									
1600	444.4	24	70	160	3.6	445						
2670	742	16.5	86									
3150	815	12	77									
SBS 500-510F	1465	407	31.3	960			71	220	4.8	505		
	2775	771	22.5				86					
	3600	1000	14				79					
	1465	407	27.5		71	200	4	480				
	2638	732	19.5		86							
	3430	953	12		79							
	1505	418	21.8		71	160					4	425
	2450	681	15.8		85.5							
	3185	885	9.3		78							
	1365	379	17.5		69	132	4	395				
2280	633	13.2	84									
2965	824	8	77									

**Dimensions**

Model	Pump size ( mm )											WGT kg					
	m1	m2	m3	m4	n1	n2	n3	n4	b	a1	a2		l	f	h1	h2	H
400-620	840	720	1090	990	565	665	455	555	220	800	700	775	955	850	490	1455	2760
500-510	940	820	1240	1120	360	510	250	400	220	850	750	850	1025	900	475	1585	2304

**Connection dimensions**

Model	Suction flange ( mm )					Discharge flange ( mm )					id&l of pump side coupling	Foudation bolts
	Ds	D1	D2	n-φd1	S1	Dd	D3	D4	n-φd2	S2		
400-620	500	650	715	20-φ34	46	400	525	580	16-φ30	43	φ95×170	4-M42×600
500-510	600	770	840	20-φ37	55	500	650	715	20-φ34	46	φ75×140	4-M36×600

SBS500-640 E Performance Curve n=960r/min

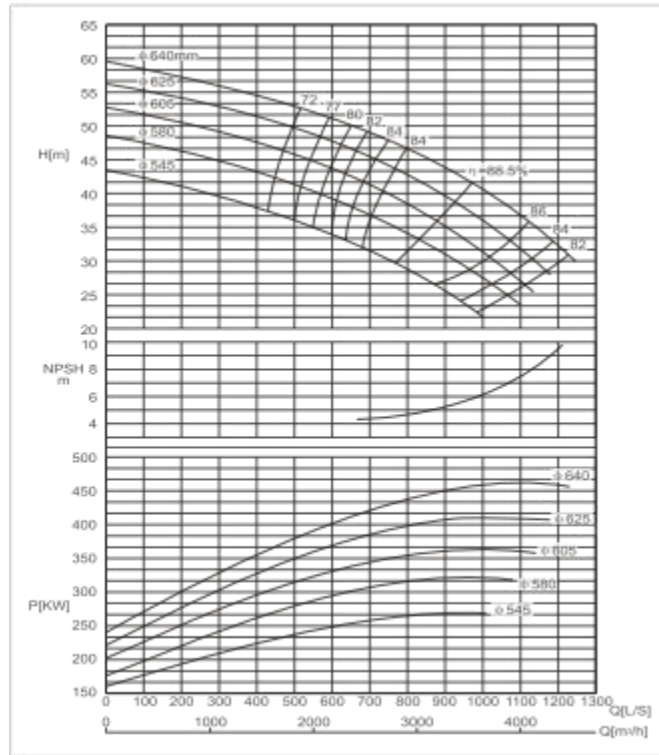

SBS500-640 F Performance Curve n=960r/min

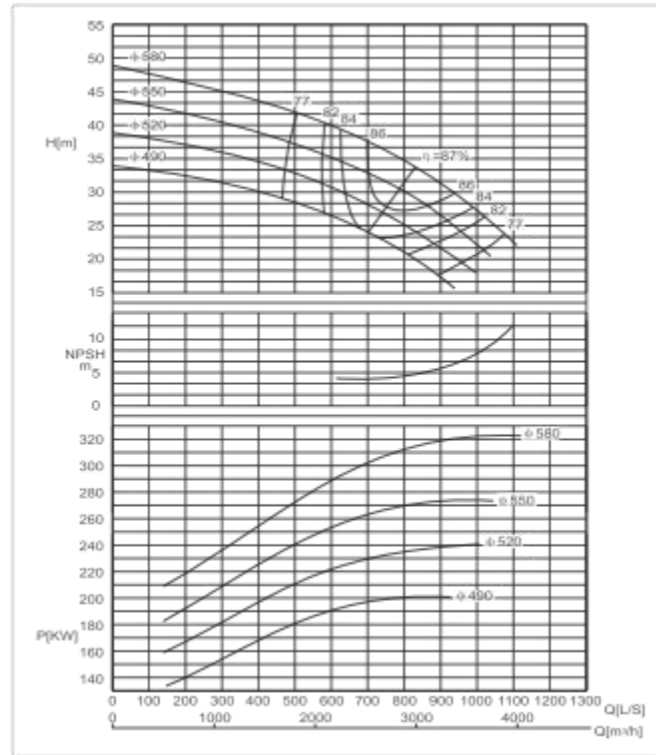

SBS500-700 E Performance Curve n=960r/min

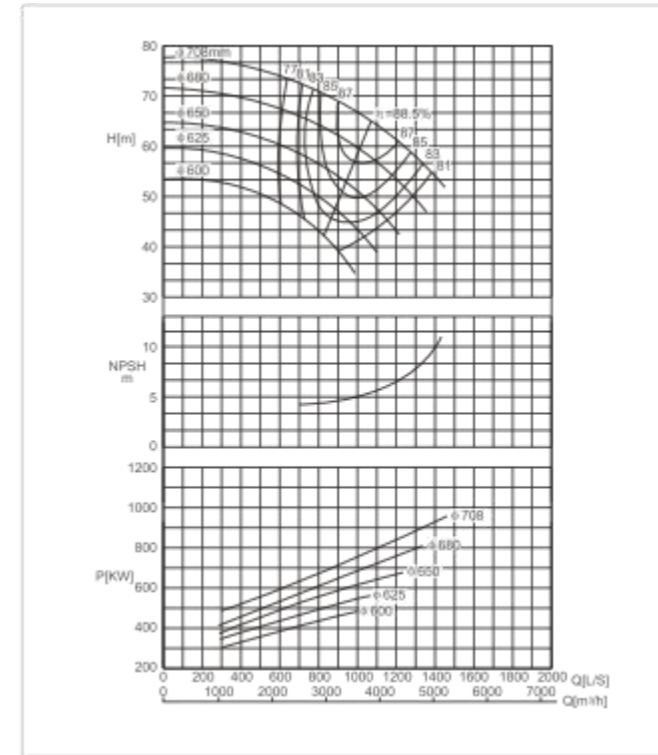

SBS500-700 F Performance Curve n=960r/min

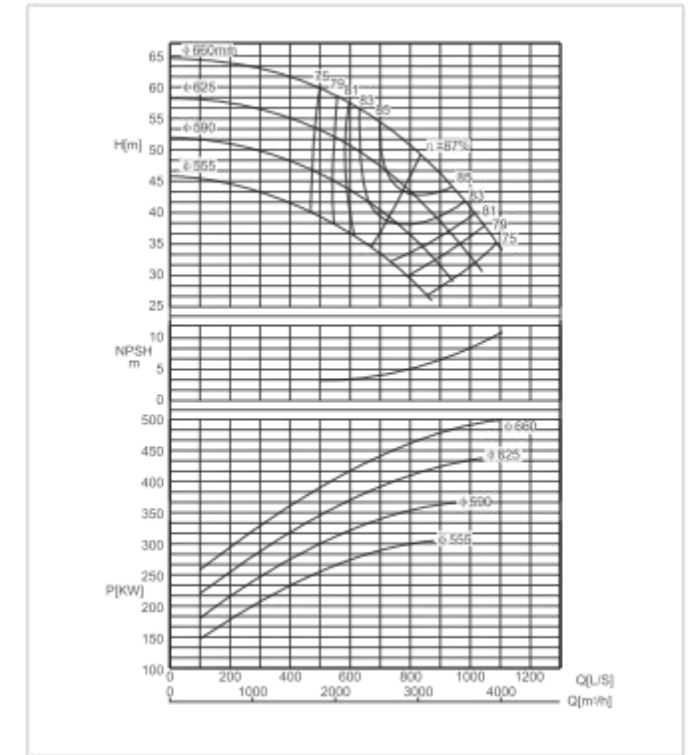

**SBS Horizontal pump installation dimension drawing**

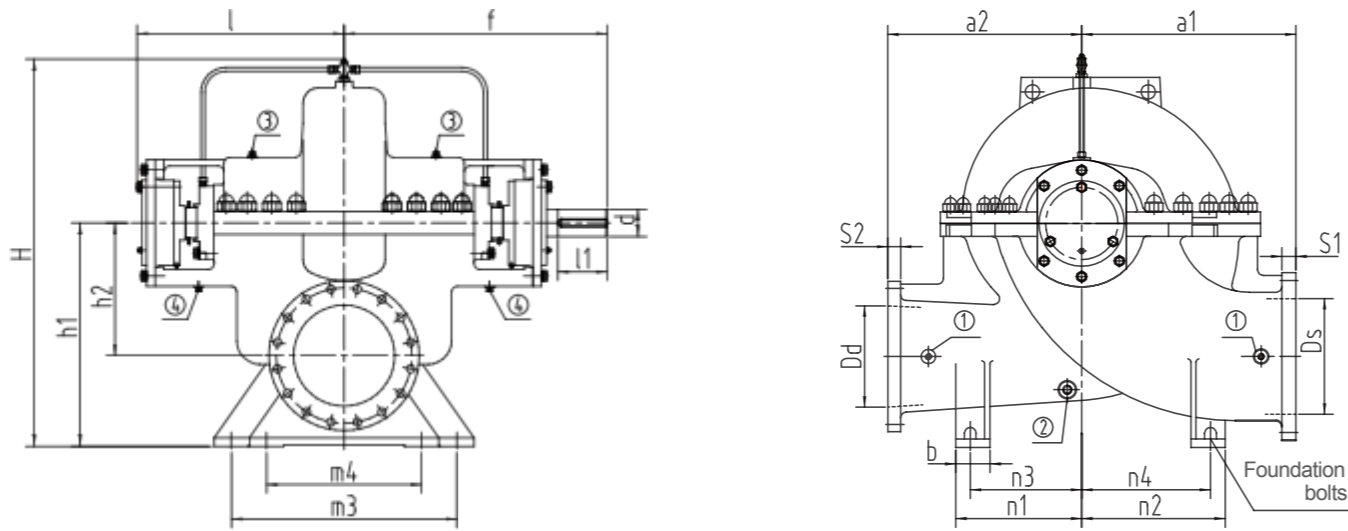

Suction flange Discharge flange

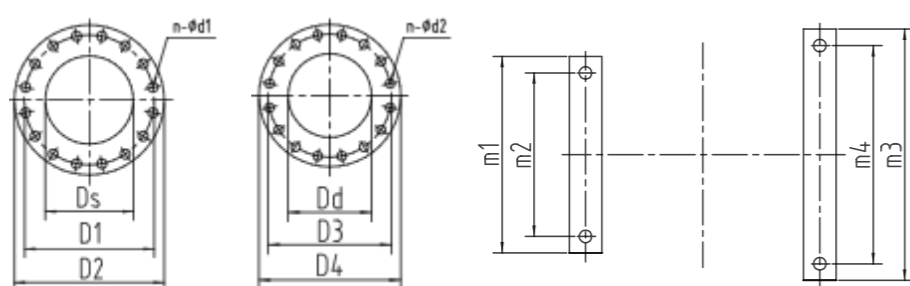

**Connection Dimensions**

- ① Pressure gauge Rp1/2
- ② Drain plug Rp1/2
- ③ Air vent Rp1/2
- ④ Leakage drains hole Rp3/4

**Parameter Chart**

Model	Capacity		Head m	Speed r/min	Eff. %	Motor power kW	NPSH m	Impeller diameter mm
	m³/h	L/S						
SBS 500-640E	1875	521	52.5	960	72	500	6	640
	3528	980	41.5		88.5			
	4500	1250	30		81			
	1800	500	50		72			
	3340	928	38.7		88			
	4210	1169	28.5		82			
	1710	475	46.5		72			
	3170	881	36		81			
	4030	1119	26.5		81			
	1620	450	42.5		72			
3020	839	33.2	87.5					
3830	1064	25	82					
1530	425	37.5	72					
2800	778	29.8	87					
3600	1000	22	80					
SBS 500-640F	1800	500	42	960	77	355	5	580
	2990	831	34		87			
	3885	1079	23		77			
	1700	472	38		76			
	2835	788	30.2		86			
	3685	1024	21		76			
	1640	456	33.8		75			
	2730	758	27.8		86			
	3510	975	18.5		75			
	1545	429	20.6		74.5			
2575	715	24	85					
3280	911	18	74.5					

**Parameter Chart**

Model	Capacity		Head m	Speed r/min	Eff. %	Motor power kW	NPSH m	Impeller diameter mm
	m³/h	L/S						
SBS 500-700E	2270	631	73	960	77	900/1000	6	708
	3850	1069	65		88.5			
	5040	1400	54		80			
	2200	611	67.5		77			
	3670	1019	59.5		88			
	4770	1325	48		79			
	2050	569	61		76			
	3420	950	53		87			
	4350	1208	42.5		78			
	1920	533	55.7		75			
3200	889	47.8	86					
3960	1100	39	77					
1810	503	50	74					
3020	839	42	85					
3560	989	35	76					
SBS 500-700F	1800	500	60	960	75	560	6	660
	3005	835	49		87			
	3905	1085	35		75			
	1680	467	53.5		74			
	2800	778	44.2		86			
	3640	1011	32.5		75			
	1600	444	47.5		73			
	2640	733	39.4		85			
	3360	933	29.2		74			
	1450	403	41.4		72			
2410	669	34.5	84					
3132	870	26.5	74					

**Dimensions**

Model	Pump size ( mm )											WGT kg					
	m1	m2	m3	m4	n1	n2	n3	n4	b	a1	a2		l	f	h1	h2	H
500-640	940	820	1240	1120	560	560	450	450	220	850	800	865	1115	920	495	1595	2301
500-700	965	945	1340	1220	660	760	550	650	220	1000	900	780	1140	1050	600	1710	2967

**Connection dimensions**

Model	Suction flange ( mm )					Discharge flange ( mm )					id&l of pump side coupling	Foudation bolts
	Ds	D1	D2	n-φd1	S1	Dd	D3	D4	n-φd2	S2		
500-640	600	770	840	20-φ37	55	500	650	715	20-φ34	46	φ95×170	4-M36×600
500-700	600	770	840	20-φ37	55	500	650	715	20-φ34	46	φ105×180	4-M36×600

SBS500-790 E Performance Curve n=960r/min

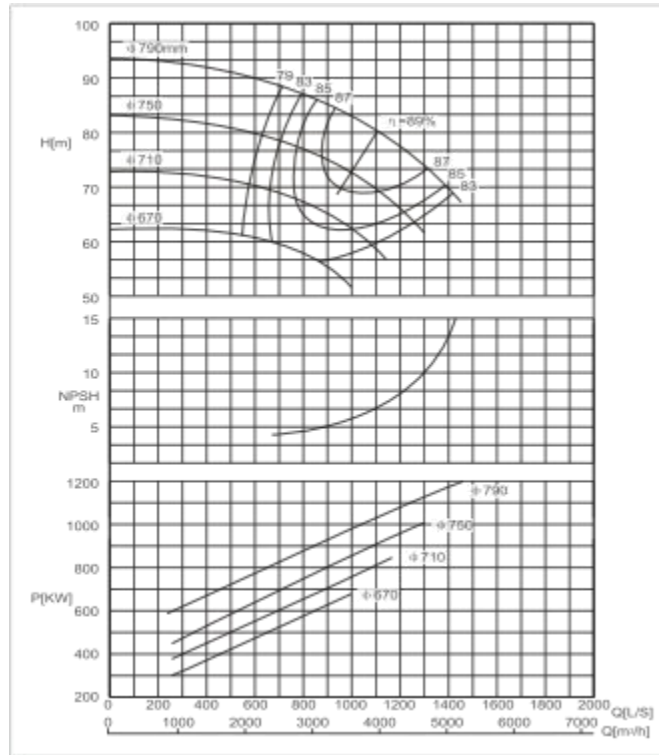

SBS500-790 F Performance Curve n=960r/min

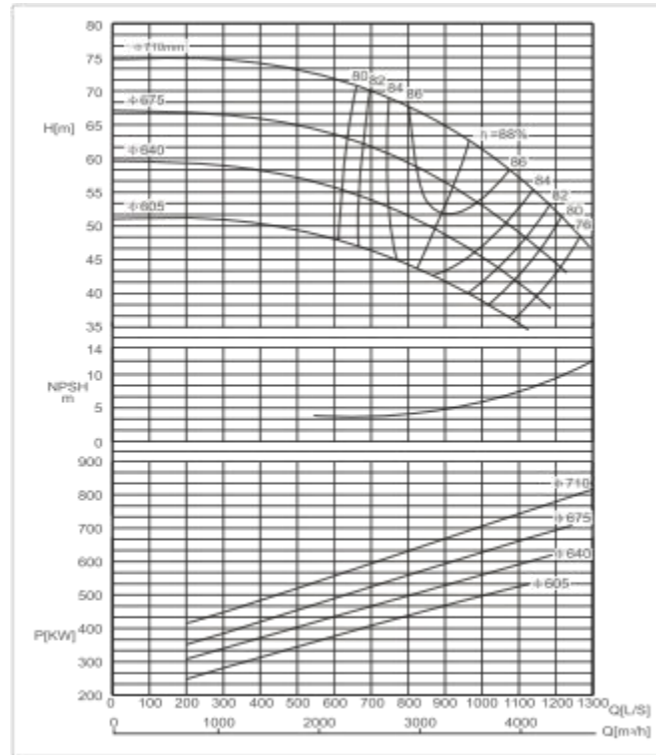

SBS500-890 E Performance Curve n=960r/min

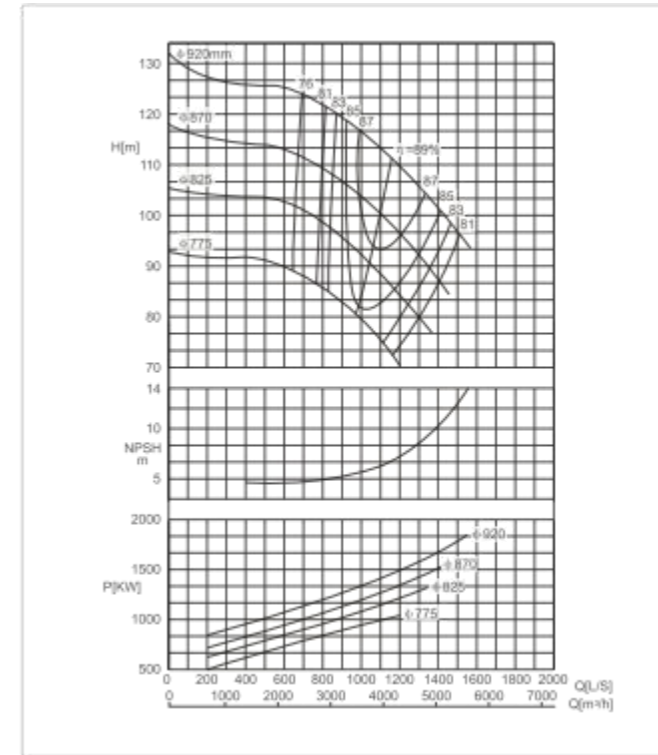

SBS500-890 F Performance Curve n=960r/min

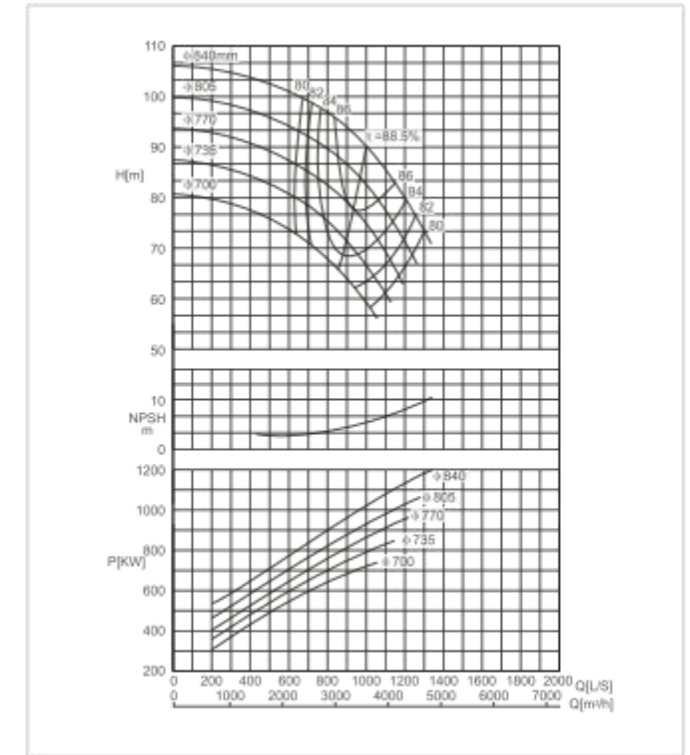

**SBS Horizontal pump installation dimension drawing**

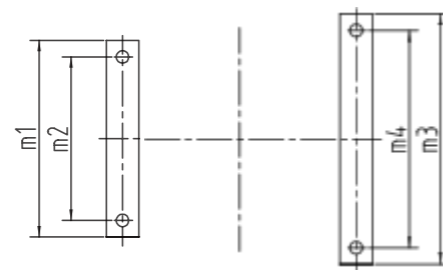
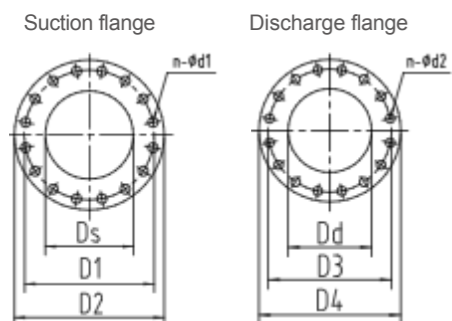
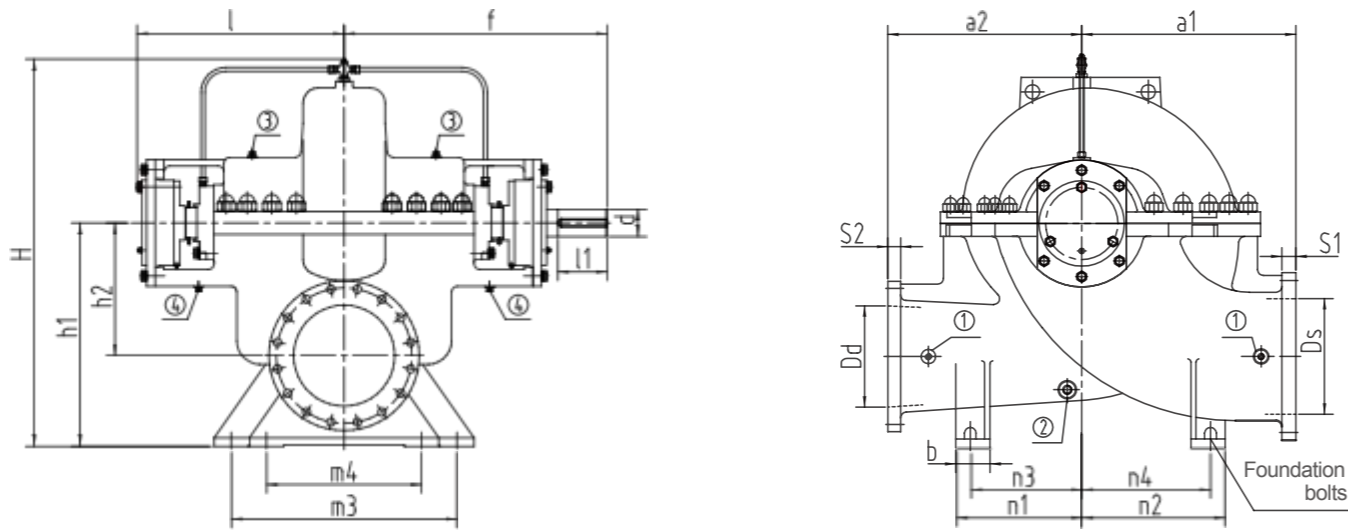

**Connection Dimensions**

- ① Pressure gauge Rp1/2
- ② Drain plug Rp1/2
- ③ Air vent Rp1/2
- ④ Leakage drains hole Rp3/4

**Parameter Chart**

Model	Capacity		Head m	Speed r/min	Eff. %	Motor power kW	NPSH m	Impeller diameter mm
	m³/h	L/S						
SBS 500-790E	2580	717	88.5	960	79	1120/1250	7.1	790
	3960	1100	80		89			
	5150	1431	68		82			
	2160	600	80		78	900/1120	6	750
	3600	1000	72.8		88			
	4680	1300	62		81			
	1930	536	71		77	800	5	710
	3220	894	65.5		87			
	4100	1139	57		80			
	1710	475	62		76	630/710	4.5	670
2850	792	58	86					
3600	1000	51.8	79					
SBS 500-790F	2375	660	70.8	960	80	800	5.8	710
	3492	970	62.5		88			
	4550	1264	48		75			
	2000	556	64		78	710	5	675
	3330	925	56		87			
	4350	1208	44		75			
	1900	528	57		77	560/630	4.5	640
	3150	875	50		86			
	4150	1153	39.3		74			
	1780	494	49		76	500/560	4	605
2970	825	43.6	85					
3900	1083	36	74					

**Parameter Chart**

Model	Capacity		Head m	Speed r/min	Eff. %	Motor power kW	NPSH m	Impeller diameter mm
	m³/h	L/S						
SBS 500-890E	2520	700	124	960	76	1600/1800	7	920
	4230	1175	112		89			
	5500	1528	95.5		80			
	2400	667	112		76	1400/1600	6	870
	4000	1111	100		88			
	5200	1444	86		79			
	2270	631	102.5		75	1250/1400	6	825
	3790	1053	90.5		87			
	4930	1369	77		78			
	2150	597	90		74	1120	5.5	775
3550	986	80.5	86					
4320	1200	70.5	77					
SBS 500-890F	2160	600	101	960	78	1120/1250	5.9	840
	3600	1000	90		88.5			
	4680	1300	73		80			
	2100	583	94.7		77	1000/1120	5	805
	3480	967	83.5		88			
	4520	1256	68		79			
	1920	558	88		76	900/1120	4.5	770
	3200	931	77.8		88			
	4020	1192	63		78			
	1920	533	82		75	800/900	4.2	735
3200	889	71.5	87					
4020	1117	60	77					
1840	511	75	74	800	4	700		
3060	850	66	86					
3780	1050	56	76					

**Dimensions**

Model	Pump size ( mm )											WGT kg					
	m1	m2	m3	m4	n1	n2	n3	n4	b	a1	a2		l	f	h1	h2	H
500-790	965	945	1340	1220	660	760	550	650	220	1000	900	780	1140	1050	600	1820	3483
500-890	1000	870	1240	1120	710	810	600	700	220	1050	950	920	1210	1100	650	1910	4659

**Connection dimensions**

Model	Suction flange ( mm )					Discharge flange ( mm )					id&l of pump side coupling	Foudation bolts
	Ds	D1	D2	n-φd1	S1	Dd	D3	D4	n-φd2	S2		
500-790	600	770	840	20-φ37	55	500	650	715	20-φ34	46	φ115×250	4-M36×600
500-890	600	770	840	20-φ37	55	500	650	715	20-φ34	46	φ135×250	4-M42×600

SBS600-540 E Performance Curve n=960r/min

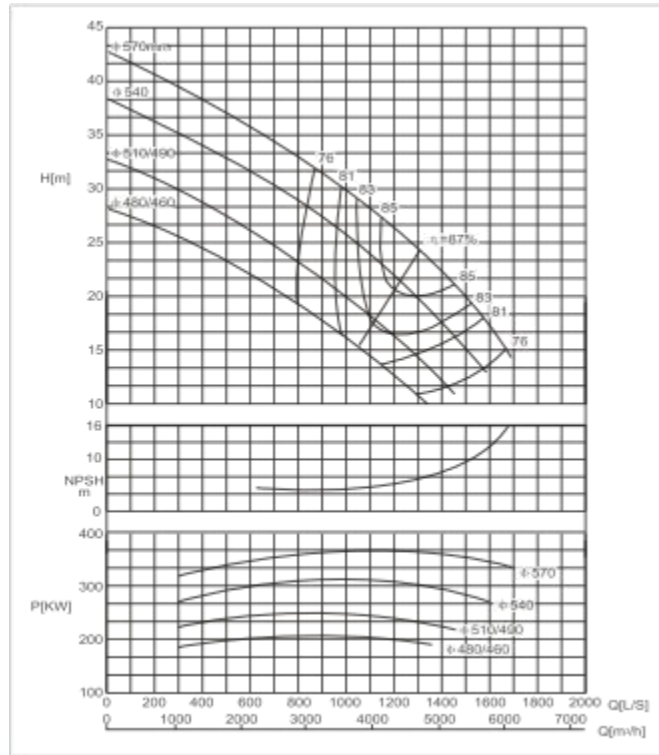

SBS600-540 F Performance Curve n=960r/min

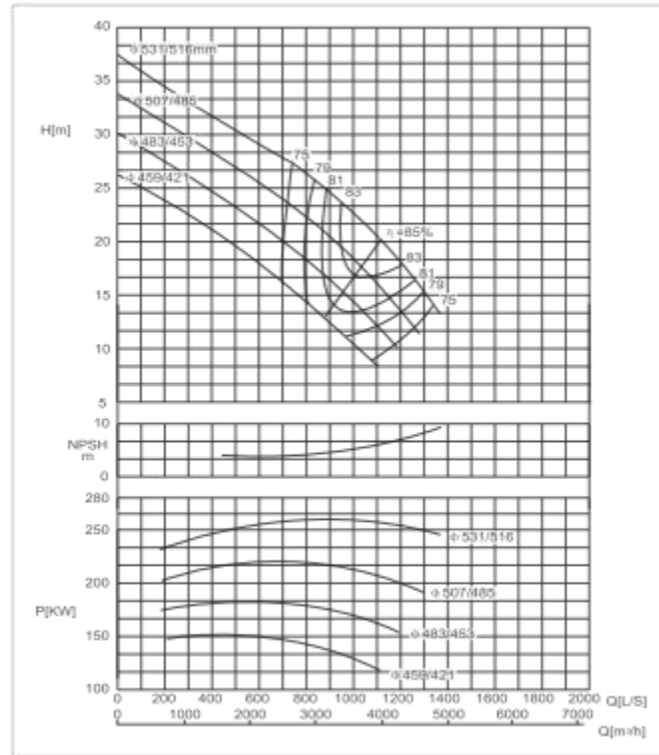

SBS600-620 E Performance Curve n=960r/min

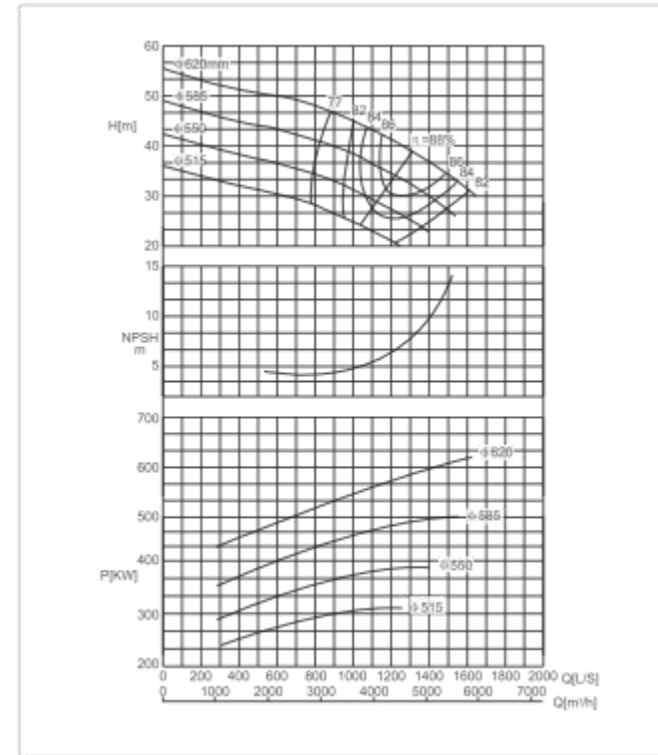

SBS600-620 F Performance Curve n=960r/min

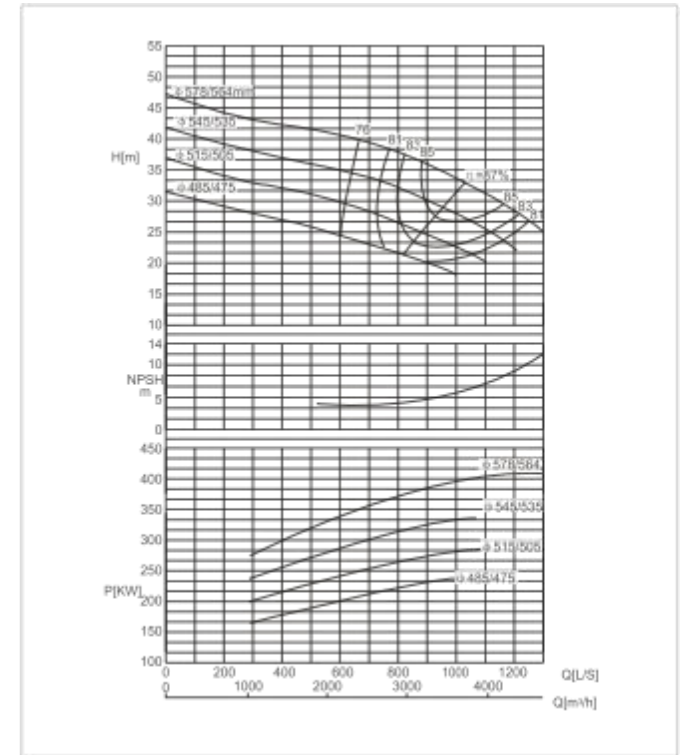

**SBS Horizontal pump installation dimension drawing**

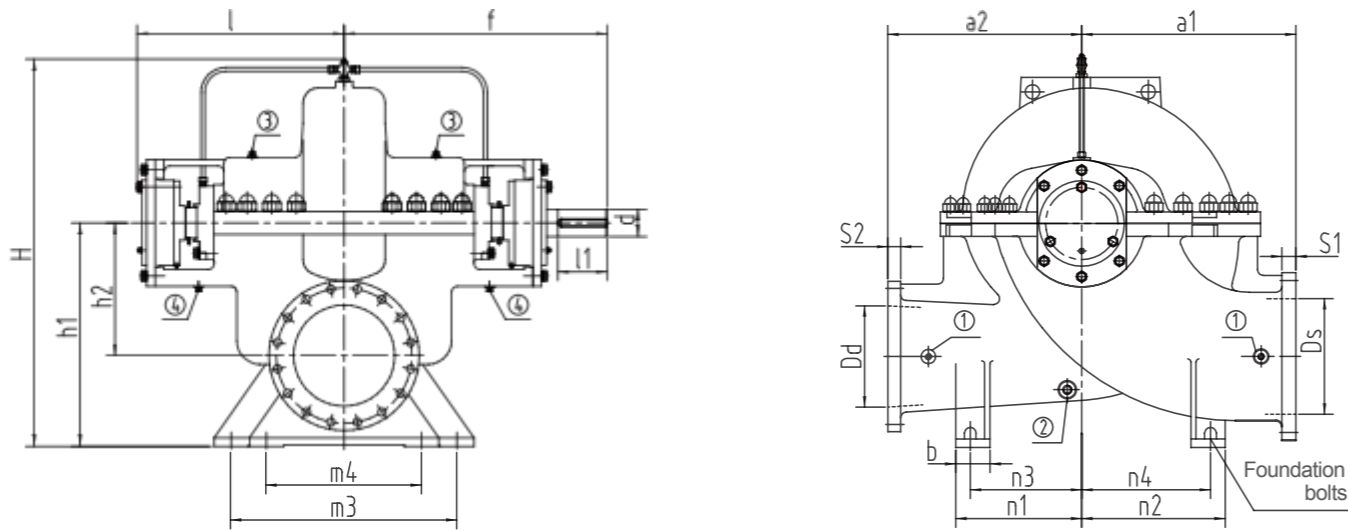

Suction flange

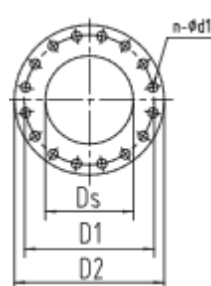

Discharge flange

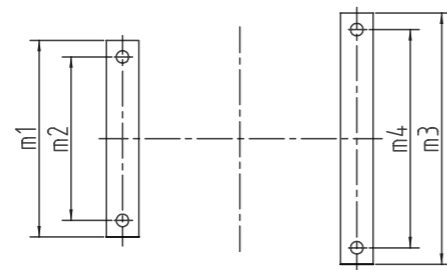
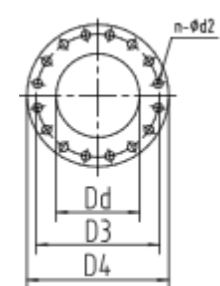

**Connection Dimensions**

- ① Pressure gauge Rp1/2
- ② Drain plug Rp1/2
- ③ Air vent Rp1/2
- ④ Leakage drains hole Rp3/4

**Parameter Chart**

Model	Capacity		Head m	Speed r/min	Eff. %	Motor power kW	NPSH m	Impeller diameter mm		
	m³/h	L/S								
SBS 600-540E	2810	781	33.3	960	74	400	5.9	570		
	4680	1300	24.2		87					
	6080	1689	14.3		75					
	2660	739	33.7		73	355			5	
	4430	1231	21.5		86					
	5690	1581	13		74					
	2430	675	25		72	250				4.5
	4040	1122	17.8		85					
	5220	1450	11		73					
	2270	631	21.5		71	220				
3780	1050	15.5	84							
4850	1347	10	72							
SBS 600-540F	2370	658	28.3	960	73	315	6	531		
	3960	1100	20.3		85					
	4900	1361	13.3		74					
	2250	625	28.8		72	250			5.8	
	3750	1042	18		84					
	4600	1278	11.5		73					
	2070	575	22.3		71	200				5
	3450	958	15.5		83					
	4250	1181	10		73					
	1890	525	19.3		70	160				
3150	875	13	82							
4000	1111	8.5	72							

**Parameter Chart**

Model	Capacity		Head m	Speed r/min	Eff. %	Motor power kW	NPSH m	Impeller diameter mm		
	m³/h	L/S								
SBS 600-620E	2830	786	48	960	75	630	7.8	620		
	4720	1311	39		88					
	5940	1650	30		81					
	2650	736	42		75	560			6.5	
	4420	1228	34		87					
	5580	1550	26		80					
	2450	681	36		74	450				6
	4080	1133	29		86					
	5040	1400	23.2		80					
	2250	625	30		73	355				
3750	1042	24.8	85							
4500	1250	20	79							
SBS 600-620F	2215	615	40.5	960	75	450	6	578		
	3690	1025	33		87					
	4680	1300	25		80					
	2060	572	35		74	355			5	
	3440	956	29		86					
	4400	1222	22		79					
	1900	528	30		73	280/315				4.7
	3170	881	25		85					
	3980	1106	20		78					
	1770	492	26		72	250				
2950	819	21.5	84							
3600	1000	18	77							

**Dimensions**

Model	Pump size ( mm )												WGT kg				
	m1	m2	m3	m4	n1	n2	n3	n4	b	a1	a2	l		f	h1	h2	H
600-540	950	800	1250	1100	700	800	550	650	300	1100	900	880	1020	1100	610	1850	2725
600-620	920	800	1220	1100	800	800	650	650	300	1000	1000	840	1060	1050	545	1900	2961

**Connection dimensions**

Model	Suction flange ( mm )					Discharge flange ( mm )					id&l of pump side coupling	Foundation bolts
	Ds	D1	D2	n-φd1	S1	Dd	D3	D4	n-φd2	S2		
600-540	700	840	910	24-φ37	55	600	770	840	20-φ37	55	φ80×170	4-M36×600
600-620	700	840	910	24-φ37	55	600	770	840	20-φ37	55	φ95×170	4-M36×600

SBS600-710 E Performance Curve n=960r/min

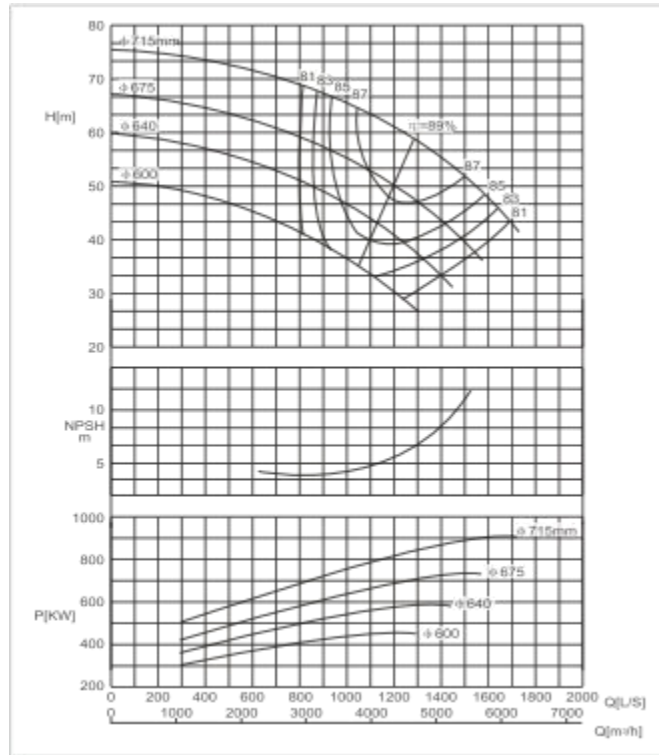

SBS600-710 F Performance Curve n=960r/min

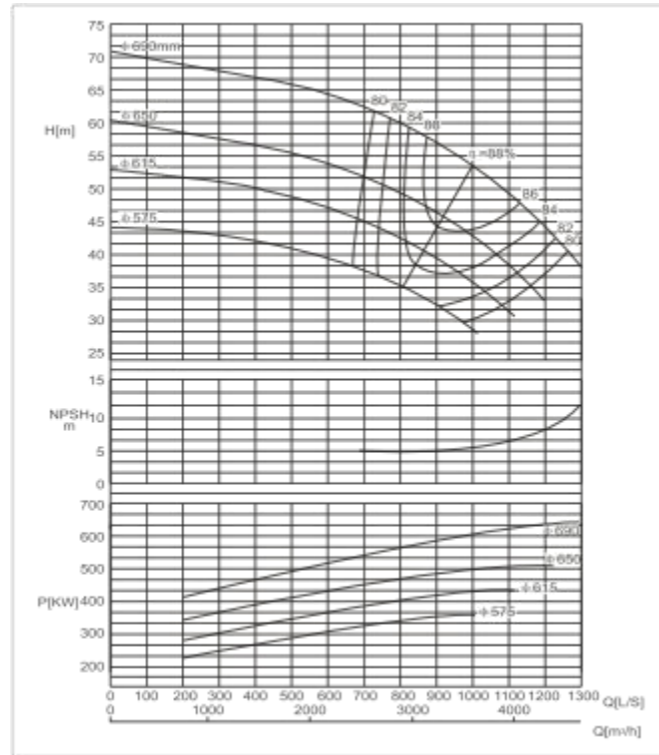

SBS600-830 E Performance Curve n=960r/min

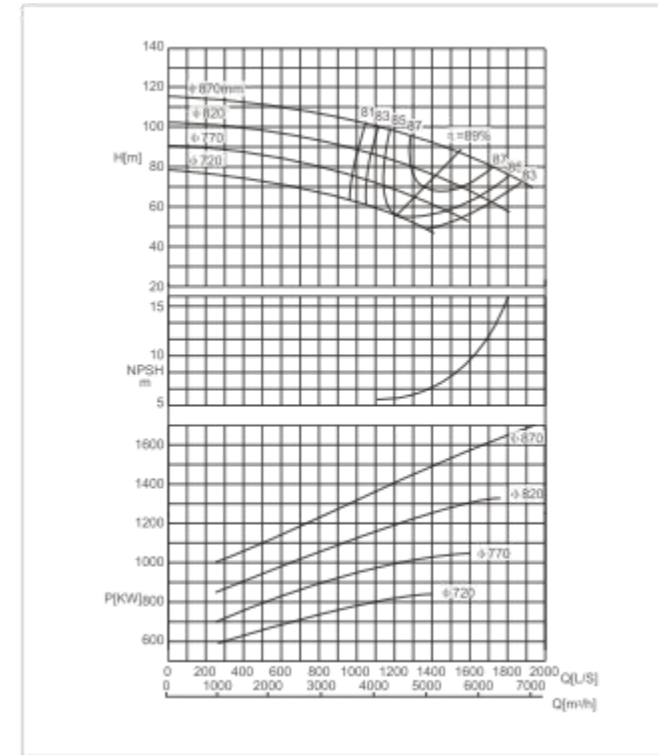

SBS600-830 F Performance Curve n=960r/min

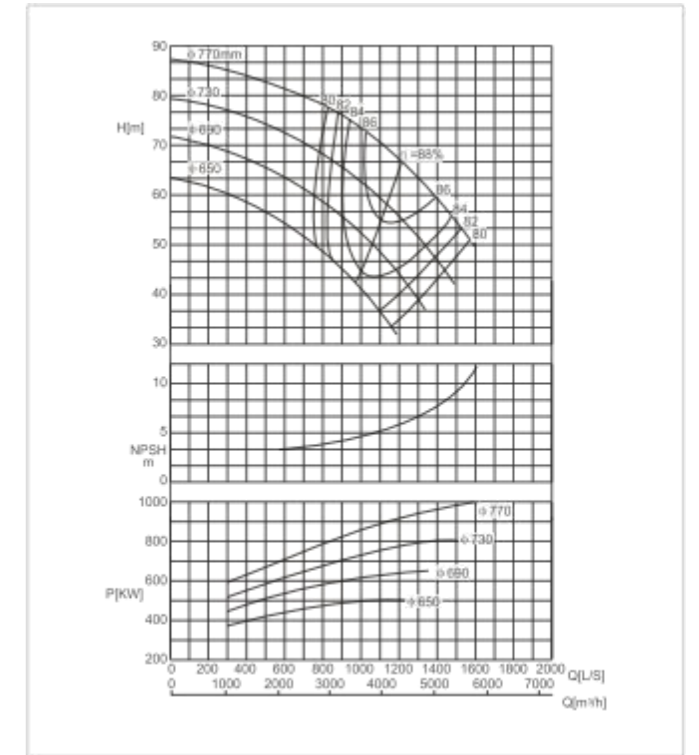

SBS Horizontal pump installation dimension drawing

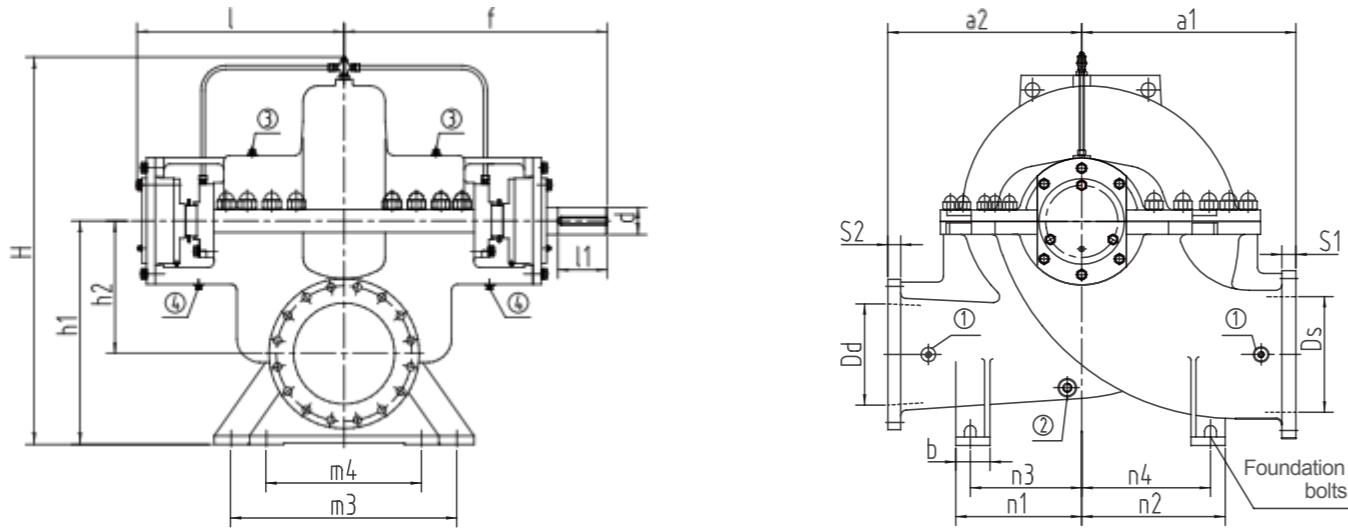

Suction flange

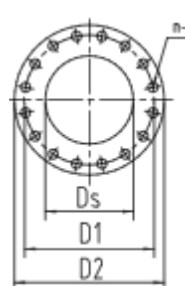

Discharge flange

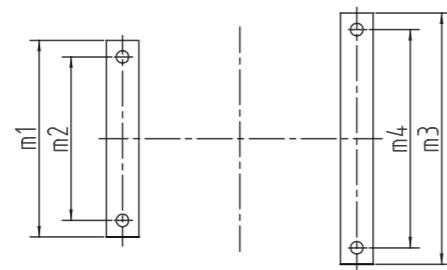
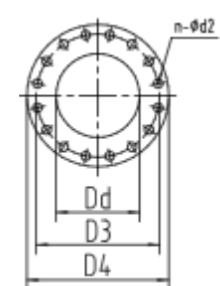

Connection Dimensions

- ① Pressure gauge Rp1/2
- ② Drain plug Rp1/2
- ③ Air vent Rp1/2
- ④ Leakage drains hole Rp3/4

Parameter Chart

Model	Capacity		Head m	Speed r/min	Eff. %	Motor power kW	NPSH m	Impeller diameter mm
	m <sup>3</sup> /h	L/S						
SBS 600-710E	2780	772	69	960	80	900	6.5	715
	4630	1286	58.5		89			
	6050	1680	43.5		80			
	2600	722	60.5		79	800	5.5	675
	4320	1200	50		88			
	5620	1561	36		79			
	2430	675	53		78	630	5	640
	4050	1125	43		87			
	5220	1450	31		78			
	2270	630	45		77	500	4.5	600
3780	1050	35	86					
4680	1300	27	77					
SBS 600-710F	2160	600	64.5	960	78	710	5.2	690
	3600	1000	54		88			
	4680	1300	38		78			
	1990	553	54.6		77	560	5	650
	3310	919	45.8		87			
	4300	1194	33		77			
	1880	522	48.2		76	450	5	615
	3130	869	40.5		86			
	4060	1128	30.5		76			
	1740	483	41		75	400	5	575
2900	806	35	85					
3670	1019	28	75					

Parameter Chart

Model	Capacity		Head m	Speed r/min	Eff. %	Motor power kW	NPSH m	Impeller diameter mm
	m <sup>3</sup> /h	L/S						
SBS 600-830E	3300	917	105	960	79	1600/1800	8.5	870
	5500	1528	87.5		89			
	6950	1931	70		82			
	3060	850	93		78	1400	7	826
	5110	1419	76		88			
	6480	1800	57		85			
	2800	778	82		77	1120/1400	6.2	770
	4680	1300	62		87			
	5800	1611	57		86			
	2610	725	70		76	900	5.8	720
4350	1208	56	87					
5040	1400	47	82					
SBS 600-830F	2600	722	79	960	78	1000	6	770
	4320	1200	66.2		88			
	5620	1561	51		80			
	2460	683	71.4		78	800	5.4	730
	4100	1139	58		87			
	5320	1478	42		79			
	2300	639	62.8		78	710/800	5	690
	3820	1061	50		87			
	4950	1375	48		83			
	2080	578	55		77	560	4.5	650
3460	961	42.5	86					
4250	1181	32	79					

Dimensions

Model	Pump size ( mm )												WGT kg				
	m1	m2	m3	m4	n1	n2	n3	n4	b	a1	a2	l		f	h1	h2	H
600-710	1020	900	1350	1200	800	800	650	650	300	1100	1000	930	1160	1050	545	1700	3427
600-830	1050	900	1350	1200	800	900	650	750	300	1100	1200	985	1260	1100	580	1950	4950

Connection dimensions

Model	Suction flange ( mm )					Discharge flange ( mm )					id&l of pump side coupling	Foudation bolts
	Ds	D1	D2	n-φd1	S1	Dd	D3	D4	n-φd2	S2		
600-710	700	840	910	24-φ37	55	600	770	840	20-φ37	55	φ115×250	4-M42×600
600-830	700	875	960	24-φ43	60	600	770	845	20-φ40	55	φ125×250	4-M42×600



SBS700-820 E Performance Curve n=960r/min

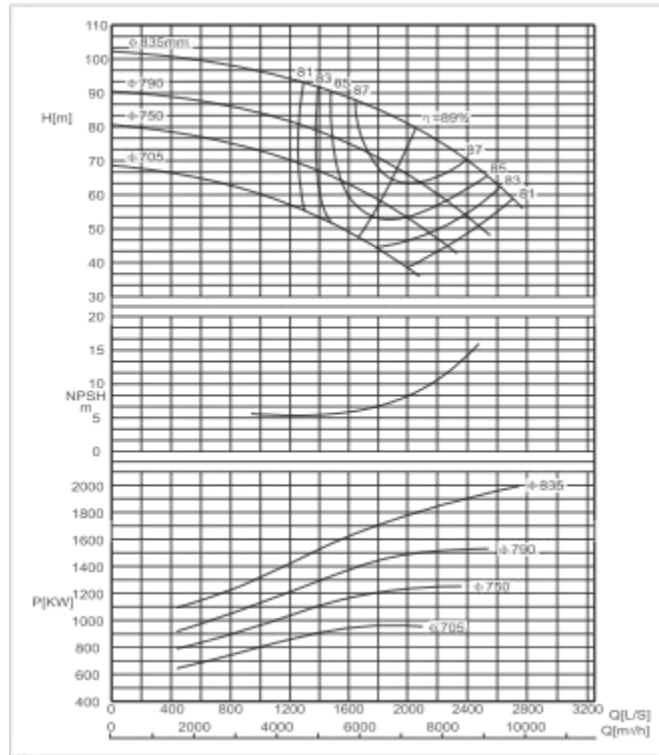

SBS700-820 F Performance Curve n=960r/min

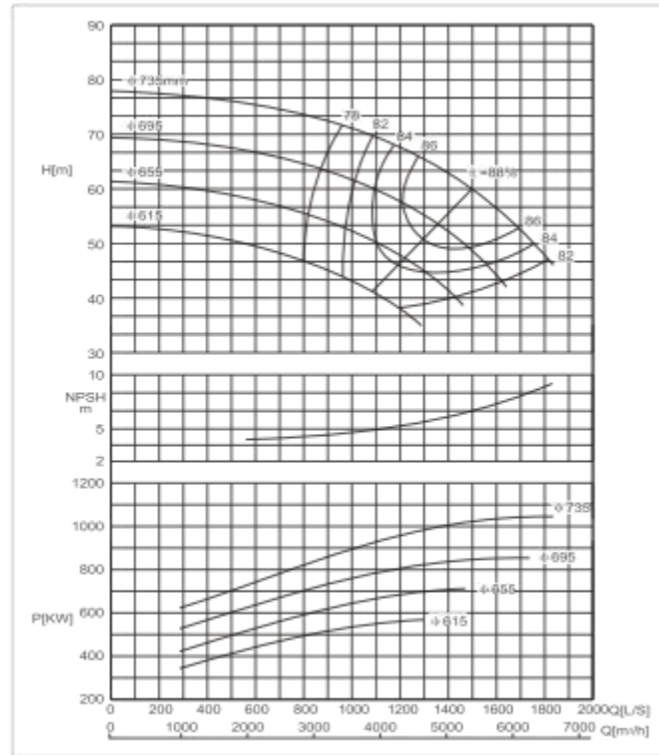

SBS800-740 E Performance Curve n=725r/min

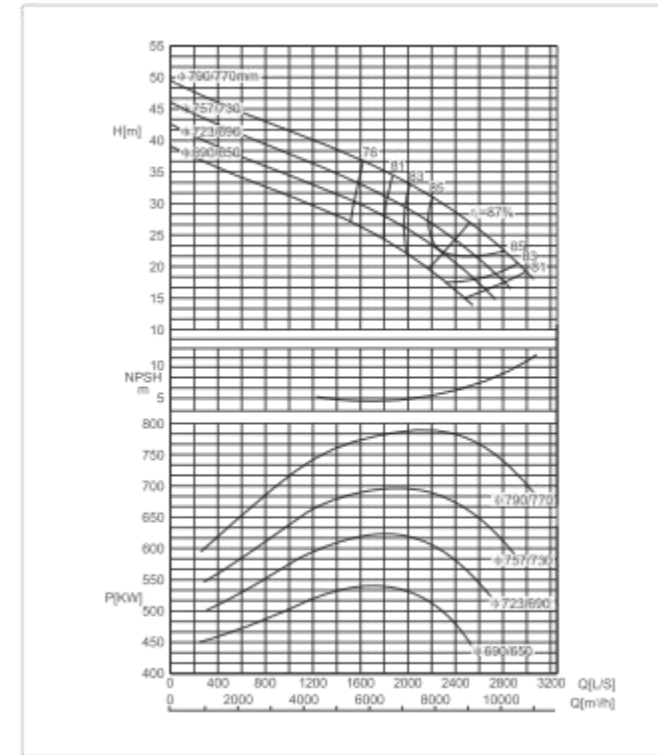

SBS800-740 F Performance Curve n=725r/min

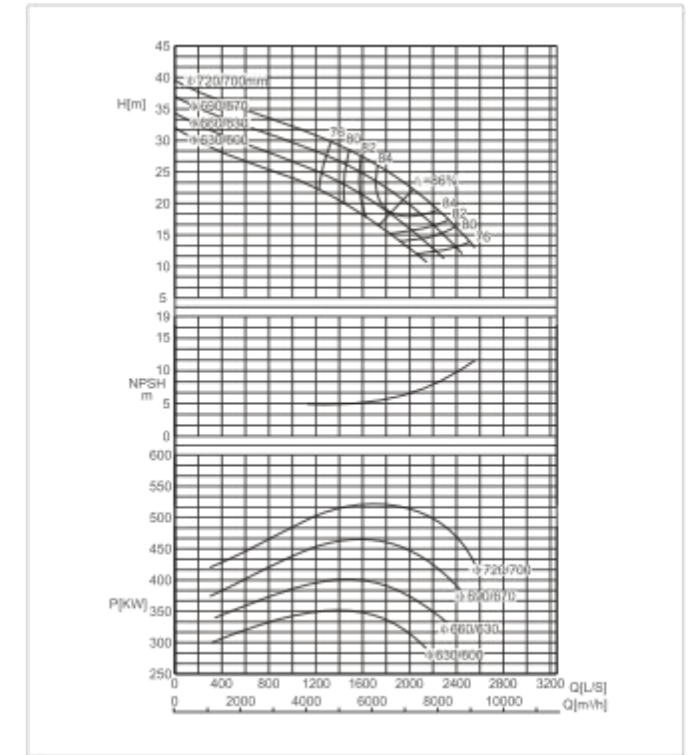

**SBS Horizontal pump installation dimension drawing**

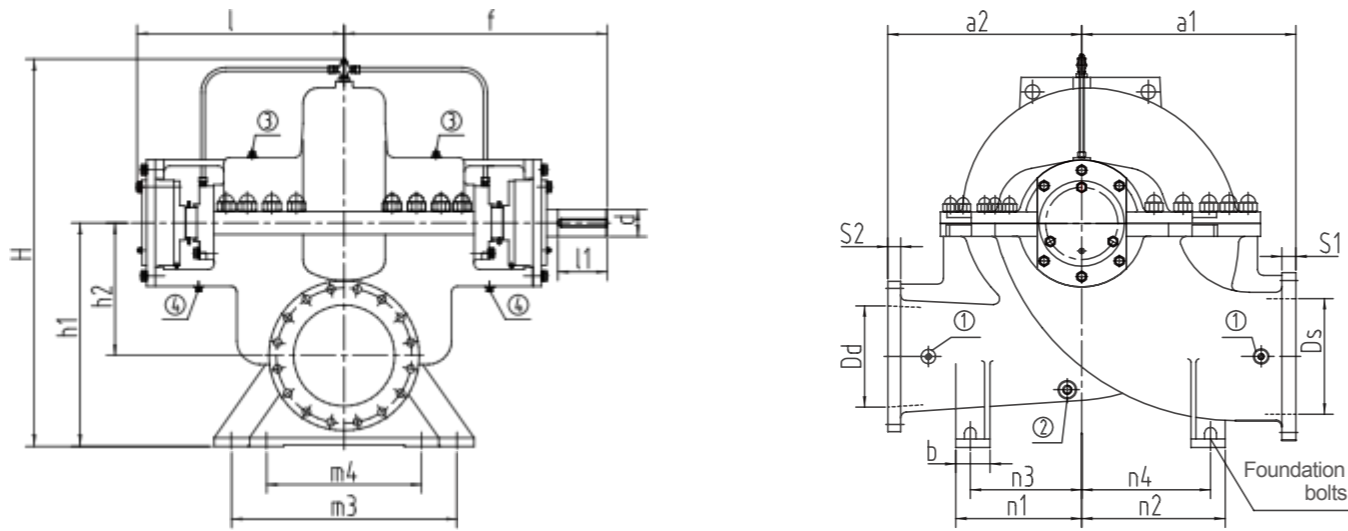

Suction flange Discharge flange

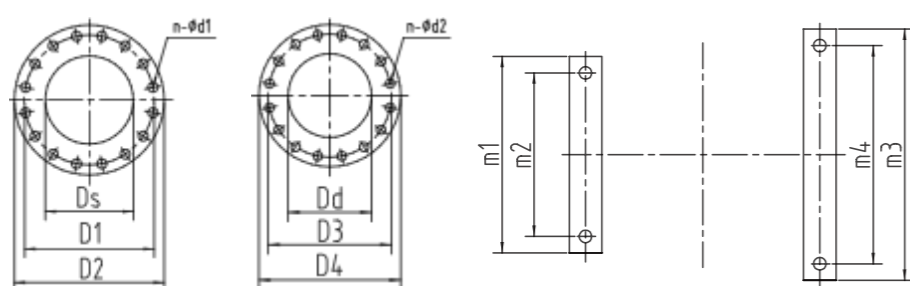

**Connection Dimensions**

- ① Pressure gauge Rp1/2
- ② Drain plug Rp1/2
- ③ Air vent Rp1/2
- ④ Leakage drains hole Rp3/4

**Parameter Chart**

Model	Capacity		Head m	Speed r/min	Eff. %	Motor power kW	NPSH m	Impeller diameter mm					
	m³/h	L/S											
SBS 700-820E	4430	1231	92	960	80	2000	8.8	835					
	7380	2050	80		89								
	9600	2667	60		82								
	4180	1161	82.6		80								
	6960	1933	68		88	1600			8	790			
	9050	2514	49		81								
	3930	1092	71.5		79	1400			7	750			
	6550	1819	58		87								
	8430	2342	43		80								
	3600	1000	60		78						1000	6.3	705
6010	1669	48	86										
7500	2083	36	79										
3240	900	72.8	77										
SBS 700-820F	5400	1500	60	960	88		1120	6.8			735		
	6600	1833	46		81								
	2970	825	65		77								
	4950	1375	53.8		87	900	6		695				
	5900	1639	42		80								
	2640	733	56.6		76	710	5.5		655				
	4400	1222	47		86								
	5260	1461	39		80								
	2340	650	49		75					630		5	615
	3900	1083	41.5		85								
4620	1283	35.5	79										

**Parameter Chart**

Model	Capacity		Head m	Speed r/min	Eff. %	Motor power kW	NPSH m	Impeller diameter mm					
	m³/h	L/S											
SBS 800-740E	5400	1500	37.8	725	74	800	7	790					
	9000	2500	27		87								
	11000	3056	18.2		80								
	5200	1444	34.5		74								
	8640	2400	24.3		86	710			6.3	757			
	10300	2861	16.5		79								
	4970	1381	31.6		74	1400			6	723			
	8280	2300	22.3		86								
	9850	2736	14.8		79								
	4700	1306	29		74						1000	5.5	690
7850	2180	20	86										
9200	2556	14	79										
4360	1211	30.8	75										
SBS 800-740F	7270	2019	22.2	725	86		560	7.2			720		
	9150	2542	13		75								
	4170	1158	28.6		75								
	6950	1931	20.6		85	500	7		690				
	8720	2422	12.5		75								
	3960	1100	26		74	450	6		660				
	6600	1833	18.5		84								
	8250	2292	11.4		74								
	3760	1044	23.8		73					400		6	630
	6260	1739	16.5		84								
7700	2139	10.5	74										

**Dimensions**

Model	Pump size ( mm )											WGT kg					
	m1	m2	m3	m4	n1	n2	n3	n4	b	a1	a2		l	f	h1	h2	H
700-820	940	790	1240	1090	950	950	775	775	350	1250	1250	970	1360	1200	650	2350	6075
800-740	1040	890	1340	1190	750	900	550	700	400	1400	950	1180	1410	1380	770	2400	6557

**Connection dimensions**

Model	Suction flange ( mm )					Discharge flange ( mm )					id&l of pump side coupling	Foudation bolts
	Ds	D1	D2	n-φd1	S1	Dd	D3	D4	n-φd2	S2		
700-820	800	950	1025	24-φ40	65	700	840	910	24-φ37	55	φ135×250	4-M42×600
800-740	900	1050	1125	28-φ40	68	800	950	1025	24-φ40	65	φ125×250	4-M42×600

SBS800-840 E Performance Curve n=725r/min

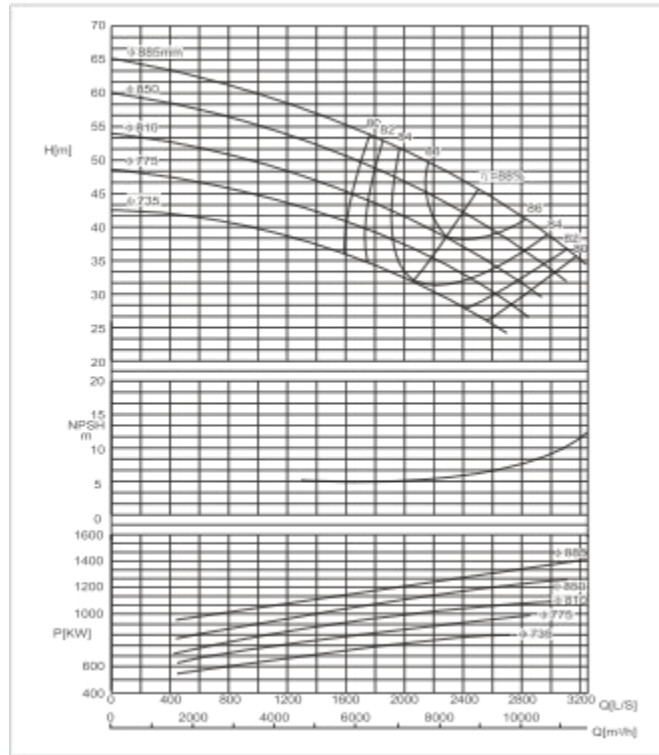

SBS800-840 F Performance Curve n=725r/min

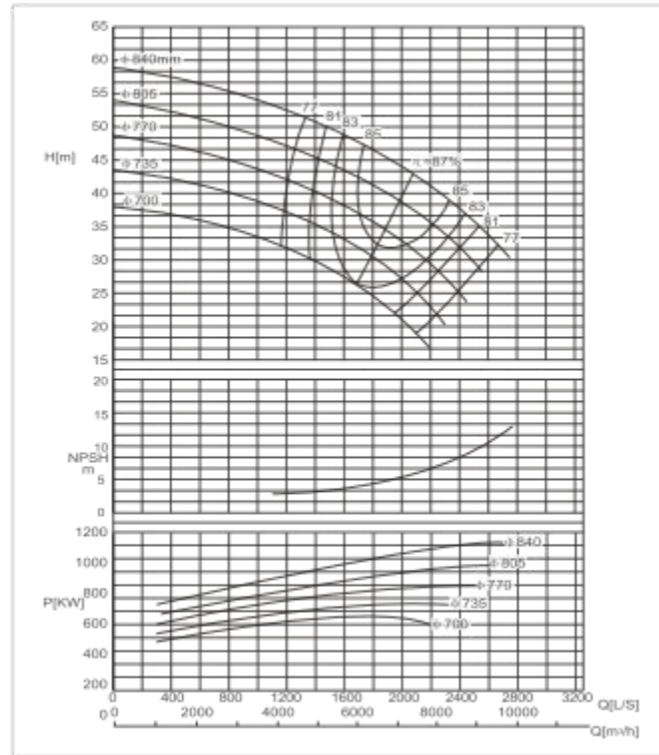

SBS800-970 E Performance Curve n=725r/min

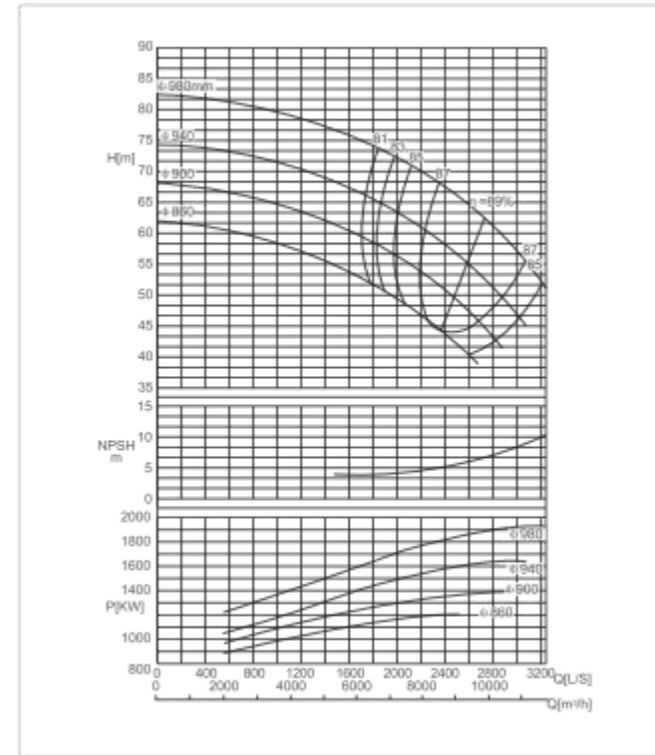

SBS800-970 F Performance Curve n=725r/min

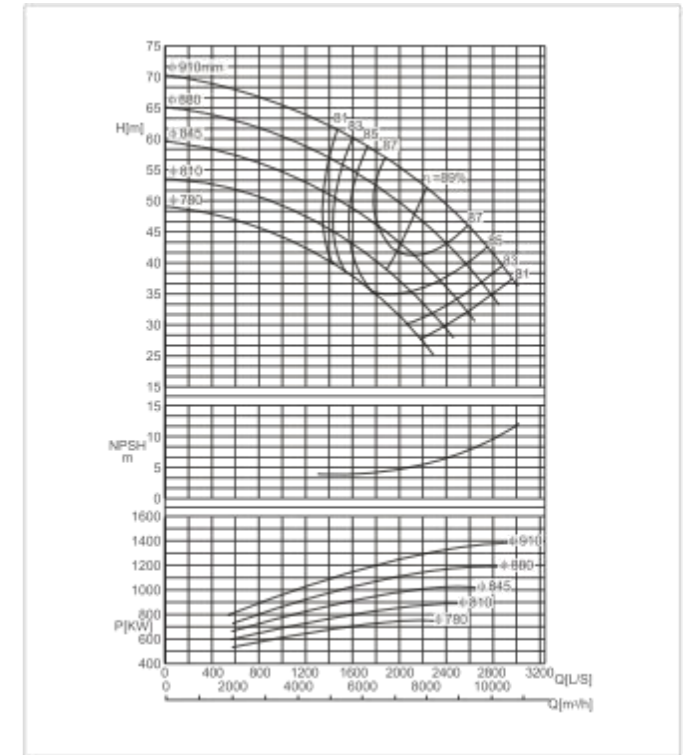

**SBS Horizontal pump installation dimension drawing**

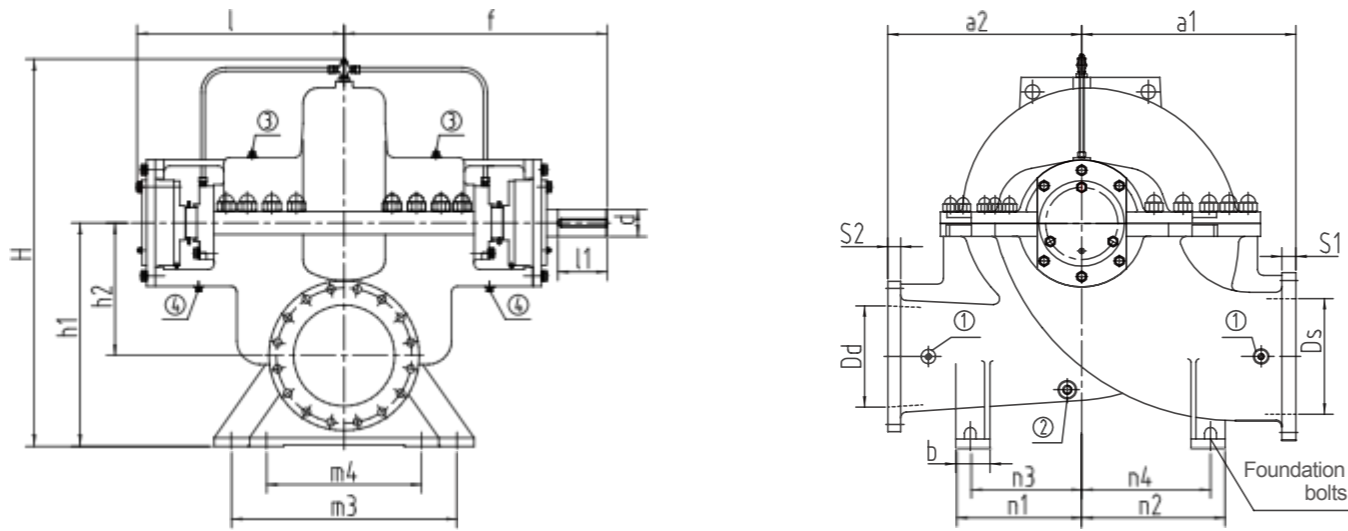

Suction flange Discharge flange

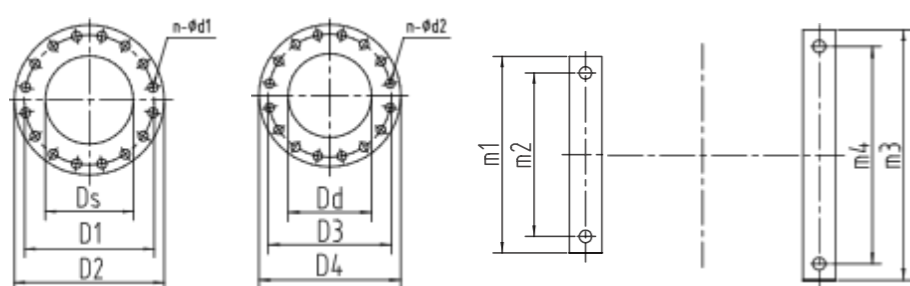

**Connection Dimensions**

- ① Pressure gauge Rp1/2
- ② Drain plug Rp1/2
- ③ Air vent Rp1/2
- ④ Leakage drains hole Rp3/4

**Parameter Chart**

Model	Capacity		Head m	Speed r/min	Eff. %	Motor power kW	NPSH m	Impeller diameter mm
	m³/h	L/S						
SBS 800-840E	5400	1500	56.4	725	78	1400	6.3	885
	9000	2500	46		88			
	11700	3250	34.5		79			
	5200	1444	52.2		78	1250	6	850
	8650	2403	42.3		87			
	11160	3100	32		79			
	4960	1378	47.5		77	1120	5.5	810
	8260	2204	38.5		96			
	10600	2944	30		79			
	4710	1308	43		76	1000	5.3	775
	7850	2181	35.4		86			
	10200	2833	26.8		78			
4470	1242	38.5	75	900	5	735		
7450	2069	32.2	85					
9700	2694	24.3	77					
SBS 800-840F	4500	1250	53	725	76	1120	6	840
	7500	2083	43		87			
	9750	2708	31.3		76			
	4300	1194	47.5		75	1000	5.2	805
	7150	1986	39		86			
	9180	2550	28		75			
	4080	1133	43		75	900	4.5	770
	6800	1889	34.8		95			
	8850	2458	23.8		75			
	3860	1072	38.5		74	710	4.2	735
	6430	1786	30.7		84			
	8280	2300	20		73			
3630	1008	33.5	73	630	4	700		
6050	1681	26.8	83					
7860	2183	16.8	74					

**Parameter Chart**

Model	Capacity		Head m	Speed r/min	Eff. %	Motor power kW	NPSH m	Impeller diameter mm
	m³/h	L/S						
SBS 800-970E	5880	1633	75.5	725	79	2000	7.1	980
	9800	2722	62.5		89			
	11600	3222	51.2		85			
	5580	1550	67.5		79	1800	6	940
	9300	2583	55		89			
	11000	3056	45.2		84			
5300	1472	61.5	79	1600	5.5	900		
8890	2469	49.5	88					
10400	2889	41.3	83					
5100	1417	55.5	78	1400	5	860		
8500	2361	44.5	87					
9650	2681	38	83					
SBS 800-970F	4800	1333	63	725	80	1400	6.8	910
	8000	2222	52		89			
	10450	2903	39		83			
	4600	1278	58.3		79	1250	5	880
	7650	2125	47.8		88			
	9950	2764	35.3		82			
	4350	1208	53.2		79	1250	5	845
	7240	2011	43.2		88			
	9500	2639	30.5		79			
	4100	1139	48		78	1000	4.5	810
	6840	1900	39		87			
	8820	2450	28		78			
3840	1067	44	77	800	4	780		
6400	1778	35	86					
8250	2292	25	77					

**Dimensions**

Model	Pump size ( mm )											WGT kg					
	m1	m2	m3	m4	n1	n2	n3	n4	b	a1	a2		l	f	h1	h2	H
800-840	1010	890	1310	1190	900	950	700	750	400	1400	1125	1180	1500	1360	770	2350	6624
800-970	1010	890	1310	1190	1000	1000	800	800	400	1400	1300	1270	1580	1370	760	2400	7809

**Connection dimensions**

Model	Suction flange ( mm )					Discharge flange ( mm )					id&l of pump side coupling	Foundation bolts
	Ds	D1	D2	n-φd1	S1	Dd	D3	D4	n-φd2	S2		
800-840	900	1050	1125	28-φ40	68	800	950	1025	24-φ40	65	φ125×250	4-M42×600
800-970	900	1050	1125	28-φ40	68	800	950	1025	24-φ40	65	φ145×250	4-M42×600

## Cummins Engine Series

NTA855-G4 Engine



KTA19-C675 Engine



QSK19-C650 Engine

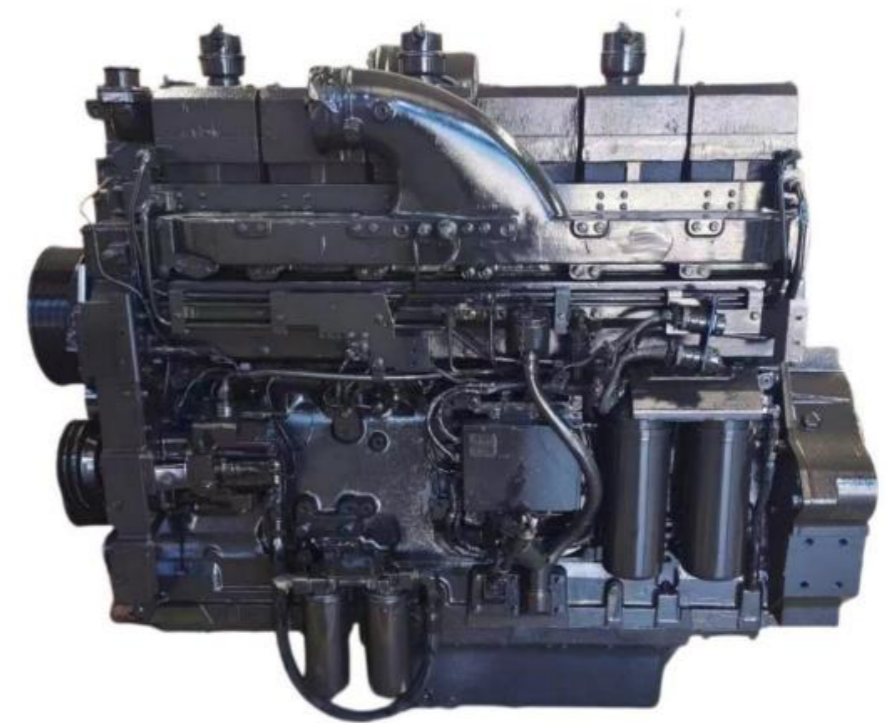

500KW DIESEL GENERATOR SET  
(KTAA19-G6)



1300KW Diesel Generator Set  
(KTA50-G9)

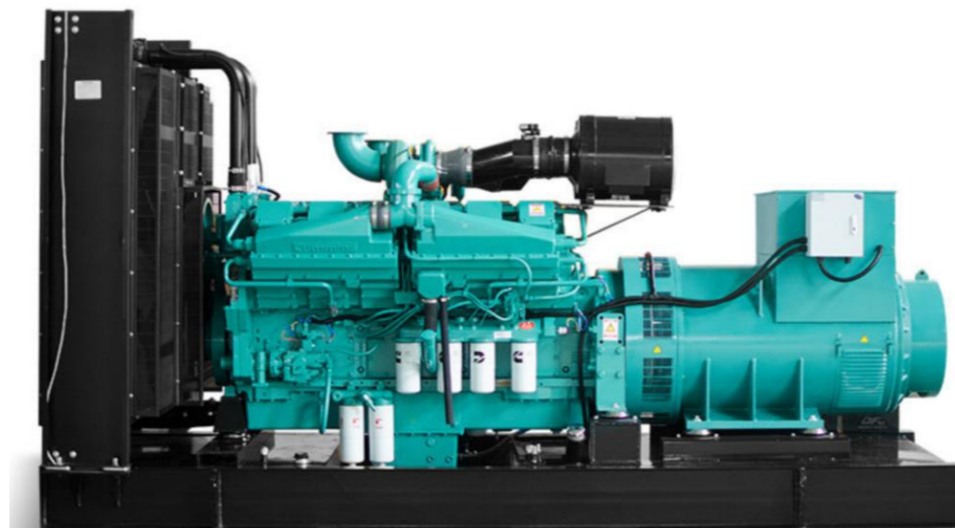

**หมายเหตุ**  
มีหลายรุ่นให้เลือก  
โดยหน้านี้แสดงเพียงบางรุ่นตัวอย่างเท่านั้น  
สำหรับรายละเอียดสเปกและข้อมูลทางเทคนิค  
สามารถแจ้งเพิ่มเติมตามความต้องการใช้งาน  
ได้

# Foam Tank

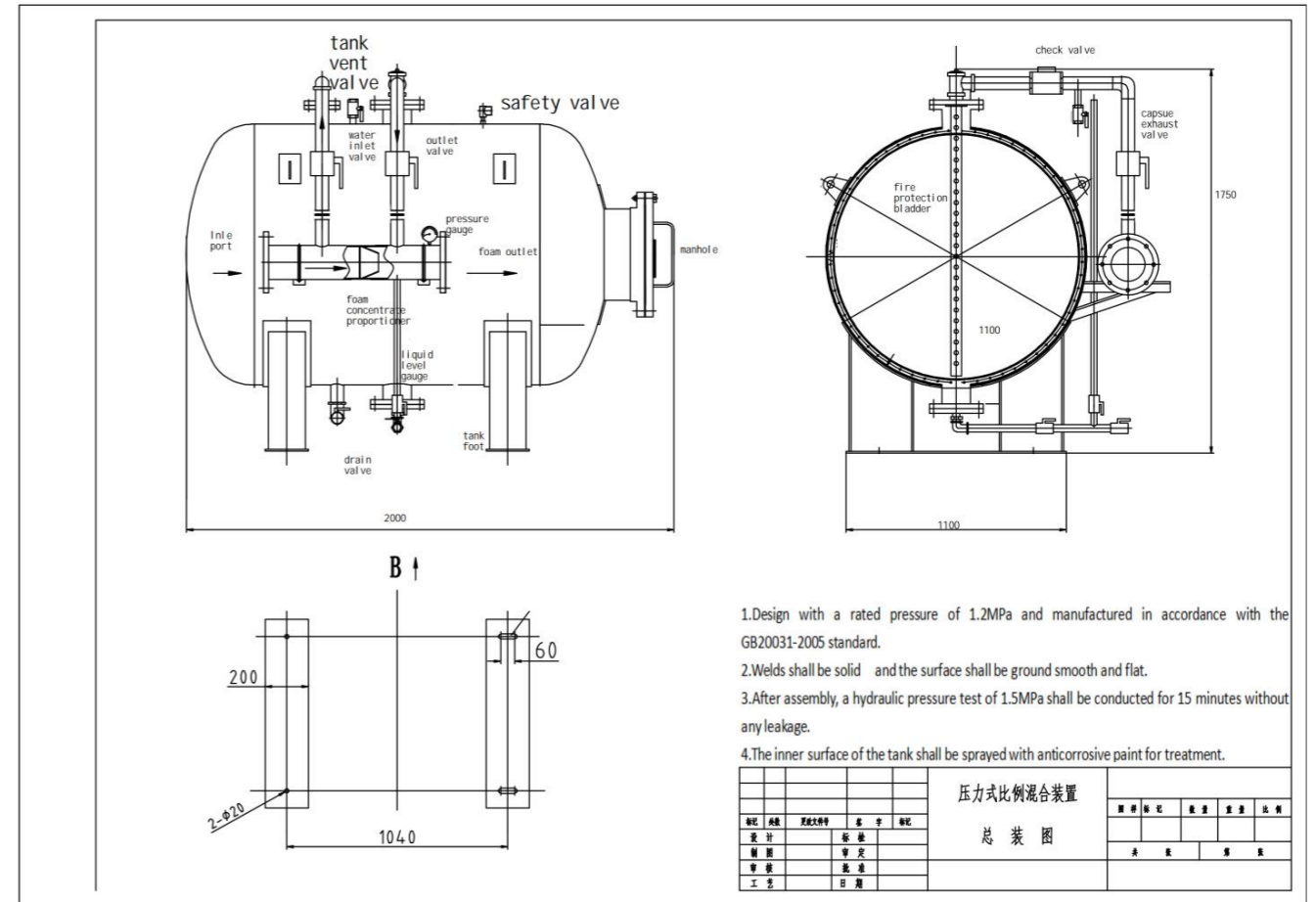

Horizontal Foam Tank

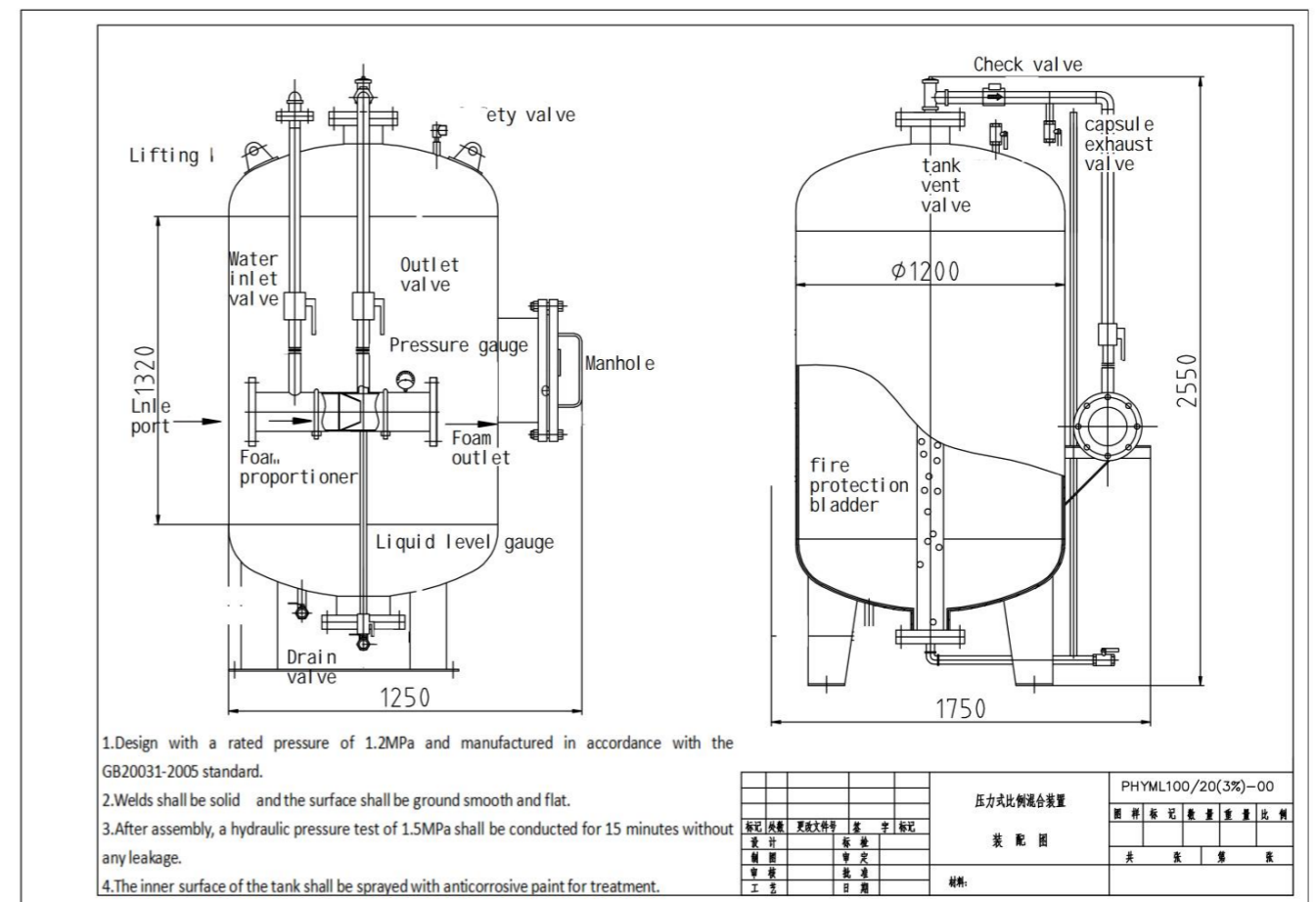

Vertical Foam Tank